

RADIO & ELECTRONICS CONSTRUCTOR

Vol. 26 No. 11

JUNE 1973

20p

SILICON - NETWORK POCKET PORTABLE

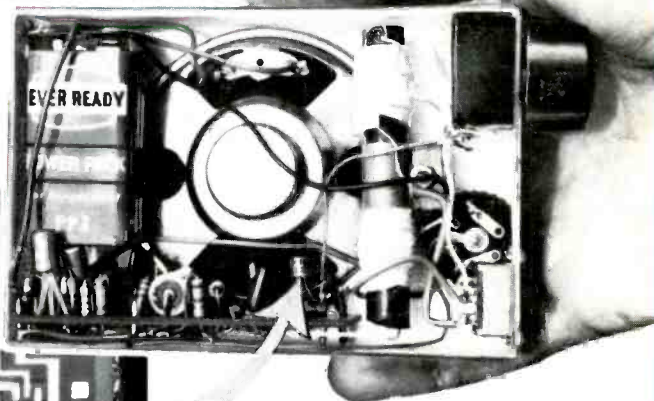
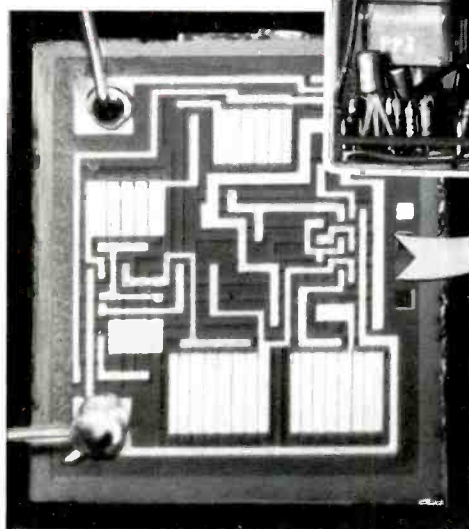

A MARVEL OF CHIP MINIATURISATION

The ZN414 silicon
network—chip area
enlarged 70 times

**ALSO
FEATURED**

**THE 'SLIDING JUNIOR'
AMPLIFIER**



Each £3 unit of Home Unit Insurance gives you protection up to the limit shown

This is the simplified insurance you have been waiting for. Not just cover on the contents of your home but a package of personal protection you and your family need. And it's how we save you so much money: just ONE policy to issue instead of nine! You can build up to the cover you need by additional units

(or ¼ units after the first) up to a maximum of five. So simple. So easy. Apply to your Broker, Agent or local office of a General Accident company. The Home Unit Policy can replace your existing insurances. And remember - as you buy more possessions just add more Home Units at any time. *Quote Ref. 20/9468*

THE GENERAL ACCIDENT FIRE & LIFE ASSURANCE CORPORATION LTD

Metropolitan House, 35 Victoria Avenue,
Southend-on-Sea, Essex, SS2 6BT

It pays to be protected by a **General Accident** company

Please send me further particulars of the Home Unit Insurance.

Name.....

Address.....

20/9468

THIS IS THE FIRST PAGE OF THE GREAT BI-PAK SECTION

BRAND NEW FULLY GUARANTEED DEVICES

AC 107	22p	AD 149	55p	BC 143	33p	BD 131	55p	BF 179	33p	C 444	38p	2G 301	2N 1613	22p	2N 2926(R)	11p	2N 3906	30p	
AC 113	22p	AD 161	36p	BC 145	49p	BD 132	66p	BF 180	33p	C 450	24p	2G 302	21p	2N 1889	35p	2N 2926(B)	11p	2N 4058	13p
AC 115	25p	AD 162	36p	BC 147	11p	BD 133	71p	BF 181	33p	MAT 100	21p	2G 303	21p	2N 1893	49p	2N 3011	15p	2N 4061	13p
AC 117K	22p	AD 161 and		BC 148	11p	BD 135	44p	BF 182	44p	MAT 101	22p	2G 304	26p	2N 2147	79p	2N 3054	50p	2N 4062	13p
AC 122	13p	ADT 140	60p	BC 149	13p	BD 136	44p	BF 183	44p	MAT 120	21p	2G 306	44p	2N 2148	62p	2N 3055	55p	2N 4284	18p
AC 126	18p	AF 114	26p	BC 150	20p	BD 137	49p	BF 184	27p	MAT 121	22p	2G 308	38p	2N 2160	66p	2N 3391	15p	2N 4285	18p
AC 127	18p	AF 115	26p	BC 152	18p	BD 138	55p	BF 185	33p	MFF 102	46p	2G 309	38p	2N 2192	38p	2N 3391A	15p	2N 4286	18p
AC 128	18p	AF 116	26p	BC 153	31p	BD 140	66p	BF 194	13p	MFF 104	40p	2G 319	22p	2N 2194	38p	2N 3395	15p	2N 4287	18p
AC 132	15p	AF 117	26p	BC 154	33p	BD 155	88p	BF 195	13p	OC 19	38p	2G 339A	11p	2N 2217	24p	2N 3394	15p	2N 4289	18p
AC 134	15p	AF 118	38p	BC 157	20p	BD 175	66p	BF 196	15p	OC 20	69p	2G 345	17p	2N 2218	22p	2N 3395	18p	2N 4290	18p
AC 137	15p	AF 124	33p	BC 158	13p	BD 176	66p	BF 197	15p	OC 22	42p	2G 371	17p	2N 2219	22p	2N 3402	23p	2N 4291	18p
AC 141	15p	AF 125	27p	BC 159	13p	BD 177	71p	BF 200	49p	OC 23	46p	2G 371B	13p	2N 2220	24p	2N 3403	23p	2N 4292	18p
AC 141K	18p	AF 126	31p	BC 160	49p	BD 178	71p	BF 222	1.04p	OC 24	61p	2G 373	18p	2N 2221	22p	2N 3404	31p	2N 4293	18p
AC 142	14p	AF 127	31p	BC 161	55p	BD 179	77p	BF 257	49p	OC 25	43p	2G 374	18p	2N 2222	22p	2N 3405	46p	2N 5172	13p
AC 142K	18p	AF 139	33p	BC 167	13p	BD 180	77p	BF 258	66p	OC 26	27p	2G 377	13p	2N 2268	18p	2N 3414	16p	2N 5457	35p
AC 151	18p	AF 178	55p	BC 168	13p	BD 185	71p	BF 259	93p	OC 28	55p	2G 378	17p	2N 2269	15p	2N 3415	16p	2N 5458	35p
AC 154	22p	AF 179	55p	BC 169	13p	BD 186	71p	BF 262	60p	OC 29	55p	2G 381	17p	2N 2369A	15p	2N 3416	31p	2N 5459	44p
AC 155	22p	AF 180	49p	BC 170	13p	BD 187	77p	BF 263	60p	OC 35	46p	2G 382	17p	2N 2412	26p	2N 3417	21p	2N 5501	55p
AC 156	22p	AF 181	49p	BC 171	15p	BD 188	77p	BF 270	38p	OC 36	55p	2G 401	33p	2N 2446	51p	2N 3525	82p	2N 5502	46p
AC 157	26p	AF 186	49p	BC 172	15p	BD 189	82p	BF 272	88p	OC 42	24p	2G 417	27p	2N 2711	23p	2N 3702	11p	2N 5503	46p
AC 165	22p	AL 209	71p	BC 173	15p	BD 190	82p	BF 270	88p	OC 42	24p	2G 417	27p	2N 2711	23p	2N 3702	11p	2N 5503	46p
AC 166	22p	AL 103	71p	BC 174	15p	BD 195	93p	BF 273	38p	OC 44	14p	2N 388A	38p	2N 2712	23p	2N 3703	11p	2N 5504	46p
AC 168	26p	ASV 26	27p	BC 175	24p	BD 196	93p	BF 274	38p	OC 45	14p	2N 388A	38p	2N 2714	23p	2N 3704	12p	2N 5505	92p
AC 169	15p	ASV 27	33p	BC 176	21p	BD 197	99p	BF 274	38p	OC 70	11p	2N 400A	22p	2N 2904	18p	2N 3705	11p	2N 5506	92p
AC 176	22p	ASV 28	27p	BC 179	21p	BD 199	99p	BF 279	33p	OC 71	11p	2N 400A	31p	2N 2904A	23p	2N 3706	10p	2N 5507	92p
AC 177	26p	ASV 29	27p	BC 180	24p	BD 200	1.04p	BF 285	55p	OC 72	15p	2N 424	46p	2N 2905	23p	2N 3707	12p	2N 5508	61p
AC 178	31p	ASV 30	27p	BC 181	26p	BD 205	88p	BF 286	55p	OC 74	15p	2N 424	54p	2N 2905A	23p	2N 3708	71p	2N 5509	66p
AC 179	31p	ASV 31	27p	BC 182	11p	BD 206	88p	BF 287	26p	OC 75	16p	2N 598	46p	2N 2906	16p	2N 3709	10p	2N 5522A	61p
AC 180	18p	ASV 32	27p	BC 183	11p	BD 207	88p	BF 288	26p	OC 76	16p	2N 599	49p	2N 2906A	20p	2N 3710	10p	2N 5523	61p
AC 180K	22p	ASV 34	27p	BC 184	11p	BD 208	1.04p	BF 288	26p	OC 77	27p	2N 696	14p	2N 2907	22p	2N 3711	10p	2N 5524	77p
AC 181	18p	ASV 35	27p	BC 183L	11p	BDY 20	1.10p	BF 290	22p	OC 81	16p	2N 697	14p	2N 2907A	24p	2N 3819	31p	2N 5525	77p
AC 181K	22p	ASV 36	27p	BC 184	13p	BF 117	49p	BF 52	22p	OC 82	16p	2N 698	26p	2N 2923	15p	2N 3820	38p	2N 5526	77p
AC 187	22p	ASV 38	27p	BC 186	31p	BF 118	77p	BF 53	18p	OC 82D	16p	2N 706	9p	2N 2925	15p	2N 3821	31p	2N 5527	77p
AC 187K	22p	ASZ 21	44p	BC 187	31p	BF 119	77p	BF 54	18p	OC 83	22p	2N 706A	10p	2N 2926(G)	14p	2N 3903	31p	40261	46p
AC 188	24p	ASZ 21	44p	BC 187	31p	BF 118	77p	BF 55	18p	OC 84	22p	2N 708	13p	2N 2926(Y)	12p	2N 3904	33p	40262	46p
AC 188K	22p	BC 107	10p	BC 207	10p	BF 123	55p	BSX 19	16p	OC 84	22p	2N 711	33p	2N 2926(O)	12p	2N 3905	31p	40263	49p
AC 189	22p	BC 108	10p	BC 208	12p	BF 125	55p	BSX 20	16p	OC 85	22p	2N 711	33p	2N 2926(O)	12p	2N 3905	31p	40263	49p
AC 192	22p	BC 109	11p	BC 209	12p	BF 127	55p	BSX 21	16p	OC 86	22p	2N 711	33p	2N 2926(O)	12p	2N 3905	31p	40263	49p
AC 193	22p	BC 110	11p	BC 210	12p	BF 127	55p	BSX 22	16p	OC 87	22p	2N 711	33p	2N 2926(O)	12p	2N 3905	31p	40263	49p
AC 194	22p	BC 111	11p	BC 211	12p	BF 127	55p	BSX 23	16p	OC 88	22p	2N 711	33p	2N 2926(O)	12p	2N 3905	31p	40263	49p
AC 195	22p	BC 112	11p	BC 212	12p	BF 127	55p	BSX 24	16p	OC 89	22p	2N 711	33p	2N 2926(O)	12p	2N 3905	31p	40263	49p
AC 196	22p	BC 113	11p	BC 213	12p	BF 127	55p	BSX 25	16p	OC 90	22p	2N 711	33p	2N 2926(O)	12p	2N 3905	31p	40263	49p
AC 197	22p	BC 114	11p	BC 214	12p	BF 127	55p	BSX 26	16p	OC 91	22p	2N 711	33p	2N 2926(O)	12p	2N 3905	31p	40263	49p
AC 198	22p	BC 115	11p	BC 215	12p	BF 127	55p	BSX 27	16p	OC 92	22p	2N 711	33p	2N 2926(O)	12p	2N 3905	31p	40263	49p
AC 199	22p	BC 116	11p	BC 216	12p	BF 127	55p	BSX 28	16p	OC 93	22p	2N 711	33p	2N 2926(O)	12p	2N 3905	31p	40263	49p
AC 200	22p	BC 117	11p	BC 217	12p	BF 127	55p	BSX 29	16p	OC 94	22p	2N 711	33p	2N 2926(O)	12p	2N 3905	31p	40263	49p
AC 201	22p	BC 118	11p	BC 218	12p	BF 127	55p	BSX 30	16p	OC 95	22p	2N 711	33p	2N 2926(O)	12p	2N 3905	31p	40263	49p
AC 202	22p	BC 119	11p	BC 219	12p	BF 127	55p	BSX 31	16p	OC 96	22p	2N 711	33p	2N 2926(O)	12p	2N 3905	31p	40263	49p
AC 203	22p	BC 120	11p	BC 220	12p	BF 127	55p	BSX 32	16p	OC 97	22p	2N 711	33p	2N 2926(O)	12p	2N 3905	31p	40263	49p
AC 204	22p	BC 121	11p	BC 221	12p	BF 127	55p	BSX 33	16p	OC 98	22p	2N 711	33p	2N 2926(O)	12p	2N 3905	31p	40263	49p
AC 205	22p	BC 122	11p	BC 222	12p	BF 127	55p	BSX 34	16p	OC 99	22p	2N 711	33p	2N 2926(O)	12p	2N 3905	31p	40263	49p
AC 206	22p	BC 123	11p	BC 223	12p	BF 127	55p	BSX 35	16p	OC 100	22p	2N 711	33p	2N 2926(O)	12p	2N 3905	31p	40263	49p
AC 207	22p	BC 124	11p	BC 224	12p	BF 127	55p	BSX 36	16p	OC 101	22p	2N 711	33p	2N 2926(O)	12p	2N 3905	31p	40263	49p
AC 208	22p	BC 125	11p	BC 225	12p	BF 127	55p	BSX 37	16p	OC 102	22p	2N 711	33p	2N 2926(O)	12p	2N 3905	31p	40263	49p
AC 209	22p	BC 126	11p	BC 226	12p	BF 127	55p	BSX 38	16p	OC 103	22p	2N 711	33p	2N 2926(O)	12p	2N 3905	31p	40263	49p
AC 210	22p	BC 127	11p	BC 227	12p	BF 127	55p	BSX 39	16p	OC 104	22p	2N 711	33p	2N 2926(O)	12p	2N 3905	31p	40263	49p
AC 211	22p	BC 128	11p	BC 228	12p	BF 127	55p	BSX 40	16p	OC 105	22p	2N 711	33p	2N 2926(O)	12p	2N 3905	31p	40263	49p
AC 212	22p	BC 129	11p	BC 229	12p	BF 127	55p	BSX 41											

The largest selection

NEW LOW PRICE TESTED S.C.R.'S

PIV	1A	2A	3A	4A	5A	6A	7A	8A	9A	10A	15A	20A
50	0.25	0.27	0.31	0.38	0.51	0.55	0.64	0.69	1.24			
100	0.27	0.36	0.51	0.51	0.55	0.64	0.69	1.14				
200	0.38	0.49	0.54	0.54	0.62	0.67	0.82	1.76				
400	0.47	0.51	0.61	0.61	0.73	0.82	1.02	1.92				
600	0.58	0.62	0.75	0.75	0.84	1.06	1.37					
800	0.69	0.77	0.88	0.88	0.99	1.32	1.55	1.40				

SILICON RECTIFIERS—TESTED

PIV	300mA (D07)	500mA (S016)	1A (S016)	1.5A (S016)	3A (S010)	10A (S010)	30A (S032A)
£	0.04	0.05	0.05	0.07	0.15	0.23	0.66
100	0.04	0.06	0.05	0.14	0.17	0.25	0.82
200	0.06	0.10	0.06	0.15	0.22	0.26	1.10
400	0.06	0.14	0.07	0.22	0.30	0.40	1.37
600	0.07	0.17	0.11	0.25	0.37	0.49	2.01
800	0.11	0.18	0.12	0.27	0.40	0.60	2.20
1000	0.12	0.27	0.15	0.33	0.50	0.69	2.75
1200		0.35		0.42	0.62	0.82	

TRACS	2A	6A	10A
100	0.33	0.55	0.77
200	0.55	0.66	0.82
400	0.82	0.99	1.21

DIACS
FOR USE WITH TRIACS
BR100 (D32) 40ip each

FREE
One 50p Pak of your own choice free with orders valued 50 or over.

BRAND NEW TEXAS GERM. TRANSISTORS
Coded and Guaranteed
Pak No. EQVT
T1 8 21313 OC71
T2 8 D1374 OC75
T3 8 D1216 OC81D
T4 8 21381T OC81
T5 8 21382T OC82
T6 8 21344B OC84
T7 8 21345R OC85
T8 8 26378 OC78
T9 8 26399A 2N1302
T10 8 26747 AF117
All 55p each pak

2N2060 NPN SIL. DUAL TRANS. CODE D1699 TEXAS. Our price 27p each.

120VCB NIXIE DRIVER TRANSISTOR Sim BSX21 & C107. 2N1883 FULLY TESTED AND CODED ND 120 1-24 181p each. TO 5 N.P.N. 25 up 161p each. 100 up 151p each.

Sil. trans. suitable for P.E. Organ. Metal TO-18. Eqt. ZTX300 p6 each. Any Qty.

POWER TRANS BONAZARI

GENERAL PURPOSE GERM. PNP
Coded GP100. BRAND NEW TO-3 CASE. P088. REPLACE. —OC25-28-29-30-35-36. NKT 401-403-404-406-408-430-451-402-453. T19027-3098. 2N250A. 2N456A-457A-458A. 2N511 A & B. 2G-20-222. ETC.
VCBO 50V VCBO 50V IC 10A PT. 30 WATTS Ric 30-170.
PRICE 1-24 52p each 25-99 100 up 50 for 1-10 1000 for 18.18

SILICON High Voltage 500V PNP TO-3 case. O.P. Switching & Amplifier Applications. Brand new Coded R 2400 VCBO 250V/VCBO 100V IC 6A/30 Wats. HFE type 20/IT 5MHz. OUR PRICE EACH:
1-24 25-99 100 up 55p 44p each 41p each

AD161/AD162 P.N.P.
M/P COMP GERM TRANS. OUR LOWEST PRICE OF 61p PER PAIR

KING OF THE PAKS Unequalled Value and Quality

SUPER PAKS NEW BI-PAK UNTESTED SEMICONDUCTORS

Satisfaction GUARANTEED in Every Pak, or money back.

Pak No.	Description	Price
U1	120 Glass Sub-Min. General Purpose Germanium Diodes	55p
U2	60 Mixed Germanium Transistors AF/RF	55p
U3	75 Germanium Gold Bonded Sub-Min. like OA5, OA47	55p
U4	40 Germanium Transistors like OCB1, AC128	55p
U5	60 200mA Sub-Min. Silicon Diodes	55p
U6	30 Sil. Planar Trans. NPN like BSY95A, 2N706	55p
U7	16 Sil. Rectifiers Top-Hat 750mA Vltg. Range up to 1,000	55p
U8	50 Sil. Planar Diodes DO-7 Glass 250mA like OA200, 202	55p
U9	20 Mixed Voltages, 1 Watt Zener Diodes	55p
U10	20 BA550 charge storage Diodes DO-7 Glass	55p
U11	25 PNP Sil. Planar Trans. TO-5 like 2N132, 2N2904	55p
U12	12 Silicon Rectifiers Epoxy 500mA up to 800 PIV	55p
U13	30 PNP-NPN Sil. Transistors OC200 and 2S 104	55p
U14	150 Mixed Silicon and Germanium Diodes	55p
U15	25 NPN Sil. Planar Trans. TO-5 like BFY51, 2N697	55p
U16	10 3Amp Silicon Rectifiers Stud Type up to 1,000 PIV	55p
U17	30 Germanium PNP AF Transistors TO-5 like ACY 17-22	55p
U18	8 6Amp Silicon Rectifiers BYZ13 Type up to 600 PIV	55p
U19	25 Silicon NPN Transistors like IC108	55p
U20	12 1.5Amp Silicon Rectifiers Top-Hat up to 1,000 PIV	55p
U21	30 AF Germanium Alloy Transistors 2G300 Series & OC71	55p
U22	30 MADD's like MHz Series PNP Transistors	55p
U23	20 Germanium 1 Amp Rectifiers GJM Series up to 300 PIV	55p
U24	25 300 MHz NPN Silicon Transistors 2N708, BSY27	55p
U25	30 Fast Switching Silicon Diodes like IN914 Micro-Min.	55p
U26	12 NPN Germanium AF Transistors TO-1 like AC127	55p
U27	10 1 Amp SCR's TO-5 can, up to 600 PIV CR51 25 600	£1.10
U30	15 Plastic Silicon Planar Trans. NPN 2N2926	55p
U31	20 Sil. Planar Plastic NPN Trans. Low Noise Amp 2N3707	55p
U32	25 Zener Diodes 400mW DO-7 case 3-18 volts mixed.	55p
U33	15 Plastic Case 1 Amp Silicon Rectifiers IN4000 Series	55p
U34	30 Silicon PNP Alloy Trans. TO-5 BCY26 2S302/1	55p
U35	75 Silicon Planar Transistors PNP TO-18 2N2906	55p
U36	25 Silicon Planar NPN Transistors TO-5 BFY50/51/52	55p
U37	30 Silicon Alloy Transistors SO-2 PNP OC200, 2S322	55p
U38	20 Fast Switching Silicon Trans. NPN 400 MHz 2N3011	55p
U39	30 RF. Germ. PNP Transistors 2N1303/5 TO-5	55p
U40	10 Dual Transistors 6 lead TO-5 2N2060	55p
U41	25 RF Germanium Transistors TO-5, OC45, NKT72	55p
U42	10 VHF Germanium PNP Transistors TO-1 NKT667, AF117	55p
U43	25 Sil. Trans. Plastic TO-18 A.F. RC115/114	55p
U44	20 Sil. Trans. Plastic TO-5 BC115/116	55p
U45	7 3A SCR. TO66 up to 600 PIV	£1.10

Code Nos. mentioned above are given as a guide to the type of device in the Pak. The devices themselves are normally unmarked.

SILICON PHOTO TRANSISTOR TO-18 Lens end NPN Sim. to BP 25 and P21. BRAND NEW. Full data available. Fully guaranteed. Qty. 1-24 25-99 100 up
Price each 50p 44p 27p

F.E.T.'S

2N3819	31p
2N3820	55p
2N3821	38p
2N3823	31p
2N5458	35p
2N5459	44p
BFW 10	66p
MPP105	40p

NEW EDITION 1971 TRANSISTOR EQUIVALENTS BOOK. A complete cross reference and equivalents book for European, American and Japanese Transistors. Exclusive to BI-PAK 99p each. Red cover edition.

2N3055
115 WATT SIL. POWER PNP. 55p EACH

A LARGE RANGE OF TECHNICAL AND DATA BOOKS ARE NOW AVAILABLE EX. STOCK. SEND FOR FREE LIST.

QUALITY TESTED SEMICONDUCTORS

Pack Description	Price 5p
Q1 20 Red spot transistors PNP	55p
Q2 18 White spot R.F. transistors PNP	55p
Q3 4 OC 77 type transistors	55p
Q4 6 Matched transistors OC44/45/81/81D	55p
Q5 4 OC 171 H.F. type transistors	55p
Q6 5 OC 72 transistors	55p
Q7 4 AC 128 transistors PNP high grain	55p
Q8 4 AC 128 transistors PNP	55p
Q9 7 OC 81 type transistors	55p
Q10 7 OC 71 type transistors	55p
Q11 2 AC 127/128 Comp pairs PNP/NPN	55p
Q12 3 AF 116 type transistors	55p
Q13 3 AF 117 type transistors	55p
Q14 3 OC 171 H.F. type transistors	55p
Q15 7 2N2926 Sil. Epoxy trans. and colours	55p
Q16 2 GET880 low noise Germ. trans.	55p
Q17 5 NPN 2 x ST. 141 and 3 x ST. 140	55p
Q18 4 MAT12 2 x MAT 100 & 2 x MAT 120	55p
Q19 3 MADD's 2 x MAT 101 & 1 x MAT 121	55p
Q20 4 OC 44 Germanium transistors A.F.	55p
Q21 1 AC 127 NPN Germanium transistors	55p
Q22 20 NKT transistors A.F. R.F. coded	55p
Q23 10 OA 202 Silicon diodes sub-min.	55p
Q24 8 OA 81 diodes	55p
Q25 15 IN914 Silicon diodes 76Piv 75mA	55p
Q26 8 OA5 Germanium diodes sub-min	55p
IN69	55p
Q27 2 10A 600 PIV Sil. rectifiers IS425/8	55p
Q28 2 Silicon power rectifiers BYZ 13	55p
Q29 4 Silicon trans. 2x 2N696, 1 x 2N697, 2 x 2N698	55p
Q30 7 Sil. switch transistors 2N706 NPN	55p
Q31 6 Sil. switch transistors 2N708 NPN	55p
Q32 3 PNP Sil. trans. 2CN113, 1x 2N1132	55p
Q33 3 Silicon NPN transistors 2N1711	55p
Q34 7 Sil. NPN trans. 2N2369, 500MHz (code P997)	55p
Q35 3 Sil. PNP TO-5, 2x 2N2904 & 1x 2N2905	55p
Q36 7 2N3646 TO-18 plastic 300 MHz NPN	55p
Q37 2 2N3053 NPN Silicon transistors	55p
Q38 7 PNP trans. 4 x 2N3703, 3 x 2N3702	55p
Q39 7 NPN trans. 3 x 2N3704, 3 x 2N3705	55p
Q40 7 NPN trans. 4x 2N3707, 3 x 2N3708	55p
Q41 3 Plastic NPN TO-18 2N3904	55p
Q42 6 NPN transistors 2N5172	55p
Q43 7 BC 107 NPN transistors	55p
Q44 7 NPN trans. 4 x BC 108, 3 x BC 109	55p
Q45 3 BC 113 NPN TO-18 transistors	55p
Q46 3 BC 115 NPN TO-5 transistors	55p
Q47 6 NPN high grain trans. 3 x BC167, 3 x HC168	55p
Q48 4 BCY 70 PNP transistors TO-18	55p
Q49 4 NPN trans. 2 x BFY51, 2 x BFY52	55p
Q50 7 BSY 29 NPN switch trans. TO-18	55p
Q51 7 BSY 96A NPN trans. 300MHz	55p
Q52 8 BY100 type silicon rectifiers	£1.10
Q53 25 Sil. & germ. trans. md all mkd new £1.65	

ELECTRONIC SLIDE-RULE

The MK Slide Rule, designed to simplify electronic calculations features the following scales—Conversion of Frequency and Wavelength, Calculation of L, C and f of tuned circuits, Resistance and self-inductance, Area of circles, Volume of cylinders, Resistance of conductors, Weight of conductors, Decibel calculations, Angle functions, Natural Logs, & e' functions, Multiplication & division, Squaring, cubing and square roots, Conversion of kW and Hp. A must for every electronic engineer and enthusiast. Size 23cm x 4 cm, complete with case and instructions. PRICE EACH: £3.88

DLT & TTL INTEGRATED CIRCUITS

INTEGRATED CIRCUIT PAKS

Manufacturers "Fall Out" which include Functional and part Functional Units. These are classed as "out-of-spec" from the maker's very rigid specifications, but are ideal for learning about I.C.'s and experimental work.

Pak No. Contents Price	Pak No. Contents Price	Pak No. Contents Price
UIC00 12 x 7400 55p	UIC46 5 x 7446 55p	UIC86 5 x 7486 55p
UIC01 12 x 7401 55p	UIC47 5 x 7447 55p	UIC90 5 x 7490 55p
UIC02 12 x 7402 55p	UIC48 5 x 7448 55p	UIC91 5 x 7491 55p
UIC03 12 x 7403 55p	UIC50 12 x 7450 55p	UIC92 5 x 7492 55p
UIC04 12 x 7404 55p	UIC51 12 x 7451 55p	UIC93 5 x 7493 55p
UIC08 12 x 7405 55p	UIC53 12 x 7453 55p	UIC94 5 x 7494 55p
UIC06 8 x 7406 55p	UIC54 12 x 7454 55p	UIC95 5 x 7495 55p
UIC07 8 x 7407 55p	UIC60 12 x 7460 55p	UIC96 5 x 7496 55p
UIC10 12 x 7410 55p	UIC70 8 x 7470 55p	UIC100 5 x 74100 55p
UIC13 8 x 7413 55p	UIC72 8 x 7472 55p	UIC121 5 x 74121 55p
UIC20 12 x 7420 55p	UIC73 8 x 7473 55p	UIC141 5 x 74141 55p
UIC30 12 x 7430 55p	UIC74 8 x 7474 55p	UIC151 5 x 74151 55p
UIC40 12 x 7440 55p	UIC75 8 x 7475 55p	UIC154 5 x 74154 55p
UIC41 5 x 7441 55p	UIC76 8 x 7476 55p	UIC193 5 x 74193 55p
UIC42 5 x 7442 55p	UIC80 5 x 7480 55p	UIC199 5 x 74199 55p
UIC43 5 x 7443 55p	UIC81 5 x 7481 55p	UIC X1 25 Assort.
UIC44 5 x 7444 55p	UIC82 5 x 7482 55p	74's £1.65
UIC45 5 x 7445 55p	UIC83 5 x 7483 55p	

Packs cannot be split, but 25 assorted pieces (our mix) is available as PAK UIC X1.

BI-PAKS NEW COMPONENT SHOP NOW OPEN WITH A WIDE RANGE OF ELECTRONIC COMPONENTS AND ACCESSORIES AT COMPETITIVE PRICES 18, BALDCKO STREET (A10), WARE, HERTS. TEL: 61593. OPEN MON. - SAT. 9.15 a.m. to 6 p.m. FRIDAY UNTIL 8 p.m.

All Mail Orders please add 10p post and packing. Send all Orders to Bi-Pak P.O. Box 6, Ware, Herts.

-the lowest prices!

74 Series T.T.L. I.C.'s

Bi-Pak 50H Lowest in Prices.
Full Specification Guaranteed.
All Famous Manufacturers.

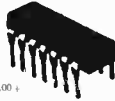

	1	25	100		1	25	100
SN7400	0.161	0.151	0.13	SN7480	0.731	0.701	0.64
SN7401	0.161	0.151	0.13	SN7491	£1.10	£1.04	0.99
SN7402	0.161	0.151	0.13	SN7492	0.731	0.701	0.64
SN7403	0.161	0.151	0.13	SN7493	0.731	0.701	0.64
SN7404	0.161	0.151	0.13	SN7494	0.94	0.91	0.75
SN7405	0.161	0.151	0.13	SN7495	0.94	0.91	0.75
SN7406	0.381	0.34	0.31	SN7496	0.94	0.91	0.75
SN7407	0.381	0.34	0.31	SN7497	0.94	0.91	0.75
SN7408	0.20	0.18	0.17	SN7498	0.94	0.91	0.75
SN7409	0.20	0.18	0.17	SN7499	0.94	0.91	0.75
SN7410	0.161	0.151	0.13	SN74100	£1.061	£1.031	0.97
SN7411	0.271	0.261	0.251	SN74107	0.41	0.42	0.391
SN7412	0.381	0.34	0.31	SN74110	0.661	0.581	0.55
SN7413	0.32	0.281	0.251	SN74111	£1.371	£1.261	£1.21
SN7414	0.471	0.44	0.42	SN74118	£1.10	£1.04	0.99
SN7415	0.40	0.44	0.42	SN74119	£1.481	£1.371	£1.31
SN7420	0.161	0.151	0.13	SN74121	0.44	0.40	0.371
SN7421	0.55	0.53	0.49	SN74122	£1.54	£1.43	£1.21
SN7423	0.55	0.53	0.49	SN74123	£3.08	£2.97	£2.88
SN7425	0.55	0.53	0.49	SN74141	0.731	0.701	0.64
SN7426	0.481	0.46	0.44	SN74142	£1.88	£1.84	£1.75
SN7427	0.481	0.46	0.44	SN74150	£3.30	£2.97	£2.75
SN7428	0.77	0.71	0.66	SN74151	£1.10	£1.04	0.99
SN7430	0.161	0.151	0.13	SN74152	£1.32	£1.21	£1.14
SN7432	0.48	0.46	0.44	SN74154	£1.98	£1.87	£1.76
SN7433	0.80	0.821	0.77	SN74155	£1.54	£1.43	£1.32
SN7437	0.701	0.66	0.66	SN74156	£1.54	£1.43	£1.32
SN7438	0.701	0.66	0.66	SN74157	£2.50	£1.98	£1.87
SN7440	0.161	0.151	0.13	SN74158	£1.98	£1.87	£1.76
SN7441	0.731	0.701	0.64	SN74161	£1.98	£1.87	£1.76
SN7442	0.731	0.701	0.64	SN74162	£4.40	£4.121	£3.95
SN7443	£1.43	£1.371	£1.32	SN74163	£4.40	£4.121	£3.95
SN7444	£1.43	£1.371	£1.32	SN74164	£2.60	£2.50	£2.31
SN7445	£1.98	£1.84	£1.75	SN74165	£2.71	£2.42	£2.31
SN7446	£1.061	£1.031	0.97	SN74166	£3.85	£3.571	£3.30
SN7447	£1.10	£1.061	£1.04	SN74171	£2.141	£2.12	£2.03
SN7448	£1.10	£1.061	£1.04	SN74175	£1.76	£1.65	£1.54
SN7450	0.161	0.151	0.13	SN74176	£2.75	£2.64	£2.53
SN7451	0.181	0.151	0.13				
SN7453	0.181	0.151	0.13				
SN7454	0.181	0.151	0.13				
SN7455	0.181	0.151	0.13				
SN7456	0.181	0.151	0.13				
SN7457	0.32	0.281	0.251				
SN7458	0.32	0.281	0.251				
SN7459	0.401	0.381	0.35				
SN7474	0.401	0.381	0.35				
SN7475	0.491	0.47	0.45				
SN7476	0.44	0.43	0.42				
SN7480	0.731	0.701	0.64				
SN7481	£1.201	£1.201	£1.21	SN74193	£2.20	£2.06	£1.921
SN7482	0.951	0.94	0.931	SN74194	£2.97	£2.86	£2.75
SN7483	£1.31	£1.151	£1.04	SN74195	£2.20	£2.06	£1.921
SN7484	£1.10	£1.04	0.99	SN74196	£1.98	£1.87	£1.76
SN7485	£3.98	£3.85	£3.74	SN74197	£1.98	£1.87	£1.76
SN7486	0.55	0.54	0.53	SN74198	£6.05	£5.90	£5.95
SN7489	£8.05	£5.771	£5.50	SN74199	£6.05	£5.90	£5.95

BI-PAK DO IT AGAIN!

50Wpk 25w (RMS)

0.1% DISTORTION

HI-FI AUDIO AMPLIFIER THE AL50

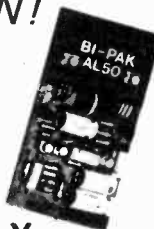

★ Frequency response 15Hz to 100,000 - 1dB. **ONLY**

★ Load - 3, 4, 8 or 16 ohms. **£3.58 each**

★ Distortion - better than 0.1% at 1KHz. **★ Supply voltage 10 - 35 Volts.**

★ Signal to noise ratio 80dB. **★ Overall size 63mm x 105mm x 13mm.**

Tailor made to the most stringent specifications using top quality components and incorporating the latest solid state circuitry and ALSO was conceived to fill the need for all your A.F. amplification needs. **FULLY BUILT - TESTED - GUARANTEED.**

STABILISED POWER MODULE SPM80



AP80 is especially designed to power 2 of the AL50 Amplifiers, up to 15 watt (rms) per channel, simultaneously. This module embodies the latest components and circuit techniques incorporating complete short circuit protection. With the addition of the Mains Transformer MT80, the unit will provide outputs of up to 1.5 amps at 35 volts. Size: 62mm x 105mm x 30mm.

These units enable you to build Audio Systems of the highest quality at a hitherto unobtainable price. Also ideal for many other applications including: Disco Systems, Public Address, Intercom Units etc. Handbook available 10p.

PRICE £3.25

TRANSFORMER BMT80 £2.15 p. & p. 25p.

STEREO PRE-AMPLIFIER, TYPE PA100

Built to a specification and NOT a price, and yet still the greatest value on the market, the PA100 stereo pre-amplifier has been conceived from the latest circuit techniques. Designed for use with the AL50 power amplifier system, this quality made unit incorporates no less than eight silicon planar transistors, two of these are specially selected low noise NPN devices for use in the input stages.

Three switched stereo inputs, and rumble and scratch filters are features of the PA100, which also has a STEREO/MONO switch, volume, balance and continuously variable bass and treble controls.



SPECIFICATION

Frequency Response 20Hz - 20KHz ± 1dB
 Harmonic Distortion better than 0.1%
 Inputs: 1. Tape Head 1.25 mV into 50KΩ
 2. Radio, Tuner 36 mV into 50KΩ
 3. Magnetic P.U. 1.5 mV into 50KΩ
 All input voltages are for an output of 250mV. Tape and P.U. inputs equalised to RIAA curve within ± 1dB, from 20Hz to 20KHz.
 Base Control ± 16dB @ 20Hz
 Treble Control ± 16dB @ 20KHz
 Filters: Rumble (High Pass) 100Hz
 Scratch (Low Pass) 8KHz
 Signal/Noise Ratio better than - 66dB
 Input overload + 36dB Supply
 Dimensions 292mm x 62mm x 30mm

Price £13.15

SPECIAL COMPLETE KIT COMPRISING 3 AL50's, 1 SPM80, 1 BMT80 and 1 PA100 ONLY £25.30 FREE p. & p.

All prices quoted in new pence Cir No 388 7006

Please send all orders direct to warehouse and despatch department

BI-PAK

P.O. BOX 6, WARE, HERTS

Postage and packing add 10p Overseas add extra for airmail
 Minimum order 50p. Cash with order please.

Guaranteed Satisfaction or Money Back

LINEAR I.C.'s— FULL SPEC.

Type No.	1-24	25-99	100 up
BP 801C—GL801C	48p	58p	49p
BP 701C—GL701C	69p	55p	49p
BP 702C—SL702C	69p	55p	49p
BP 702—72702	58p	49p	44p
BP 708—72708	39p	37p	35p
BP 709P—LA709C	39p	37p	33p
BP 710—72710	48p	36p	44p
BP 711—LA711	49p	47p	44p
BP 741—72741	55p	50p	45p
LA 708C—LA708C	31p	28p	26p
TA A263	77p	66p	60p
TA A268	99p	82p	77p
TA A360	187p	174p	165p

EA1000 £2.89j

LOGIC DTL 930 SERIES I.C.'s ROCK BOTTOM PRICES

Type No.	1-24	25-99	100 up
BP930	18p	12p	11p
BP932	14p	13p	12p
BP933	14p	13p	12p
BP935	14p	13p	12p
BP936	14p	13p	12p
BP944	14p	13p	12p
BP945	27p	26p	24p
BP946	15p	12p	11p
BP948	27p	26p	24p
BP949	71p	66p	60p
BP950	13p	12p	11p
BP9503	44p	42p	38p
BP9504	44p	42p	38p
BP9507	34p	42p	38p
BP9509	44p	42p	38p

Devices may be mixed to quality for quantity price. Larger quantity prices on application. (DTL 930 Series only).

NUMERICAL INDICATOR TUBES



MODEL	CD66	GR 116	3015F
Anode voltage (Vdc)	170 min	175 min	5
Cathode cur'nt (mA)	2.3	14	
Numeral h'ght (mm)	16	13	9
Tube height (mm)	47	32	22
Tube diameter (mm)	19	13	12
I.C. driver rec.	BP41 or 141	BP41 or 141	BP47
PRICE EACH	£1.87	£1.71	£2.09

All indicators 0.9 + Decimal point: All side viewing: Full data for all types available on request.

ETL MICROLOGIC CIRCUITS

	Price each:	1-24	25-99	100 up
Epoxy TO-3 case				
uL900 Buffer		39p	36p	30p
uL914 Dual V/1p				
644		39p	36p	30p
uL915 J-K flip-flop		55p	52p	50p

Date and Circuits Booklet for IC's Price 7p.

DUAL IN LINE SOCKETS 14 & 16 Lead Sockets for use with DUAL IN-LINE I.C.'s. TWO RANGES PROFESSIONAL and NEW LOW COST.

Prof. Type No.	1-24	25-99	100 up
TS014 pin type	33p	30p	27p
TS016 pin type	38p	35p	33p
Low Cost No.			
BPS 14	16p	14p	12p
BPS 16	17p	15p	13p

Now! A FAST EASY WAY TO LEARN BASIC RADIO & ELECTRONICS



Build as you learn with the exciting new **TECHNATRON** Outfit! No mathematics. No soldering—you learn the *practical way*.

Learn basic Radio and Electronics at home – the fast, modern way. Give yourself essential technical ‘know-how’ – like reading circuits, assembling standard components, experimenting, building – quickly and without effort, and enjoy every moment. B.I.E.T.’s simplified study method and the remarkable **TECHNATRON** Self-Build Outfit take the mystery out of the subject, making learning easy and interesting.

Even if you don't know the first thing about Radio now, you'll build your own Radio set within a month or so!

and what's more, you will understand exactly what you are doing. The **TECHNATRON** Outfit contains everything you need, from tools to transistors – even a versatile Multimeter which we teach you to use. All you need give is a little of your spare time and the surprisingly low fee, payable monthly if you wish. And the equipment remains yours, so you can use it again and again.

You LEARN – but it's as fascinating as a hobby.

Among many other interesting experiments, the Radio set you build – and it's a good one – is really a bonus. This is first and last a teaching course, but the training is as fascinating as any hobby and it could be the springboard for a career in Radio and Electronics.

A 14-year-old could understand and benefit from this course – but it teaches the real thing. The easy to understand, practical projects – from a burglar-alarm to a sophisticated Radio set – help you master basic Radio and Electronics – even if you are a ‘non-technical’ type. And, if you want to make it a career, B.I.E.T. has a fine range of courses up to City and Guilds standards.

Specialist Booklet

If you wish to make a career in Electronics, send for your **FREE** copy of “**NEW OPPORTUNITIES**”. This brand new booklet – just out – tells you all about **TECHNATRON** and B.I.E.T.’s full range of courses.



FREE

BRITISH INSTITUTE OF ENGINEERING TECHNOLOGY

Dept. BRE 06 ALDERMASTON COURT, READING RG7 4PF
Accredited by the Council for the Accreditation of Correspondence Colleges.

POST THIS COUPON FOR FREE BOOK

CL BRE 06

NAME..... (BLOCK CAPITALS) AGE.....

ADDRESS.....

.....

SUBJECT OF INTEREST.....

LATEST BOUND VOLUME No. 25

of

“The Radio Constructor” FOR YOUR LIBRARY

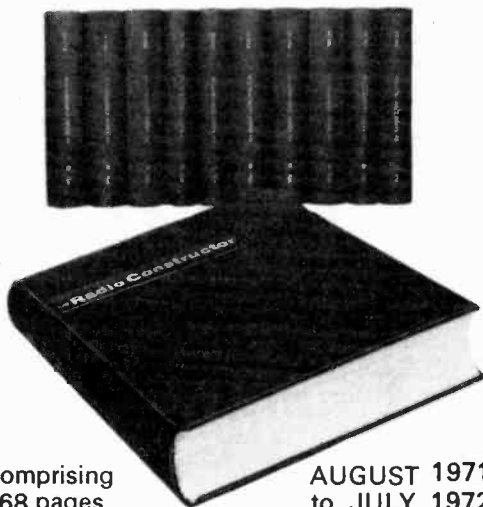

Comprising 768 pages plus index

AUGUST 1971 to JULY 1972

PRICE £2.00 P. and P. 29p

BOUND VOLUME NO. 23
(August 1969 to July 1970)

BOUND VOLUME NO. 24
(August 1970 to July 1971)

Limited number of these volumes still available.

PRICES

Volume 23 £1.88 P. & P. 29p

Volume 24 £2.00 P. & P. 29p

We regret all earlier volumes are now completely sold out.

Available only from

DATA PUBLICATIONS LTD.,
57 MAIDA VALE, LONDON, W9 1SN

BI-PRE-PAK



COMPLETE TELEPHONES
Normal household type as supplied to the Post Office, ex. G.P.O. Only **95p** each. p. & p. 35p each.

TELEPHONE DIALS
Standard Post Office type. Guaranteed in working order
ONLY 25p
p. & p. 15p.

TESTED AND GUARANTEED PAKS

B2	4	Photo Cells, Sun Batteries. 0.3 to 0.5V. 0.5 to 2mA.	50p
B79	4	1N4007 Sil. Rec. diodes. 1,000 PIV lamp plastic.	50p
B81	10	Reed Switches, 1" Long 1/2" Dia. High speed P.O. type	50p
B99	200	Mixed Capacitors. Approx. quantity, counted by weight.	50p
H4	250	Mixed Resistors. Approx. quantity counted by weight	50p
H7	40	Wirewound Resistors. Mixed types and values.	50p
H9	2	OCPT1 Light Sensitive Photo Transistor	50p
H28	20	OC200/1/2/3 PNP Silicon uncod. TO-5 Can.	50p
H30	20	1 Watt Zener Diodes. Mixed Voltages 6.8 - 43V	50p
H35	100	Mixed Diodes. Germ. Gold bonded, etc. Marked and Unmarked	50p
H38	30	Short lead Transistors. NPN Silicon Planar types	50p
H39	10	Integrated Circuits: 4 Gates. BMC 962.4 Flip Flops. BMC 945	50p
H40	20	BFY502, 2N1696, 2N1613. NPN Silicon uncod. TO-5	50p

UNMARKED UNTESTED PACKS

B66	150	Germanium Diodes Min. glass type	50p
B83	200	Trans. manufacturers' rejects all types NPN, PNP, Sil. and Germ.	50p
B84	100	Silicon Diodes DO-7 glass equiv. to OA200, OA202	50p
B86	100	Sil. Diodes sub. min. 1N914 and 1N916 types	50p
B88	50	Sil. Trans. NPN, PNP equiv. to OC200/1, 2N706A, 85Y95A, etc.	50p
B1	50	Germanium Transistors PNP, AF, & RF.	50p
H6	40	250mW Zener Diodes DO-7 Min. Glass Type	50p
H34	15	Power Transistors, PNP, Germ. NPN Silicon TO-3 Can.	50p
H17	20	3amp Silicon Stud rectifiers, mixed volts.	50p
H15	30	Top Hat Silicon Rectifiers. 750mA. Mixed volts.	50p
H16	15	Experimenters' Pak of Integrated Circuits. Data supplied	50p
H20	20	BY126/7 Type Silicon Rectifiers 1 amp plastic. Mixed volts.	50p

MAKE A REV COUNTER FOR YOUR CAR

The 'TACHO BLOCK'. This encapsulated block will turn any 0-1mA meter into a linear and accurate rev. counter for any car with normal coil ignition system.

£1 each



OVER TRANSISTORS IN STOCK 1,000,000

We hold a very large range of fully marked, tested and guaranteed transistors, power transistors, diodes and rectifiers at very competitive prices. Please send for free catalogue.

600,000 Silicon planar plastic transistors. Unmarked, untested, factory clearance. A random sampling showed these to be of remarkably high quality.
Aucio PNP, similar to ZTX500, 2N3702/3, BC~70, etc.
Aucio NPN, similar to ZTX300, 2N3708/9, BC107/8/9, BC168/9, etc.
R.F. NPN and switching NPN Types also. Please state type of transistor required when ordering.
ALL AT 500 for £3, 1,000 for £5, 10,000 for £40

OUR VERY POPULAR 3p TRANSISTORS
TYPE "A" PNP Silicon Alloy, TO-5 can.
TYPE "B" PNP Silicon, plastic encapsulation.
TYPE "E" PNP Germanium AF or RF.
TYPE "F" NPN Silicon plastic encapsulation.
TYPE "G" NPN Silicon, similar ZTX300 range.
TYPE "H" PNP Silicon, similar ZTX500 range.

8 RELAYS FOR VARIOUS TYPES P & P 25p £1

VALUE ADDED TAX

On orders of £4 or over. See below: Please read very carefully:

We will give a discount to customers who send in an order for £4 or over. This discount will be equal to the V.A.T. rate current at this time. If your order does amount to £4 or over, all you need to send is the total cost of goods and postage as stated in this advertisement. No addition or V.A.T. is needed. V.A.T. for orders under £4: If the total cost of goods plus postage and packing is less than £4, kindly add 10% (10p in the £) to your remittance. Incorrect amounts will delay your order.



A CROSS HATCH GENERATOR FOR £3.50 !!!

YES, a complete kit of parts including Printed Circuit Board, A four position switch gives X-hatch, Dots, Vertical or Horizontal lines, Integrated Circuit design for easy construction and reliability. This is a project in the September edition of Practical Television.

This complete kit of parts costs £3.50, post paid.

A MUST for Colour T.V. Alignment.

Our famous P1 Pak is still leading in value for money.

Full of Short Lead Semiconductors & Electronic Components, approx. 170. We guarantee at least 30 really high quality factory marked Transistors PNP & NPN, and a host of Diodes & Rectifiers mounted on Printed Circuit Panels. Identification Chart supplied to give some information on the Transistors

Please ask for Pak P1, only 50p 10p P & P on this Pak.

FREE CATALOGUE FOR TRANSISTORS, RECTIFIERS, DIODES, INTEGRATED CIRCUITS, FULL PRE-PAK LISTS.



100,000 Plastic Power Transistors

in stock, more on way

NOW IN TWO RANGES

These are 40W and 90W Silicon Plastic Power Transistors of the very latest design, available in NPN or PNP at the most shattering low prices of all time. We have been selling these successfully in quantity to all parts of the world and we are proud to offer them under our Tested and Guaranteed terms.

Range 1. VCE. Min 15.	HFE Min 15.	1-12	13-25	26-50
40 Watt	20p	24p	18p	16p
90 Watt	24p	22p	20p	20p
Range 2. VCE. Min 40.	HFE Min 40.	1-12	13-25	26-50
40 Watt	30p	28p	26p	26p
90 Watt	35p	33p	30p	30p

Complementary pairs matched for gain at 3 amps. 10p extra per pair. Please state NPN or PNP on order.

INTEGRATED CIRCUITS. We stock a large range of I.C.s at very competitive prices (from 10p each). These are all listed in our FREE Catalogue, see coupon below.

METRICATION CHARTS now available. This fantastically detailed conversion calculator carries thousands of classified references between metric and British (and U.S.A.) measurements of length, area, volume, liquid measure, weights, etc. Pocket Size. 15p. Wall Chart. 18p.

LOW COST DUAL IN LINE I.C. SOCKETS
14 pin type at 15p each. Now new low profile type.
16 pin type at 16p each.

BOOKS

We have a large selection of Reference and Technical Books in stock.

These are just two of our popular lines:
B.P.I. Transistor Equivalents and Substitutes: 40p
This includes many thousands of British U.S.A., European and C.V. equivalents.
The Hi-Fi Radio Valve & Transistor Data Book 9th Edition P & P 21p 75p
Characteristics of 3,000 valves and tubes, 4,500 Transistors, Diodes, Rectifiers and Integrated Circuits.
Send for lists of publications.

Please send me the FREE Bi-Pre-Pak Catalogue

NAME

ADDRESS

MINIMUM ORDER 50p CASH WITH ORDER PLEASE. Add 10p post and packing per order. OVERSEAS ADD EXTRA FOR POSTAGE

BI-PRE-PAK LTD

Co. Regd. No. 820919

DEPT. C, 222-224 WEST ROAD, WESTCLIFF-ON-SEA, ESSEX, SS0 9DF
TELEPHONE: SOUTHEM (0702) 46344

COMPONENTS

HOBBYIST - AMATEUR - DOMESTIC SURPLUS - INDUSTRIAL - BULK OFFERS
JUST A FEW OF OUR BARGAINS ARE LISTED BELOW - PAY US A VISIT OR SEND STAMPED ADDRESSED ENVELOPE FOR A QUOTE ON YOUR REQUIREMENTS

MAINS POWER SUPPLY UNIT. 400m/A, 6-7.5-9-12 VOLT MADE TO SELL AT £5.25 OUR PRICE £3.50

VALVE BASES	
Chassis or printed circuit B9A - B7G	3p
Chassis UX7 - B5 - UX5 - B9G	3p
Shrouded chassis B7G - B9A	4p
Octal chassis	4p
B8A chassis	5p
B12A tube base	3p

TAG STRIP			
6 way	2p	Single	1p

1 1/4 glass fuses— 250 m/a or 3 amp (box of 12)	6p
3" tape spools	4p
FX2236 Ferrox Cores	5p
PVC or metal clip on M.E.S. bulb holder	3p
All metal equipment Phono plug	2p
Bulgin, 5mm Jack plug and switched socket (pair)	20p
12 volt solenoid and plunger	25p
250 RPM 50 c/s locked frequency miniature mains motor	50p
200 OHM coil, 1 1/4" long, hollow centre	10p
Relay, P.O. 3000 type, 1,000 OHM coil, 4 pole c/o	60p
R.S. 12 way standard plug and shell	50p

SWITCHES			
Pole	Way	Type	
4	2	Sub. Min. Slide	10p
6	4	} Wafer Rotary	12p each
4	3		
3	7		
2	5		
1	3	+ off Sub. min. edge	10p
1	3	13 amp small rotary	12p
2	2	Locking with 2 to 3 keys	£1.50
2	1	2 Amp 250V A.C. rotary	20p
2	1	Toggle	10p

VALVES - NEW AND BOXED			
DY86	44p	EM87	90p
EB91	26p	EL84	36p
ECC82	36p	EY86	46p
ECC83	36p	EZ80	30p
ECH81	44p	PCC84	50p
EABC80	46p	PCC89	62p
EBF89	44p	PCF80	38p
ECL82	44p	PCF82	50p
ECL86	56p	PCL82	38p
EF80	36p	PCL84	50p
EF85	44p	PCL85	64p
EF86	44p	PCL86	56p
EF91	52p	PL36	78p
EF183	40p	PL81	72p
EF184	44p	PL83	56p
		PL84	46p
		PY81	40p
		PY82	42p
		PY88	52p
		UABC80	58p
		UCL82	50p
		UL84	50p
		UY85	42p
		UM84	32p
		UCH81	44p
		6BA6	26p
		12E1	£2.50
		SIIE12	£5.00
		MANY OTHERS	

RESETTABLE COUNTER	
English Numbering Machines LTD.	
MODEL 4436-159-989	
6-14 volt, 6 digit, illuminated, fully enclosed. £2.50	

TO3 Mica Washer	2p
3" Standard Tape - Boxed	15p
GP91-1 Cartridge, turnover stylii	65p
GC10/4B Cold Cathode	£5.00

1/4 - 1/2 watt	1p
1 watt	1 1/2p
Up to 10 watt wire	8p
15 watt wire wound	10p

RESISTORS	
1/4 - 1/2 watt	1p
1 watt	1 1/2p
Up to 10 watt wire	8p
15 watt wire wound	10p

SKELETON PRESETS	
5K or 500K	3p

SAFETY PINS	
Standard size, 10 for 4p	

THORN PTO2E 10-6s CHASSIS SOCKET 40p	
5K switched volume control	15p
5K Log Pot	10p
1meg Tandem Pot	15p

THERMISTORS	
VA1040	
VA1055	
VA1066	10p each
VA1077	
VA1100	

STEEL BOX WITH LID	
10 x 5 1/2 x 3" grey hammer finish	£1

RELAY	
6 volt, 2 pole c/o heavy duty contacts	50p

ELECTROLYTICS			
Mullard C426, TCC, CRL, CCL, HUNTS. STC SUB MINIATURE, ETC.			
MFD	Volt	MFD	Volt

16	50	20	12	} 4p each
260	12	500	6	
50	50	100	25	} 2p each
100	18	100	6	
125	10	6	3	} 3p
8	50	8	6	
12	20	25	6.4	} 7p
10	20	250	18	
8.2	20	400	16	} 6p
50	25	400	40	
2.5	64	8	500	} 9p
25	25	100	200	

CONDENSERS	
MFD	Volt

0.005	500	} 2p each
0.001	1,250	
3.3PF	500	} 2p each
500 PF	500	
2,200PF	500	} 3p each
3,300PF	500	
0.1	350	} 5% 350V
0.1	500	
0.25	150	} 4p each
0.056		
0.061		} 5p each
0.069		
0.075		} 5p each
0.08		
0.1	1,500	} 4p each
0.25	350	
0.5	350	} 5p each
0.22	250	
0.25	500	} 5p each

TUNING GANG	
100PF, 50PF, 33PF	20p each

TRIMMERS	
30PF Beehive	} 10p each
12PF P.T.F.E.	
2,500PF 750V	
33PF MIN. AIR SPACE	

WIREWOUND POTS	
250, 300 OHM, 1K, 4 watt, 10K, 20K, 50K, all at	10p each

RECORD PLAYER CARTRIDGE	
ER.5XME Mono, with turn over stylii, single hole fixing	35p

GREEN INDICATOR	
Takes M.E.S bulb	10p

CONNECTOR STRIP	
Belling Lee L1469, 12 way polythene.	5p each

CAN CLIPS	
1" or 1 1/8" or 3/4"	2p

T.O.5 HEATSINKS	
Style 154 high conductivity	5p

PAXOLINE	
2 3/8 x 4 1/2 x 1/8" or 3 x 2 1/2 x 1/8"	2p
4 3/8 x 1 1/2 x 1/8"	2 for 1p

VALVE RETAINER CLIP, adjustable	
220K 3 watt resistors	2p

OUTPUT TRANSFORMERS	
Sub-miniature Transistor Type	20p

3 pin din to open end, 1 1/2yd twin screened lead	35p
---	-----

10 mtrs loudspeaker extension lead fitted 2 pin din plug and socket	40p (retail 70p)
---	------------------

THE RADIO SHACK

161 ST. JOHNS HILL, BATTERSEA, LONDON S.W.11
Open 10 a.m. till 7 p.m. Monday to Saturday Phone 01-223 5016

SEMICONDUCTORS

Full spec. marked by Mullard, etc. Many other types in stock

AC127 .. 10p	BC149 .. 8p	BFX30 .. 25p
AC187/8 .. 14p	BC157 .. 12p	BFX88 .. 20p
AD149 .. 35p	BC158 .. 8p	BSV64 .. 40p
AD161 .. 27p	BC159 .. 12p	BU105/01 .. £1.75
AD162 .. 27p	BCY40 .. 25p	OC35 .. 28p
Matched pair .. 50p	BCY70 .. 14p	2N706 .. 8p
AF116 .. 12p	BCY71 .. 18p	2N219 .. 19p
AF117 .. 12p	BD131 .. 40p	2N2401 .. 15p
AF139 .. 28p	BD132 .. 50p	2N2904 .. 17p
AF178 .. 40p	BD135 .. 26p	2N2905 .. 21p
AF180 .. 45p	BF115 .. 23p	2N2906 .. 15p
AF239 .. 30p	BF179 .. 30p	2N2907 .. 18p
BC107/8/9 .. 7p	BFY51 .. 10p	2N3055 .. 35p
BC147 .. 8p	BFY52 .. 12p	2N3053 .. 15p
BC148 .. 8p	BFX29 .. 25p	

BRIDGE RECTIFIERS

Amp	Volt	Type	Price
1	1,600	BYX10	30p
1	140	OSH01-200	30p
1.4	42	BY164	35p

Plastic types

1 AMP RECTIFIERS

IN4002	100 volt	4p
IN4003	200 volt	5p
IN4004	400 volt	7p
IN4005	600 volt	9p
IN4006	800 volt	10p
IN4007	1,000 volt	15p

HIGH POWER RECTIFIERS

Type	Amp	Volt	Price
BYX38-600	2.5	600	25p
BYX38-300	2.5	300	20p
BYX38-900	2.5	900	28p
BYX38-1200	2.5	1,200	30p
BYX49-600	2.5	600	25p
BYX49-300	2.5	300	20p
BYX49-900	2.5	900	28p
BYX48-300	6	300	27p
BYX48-600	6	600	32p
BYX48-900	6	900	40p
BYX48-1200	6	1,200	60p
BYX72-150R	10	150	24p
BYX72-300R	10	300	35p
BYX72-500R	10	500	43p
BYX42-300	10	300	40p
BYX42-600	10	600	45p
BYX42-900	10	900	55p
BYX42-1200	10	1,200	75p
BYX46-300*	15	300	2.50
BYX46-400*	15	400	£2.90
BYX46-500*	15	500	£3.20
BYX46-600*	15	600	£3.80
BYX20-200	25	200	35p
BYX52-300	40	300	£1.75
BYX52-1200	40	1,200	£2.25

*Avalanche type

N50 ohm free plug (UG21D/U)	50p
N50 ohm square socket (UG58A/U)	50p
1" Terryclips black plastic coated, or chrome finish	4p
Cinch 10-way terminal block	15p
Pair of LA2407 Ferroxc cores with adjuster	25p
Chrome Car Radio fascia	15p
Rubber Car Radio gasket	10p
DLI Pal Delayline	£2.00
Relay socket	12p
Take miniature 2PCO relay	
B9A valve can	2p
0-30 in. 5 segments, black pvc, 360° dial, silver digits, self adhesive, 4 1/2" dia.	15p

OPTO ELECTRONICS

ORP12	43p	Photo transistor	
BPX40	25p	BPX29	80p
BPX42	£1	OCF71	30p
BPY10	75p		
BPY68	75p		
BPY69	£1		
BPY77	75p		

Diodes

Photo transistor	
BPX29	80p
OCF71	30p

CQ11B	
Infra red transmitter	£4

F.E.T.'s

BFW10	40p
BSV79	90p
BSV80	80p
N. Channel	
BSV81 M.O.S.T.	£1
BFS28 Dual M.O.S.T.	90p

Plastic, Transistor or Diode Holder 1p
Transistor or Diode Pad 1p

Phillips Iron Thermostat	15p
Bulgin 2-pin flat plug and socket	10p
McMurdo PP108 8 way edge plug	15p
300 ohm moving coil insert 4103D 1 1/2" diameter. Make ideal mike or speaker for communication work	25p

TESTED UNMARKED OR MARKED AMPLE LEAD EX NEW EQUIPMENT

AC128	6p	OC44	6p
ACY17-20	8p	OC71	6p
BCY70/1/2	8p	OC72	6p
BCY30-34	10p	OC200-5	6p
BY127	8p	2N2926	5p
BZY88 series	6p	Germanium diode	3p
OA5/7/10	10p	GET111	20p
OA47/81	4p	GET120	
OA200-5	6p	(AC128 In 1" sq. heat sink)	20p
OC23	20p		
OC29	25p		

THYRISTORS

Amp	Volt	Type	Price
1	240	BTX18-200	30p
1	240	BTX30-200	30p
5.6	700	BT106	85p
6.5	300	BT102-300R	42p
6.5	500	BT102-500R	60p
6.5	500	BT107	90p
6.5	500	BT108	90p
6.5	500	BT101-500R	68p
6.5	500	BT109-500R	90p
20	600	BTW92-600RM	£3.00
15	800	BTX95-800R Pulse Modulated	£12

OTHER DIODES

Centercel	5p
IN916	6p
BA145	14p

TRIACS

Amp	Volt	Type	Price
6	400	BT110-400 Plastic	75p
25	900	BTX94-900	£6.50
25	1200	BTX94-1200	£9

DIAC BRI00	30p
------------	-----

PHOTO SILICON CONTROLLED SWITCH BPX66 PNP 10 amp	£1
--	----

PAPER BLOCK CONDENSER

0.25MFD	800 volt	30p
1MFD	400 volt	15p
2MFD	250 volt	20p
2MFD	1.5 kv	50p
15MFD	150 volt	25p

WIREWOUND SLIDER

150 Ohm, 250 Ohm 5K
4p each

INDICATORS

12 volt red or mains neon amber, push fit round, chrome bezel
15p each

Rotor with neon indicator, as used in Seafarer, Pacific, Fairway depth finders
20p each

100MFD 250/275V electrolytic can
20p

DEE PLUG

McMurdo DA15P 15 way chassis plug
20p

Fairway 18009 Coax. socket
5p

TIE CLIPS

Nylon self locking 3 1/2" 1p; 7" 2p

CINCH 150

12 way edge socket
10p

ALL ORDERS OVER £3 POST FREE OVER £6 V.A.T. FREE

SMALL ORDERS, ENCLOSE SUITABLE STAMPED ADDRESSED ENVELOPE
LARGE ORDERS, ADD SUFFICIENT FOR POSTAGE, INSURANCE, ETC.
TOTAL GOODS PLUS CARRIAGE, ADD 10% V.A.T.

THE RADIO SHACK

161 ST. JOHNS HILL, BATTERSEA, LONDON S.W.11

Open 10 a.m. till 7 p.m. Monday to Saturday

Phone 01-223 5016

THE MODERN BOOK CO

THE RADIO AMATEUR'S HANDBOOK 1973

by The American Radio Relay League Price £2.95

UNDERSTANDING ELECTRONIC CIRCUITS

by I. R. Sinclair £3.60

HOW TO GET THE BEST OUT OF YOUR

TAPE RECORDER by P. J. Guy £1.60

125 ONE-TRANSISTOR PROJECTS

by R. P. Turner £1.40

DIGITAL LOGIC BASIC THEORY & PRACTICE

by J. H. Smith £1.60

TEST INSTRUMENTS FOR ELECTRONICS

by M. Clifford £1.40

RAPID TV REPAIR

by G. W. Heath £1.40

INSTALLING & SERVICING ELECTRONIC

PROTECTIVE SYSTEMS

by H Swearer £1.40

MAKING TRANSISTOR RADIOS

A BEGINNER'S GUIDE

by R. H. Warring £1.30

BEGINNER'S GUIDE TO PRACTICAL

ELECTRONICS by R. H. Warring £1.40

PRACTICAL SOLID-STATE PRINCIPLES

& PROJECTS by K. W. Sessions £1.25

SERVICING TRANSISTOR RADIO

RECEIVERS by F. R. Pettit 80p

ELECTRONIC PUZZLES & GAMES

by M. Mandl £1.25

104 EASY PROJECTS FOR THE

ELECTRONICS GADGETEER

by R. M. Brown £1.25

WORLD RADIO & TV HANDBOOK 1973

£3.12

RADIO HANDBOOK

by W. I. Orr £7.79

TRANSISTOR AUDIO & RADIO CIRCUITS

by MULLARD £1.95

TRANSISTOR CIRCUIT GUIDEBOOK

by B. Wels £1.30

HOW TO READ ELECTRONIC CIRCUIT

DIAGRAMS by R. M. Brown £1.40

ALL PRICES INCLUDE POSTAGE

We have the Finest Selection of English and American Radio Books in the Country

19-21 PRAED STREET (Dept RC) LONDON W2 1NP

Telephone 01-723 4185

Give us six months, and we'll turn your hobby into a career.

You have a hobby for a very good reason. It gives you a lot of pleasure.

So if you can find a job that involves your hobby, chances are you'll enjoy your work more, and you'll do better work.

Now CDI can help you find such a job. A job where you'll be responsible for the maintenance of a computer installation. A job that pays well too. If you're interested in mechanics or electronics (without necessarily being a

mathematical genius), have a clear, logical mind and a will to work, then we can train you to be a Computer Engineer inside six months.

So give us a call. CDI. We're the Training Division of one of the world's largest computer manufacturers. And we have the experience to know if you can make it. A ten minute talk with us, and you could be on the way to spending the rest of your life with your hobby.

Ring

01-637 2171

between 9 a.m. and 9 p.m. and ask for Mr. RYAN

It's quicker and easier to phone, but if you prefer, send this coupon to: Control Data Institute, Wells House, 77 Wells Street, London, W.1.

Please give me further information.

Name _____

Address _____

Age _____

Phone _____

RC7

CONTROL DATA
INSTITUTE

CONTROL DATA
LIMITED

The Training Division of one of the world's
largest Computer manufacturers.

RADIO & ELECTRONICS CONSTRUCTOR

DENCO (CLACTON) LIMITED

355-7-9 OLD ROAD, CLACTON-ON-SEA, ESSEX

Our components are chosen by Technical Authors and Constructors throughout the World for their performance and reliability, every coil being inspected twice plus a final test and near spot-on alignment as a final check.

Our General Catalogue showing full product range	20p
DTB4 Transistor & Valve circuitry for D.P. Coils	20p
DTB9 Valve Type Coil Pack Application circuitry	20p
MD.1 Decoder Circuitry for Stereo Reception	21p

All post paid, but please enclose S.A.E. with all other requests in the interests of retaining lowest possible prices to actual consumers

G & H ELECTRONICS

14 Sunny Hill Road, London S.W. 16.

141 Crofton Lane, Orpington, Kent. Tel: Orpington 31138

K.B. Record Player Cabinets, 4 col. 2 types, new £3 ea. Complete kit for above £16. p.p. 50p.
 K.B. Deluxe Stereo Cabinets £2.00 ea. Deluxe chrome knobs, set of 4 48p. Mains/battery radios, new, £7.50 ea.
 K.B. and R.G.D. Transistor Radio Cabinets, 10 types available, various colours and sizes, new and boxed 25p ea. Set of Dial knobs for above 12p per set.
 Attractive Mains Radio Cabinets, choice of 3 types, colour cream or brown, £1 ea. Knobs if required, 12p per set. p.p. 15p.

Full range of Radio & TV Components

	p.p.	
Elect Cond. from	10p	Volume controls dual:
Bias Cond. from	4p	ganged, less switch
Resistors from	1p	with switch
T.V. Droppers from	20p	Chrome handles 10"
Valve holders	5p	Blue PVC chrome
Valves from	25p	with clips 5"
Ferrite rods	5p	Black 10", plastic
Complete with coils	30p	handles
Speaker Transformer	25p	Polished wood table
Main trans. from	£1.50	ends, per set
Chokes, 10H 150MA	50p	Deluxe steel Legs,
Var. Cond.	35p	10", black with
V.H.F. tuners	£1.50	black chrome feet.
T.V. tuners	£2.00	Set of 4
Volume controls,		Brass hinges, each
less switch	10p	Piano hinges, each
with switch	15p	P & P on above 10p each

Solo Soldering Gun, self-feed type, with 2 oz reel of solder, in case, 110V or 6V Wkg. 60p, P & P 25p

ALL COMPONENTS DESPATCHED WITHIN 24 HOURS

VISIT LONDON'S LIGHTHOUSE

*our lighthouse keeper
wants to meet you!*

Jim Roche has been Imhofs Eddystone lighthouse keeper for a good few years now - so who better than he to guide you into the right channel, for an Eddystone communications receiver:

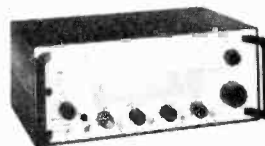

Model 1001 - general-purpose receiver with reception facilities for CW, MCW, AM and SSB. Provision for crystal control on 10 channels.

EC10 Mk II still 'Top of the Pops' in the modest price range of communication receivers. Embodies features usually only found in the more expensive designs.



IMHOFS

**112-116 New Oxford Street
London WC1A 1HJ
telephone 01-636 7878**

R81

In addition to telling you about our Catalogue each month we would like to bring to your notice one or two items which we believe are **UNIQUE TO HOME RADIO (Components) LTD.**

To start off here is the

'ERSA' SPRINT IRON

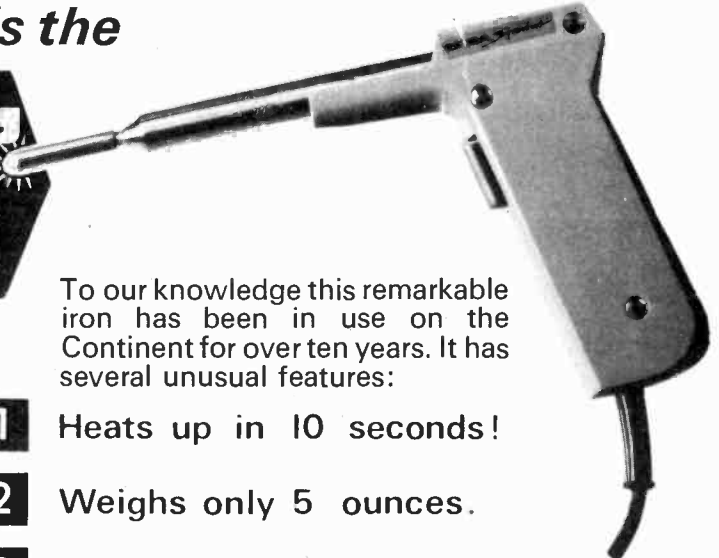

To our knowledge this remarkable iron has been in use on the Continent for over ten years. It has several unusual features:

We carry complete spares, right down to the last nut and bolt, even spare mains leads. Our price for this desirable object is only **£3.98 plus 18 pence p & p.** Essentially this is a tool for the field service engineer or the handyman and experimenter wishing to make a few quick joints. A constructor building something with a large number of joints might find a conventional iron quicker.

- 1** Heats up in 10 seconds!
- 2** Weighs only 5 ounces.
- 3** Parts can be changed in seconds.
- 4** Can be used on anything from a transistor upwards.

(A friend of ours used one to repair his water tank. We think this is asking too much!)



The **"ERSA" SPRINT IRON** is just one of the many exciting things to be found in the famous 250-page Home Radio Components Catalogue. No less than 6,785 electronic components are listed and indexed, and 1,750 items are illustrated. A free bookmark with a useful list of technical abbreviations is included. The catalogue costs 55p plus 22p post and packing. Every copy contains 10 vouchers each worth 5 pence when used as directed. Regularly updated price lists are supplied to you free.



Send now for catalogue

Please write your Name and Address in block capitals

NAME

ADDRESS

.....

.....

HOME RADIO (Components) LTD., Dept. RC,
234-240 London Road, Mitcham, Surrey CR4 3HD

Regd. No.
912966 London



POST THIS COUPON
with cheque or P.O. for 77p.

The price of 77p applies only to catalogues purchased by customers in the U.K. and to BFPO addresses.

RADIO & ELECTRONICS CONSTRUCTOR

JUNE 1973

CONTENTS

Vol. 26 No. 11

Published Monthly (1st of Month)
First Published 1947

Incorporating The Radio Amateur

Editorial and Advertising Offices
57 MAIDA VALE LONDON W9 1SN

Telephone Telegrams
01-286 6141 Databux, London

© *Data Publications Ltd.*, 1972. Contents may only be reproduced after obtaining prior permission from the Editor. Short abstracts or references are allowable provided acknowledgement of source is given.

Annual Subscription: £2.70 (U.S.A. and Canada \$7.00) including postage. Remittances should be made payable to "Data Publications Ltd". Overseas readers please pay by cheque or International Money Order.

Technical Queries. We regret that we are unable to answer queries other than those arising from articles appearing in this magazine nor can we advise on modifications to equipment described. We regret that such queries cannot be answered over the telephone; they must be submitted in writing and accompanied by a stamped addressed envelope for reply.

Correspondence should be addressed to the Editor, Advertising Manager, Subscription Manager or the Publishers as appropriate.

Opinions expressed by contributors are not necessarily those of the Editor or proprietors.

Production.—Web Offset.

SERVICING THE TRANSISTOR PORTABLE – Part 1, by Vivian Capel	676
NEWS AND COMMENT	680
AUTOMATIC LAMP SWITCH (Suggested Circuit 271) by G. A. French	682
RECENT PUBLICATIONS	684
THE 'SLIDING JUNIOR' AMPLIFIER by Sir Douglas Hall, K.C.M.G., M.A. (Oxon)	685
COMBINATION LOCK by J. D. Parkinson	691
NEW PRODUCTS	693
SHORT WAVE NEWS by Frank A. Baldwin	694
SILICON NETWORK POCKET PORTABLE by F. G. Rayer, Assoc. I.E.R.E., G30GR	696
FINAL NOTES ON CYCLOPS by L. C. Galitz	701
FINDING BIAS RESISTANCE VALUES by J. R. Davies	705
OSCAR – PROGRESS REPORT by Arthur C. Gee, G2UK	709
ASTABLE MULTIVIBRATORS – Part 1 by A. Foord	710
IN YO'UR WORKSHOP – Transistor Lead-out Identifier	713
RADIO TOPICS by Recorder	720
CONSTRUCTOR'S DATA SHEET No. 75 (Resonant Frequencies – III)	iii

Published in Great Britain by the Proprietors and Publishers, Data Publications Ltd, 57 Maida Vale, London, W9 1SN

The *Radio & Electronics Constructor* is printed by Carlisle Web Offset.

JULY ISSUE WILL BE PUBLISHED ON JULY 1st

SERVICING THE TRANSISTOR PORTABLE

Part 1

by

Vivian-Capel

Professional tips on tracing faults in completely dead receivers and in receivers with distorted output are given in this article. A concluding article to be published next month, will deal with low sensitivity and the procedure of alignment.

THE READER HARDLY NEEDS TO BE TOLD THAT THE portable medium and long wave transistor radio is now part of the present-day scene. Unfortunately, these radios do not always remain serviceable and, for the radio service engineer, this means a continuous crop of faulty units brought in what seems a never-ending trail into the workshop.

Many dealer's service departments refuse to repair these sets because the process is just not economic. Service information is often sparse and spares difficult to obtain, and under these conditions labour costs can almost equal the price of a new set, especially the cheaper imported variety. Other dealers accept them but with a time limitation, so that if the engineer cannot find the fault in, say, a quarter of an hour, the repair is regarded as uneconomic. An exception is the better-class more expensive radio with a well-known brand-name, for which spares and technical information are available.

TRADE TIPS

The overall result of the situation is a large number of faulty radios for which the owners are not able to obtain service. For the amateur who makes radio his hobby offering a repair service could provide an interesting and profitable side-line, because he does not have the overheads and labour-cost problems of the professional service department. Service engineers who do handle these receivers usually have a time-saving routine of checks and tests based on experience of the most likely faults, and which will show up 90% of them. In these two articles the author will describe some of the things the professional engineer looks for and pass on some trade tips. A number of common faults are illustrated in Fig. 1.

A frequent fault is given when the receiver is completely dead. In theory a large number of things could be responsible, but in practice they can be narrowed down to a few, so these can be checked first. Often, batteries are left in the set until they leak and cause corrosion of the springs and terminals holding them. While the

owner may replace the batteries the corrosion remains and prevents a good contact with the new batteries. It is also common for the set to be left switched on, since the switch on many sets does not give a positive click, and so although the owner may say that the batteries are new they can in fact be flat. It is not uncommon for a set to be brought into the workshop with some other faults, but still switched on, so that if the batteries were not the cause of the original trouble they will be dead by the time the set is put on the bench for repair.

The first test then is always to measure the battery voltage, not directly across the battery but across the wires that go from the battery to the set, since this will check the battery contacts as well as the battery itself. Furthermore, this test should be carried out with the set switched on, because some exhausted batteries give an almost full reading off-load, whilst their voltage drops dramatically when the load is connected.

If the battery is a few volts down one may still expect the set to work although, perhaps, with distortion and low volume. This is not always the case, however, as some oscillators will refuse to work below a certain voltage, hence preventing the set from reproducing signals. Anything below three-quarters of correct battery voltage should be suspect.

Another very common cause of a dead set is the on-off switch. Usually these are an integral part of an edge-type volume-control, and are impossible to repair economically. If the switch is open-circuit, then a complete new control will be required. Fortunately, these are in most cases a standard value at $5k\Omega$, but the physical size varies. If the replacement is too big it will jam in the case-slot, and if it is too small it cannot be reached by the user. Some component firms make two or three different sizes and styles but unfortunately there are other sizes in use for which replacements are not obtainable. The problem can and has been overcome on a number of occasions by breaking up the old control to obtain the plastic wheel, selecting a replacement that is smaller, then cutting a hole in the old wheel with a hot pin just big enough to take the new control. Finally, the new control is fixed in the old wheel with

RADIO & ELECTRONICS CONSTRUCTOR

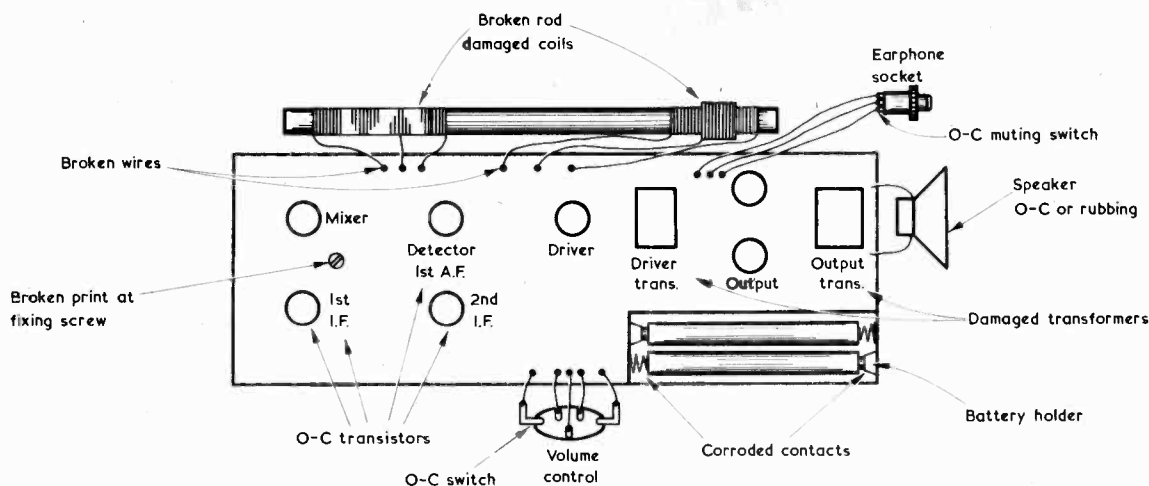

Fig. 1. The most common faults in the average medium and long wave transistor radio

one or two dabs with a hot iron to weld the plastic together. This procedure takes a little time, but it does get over the difficulty of providing a new volume control.

The disposition of the control and switch contacts may not line up with those of the old one in the printed-circuit panel, but this can usually be overcome by bending some of the contacts and soldering copper wire to those that do not reach. Some controls have the switch mounted externally to the control, in which case a repair can often be effected by simply adjusting the contacts.

ISOLATION

If battery, leads and switch are in order one must look deeper. Now it is best to isolate the end of the set, r.f. or audio, in which the trouble lies. First, check with the meter to see if there is a voltage between the volume-control slider and chassis. If not or if it is low, it is safe to make a disturbance test using the testmeter switched to an ohms range. By scratching the meter probe on the slider terminal, a spiky audio waveform will be injected into the audio circuits which should produce a pronounced crackling in the loudspeaker. If it does not, then the audio circuits are at fault.

A large number of troubles with transistor radios are due to falls or physical shock. There are several areas where this is most likely to occur. A blow or undue pressure on the volume control can cause a fracture of the printed board around the area where it is mounted. Any crack in the board will usually mean a crack in the printed circuit conductor as well. Another common position for board fracture is around the holes where the board is fixed to the case. A fall will almost certainly produce a fracture here. If there is no printed conductor in the vicinity, no effect will be produced, but if there is then this too will most likely be broken. It must be stressed that these print faults are not easily visible, but the board fractures can quite readily be observed. In consequence, always look at the board for fracture first.

If, as occurs with some models, the speaker is fixed to the board instead of in the case it, too, can cause a

fracture in a fall, whereupon a look around the fixing holes is well worth-while.

Another common damage effect is that suffered by a.f. output and driver transformers. These are fixed to the board by their terminal pins, to which are soldered the fine lead-out wires from the windings. A shock, as occasioned by a fall, will wrench the transformer from its pins, thus breaking the lead-out wires. A quick look will often not reveal that anything is wrong, because the transformer is still sitting more or less in place on the board, but a closer examination will show the broken lead-out wires.

So common are these troubles that some engineers make a physical examination of the areas mentioned for fractures, and also the transformers for broken wires, as well as the ferrite aerial coil leads – another prolific source of trouble – before even showing the meter to the set or making any electrical tests at all. They are often rewarded by spotting the trouble within a few minutes.

THE LOUDSPEAKER

If there is no crackling when the test on the volume control is made, it is worth checking the loudspeaker. The high impedance models (around 30Ω) used in many transistor sets use very fine wire for the speech coil, and these often go open-circuit. The earphone socket is another possibility as these include a speaker muting-switch which can be damaged by clumsy insertion of the earphone plug. Check also the collector voltage of the driver transistor, this comes via the primary of the driver transformer which can go open-circuit.

If the audio stages are lively, then operation of the waverange switch will give a clue as to whether the trouble is in the i.f. stages, or the mixer and r.f. stages. A healthy crackle will in most cases eliminate the i.f. stages. If a check has not already been made on the ferrite aerial coil wires these are the next suspects. A broken wire can give rise to different symptoms, depending on the circuit which is affected. A common wire for both long wave and medium wave coils or a common coupling coil can mean complete loss of signals, otherwise only one waveband is out. A rather

puzzling effect is that of breakthrough from one band into the other as occurs if, for instance, the Radio 2 programme on 1,500 metres comes through on Radio 4. This is not a tuning or oscillator fault as may be imagined, but usually an open-circuit aerial coil.

Look out for vertically mounted components such as capacitors that may have become displaced, being forced over so that the wire has pulled away from the print. Components near the battery compartment are particularly prone to this sort of trouble, suffering from the attempts of ham-handed owners to replace the batteries!

TESTMETER CHECKS

These few checks plus a visual examination take but a few minutes, and if not actually revealing the fault (which in many cases they will) do at least narrow down the search to the particular section concerned. The next step is to check the transistors and print within the suspected section, as these two are the next most likely to cause trouble. Print faults in this case may not be accompanied by a board fracture which makes them easy to detect, but may consist of tiny hair-line cracks almost invisible to the naked eye. The meter will now be needed to check voltages.

If service data is not to hand, which in most cases it will not be, there will be no voltage figures to compare. Furthermore there is often confusion as to whether the chassis is common to the positive or negative supply lines, and whether therefore the transistor collectors are high or low voltage to earth. The best course is to ignore the chassis connection and clip the meter positive lead to battery positive. Most transistors used at present in radios brought in for service are still p.n.p. types, so this will enable the normal arrangement of voltages, high at the collector and low on the base and emitter, to be measured without mentally inverting. If the radio is known to have n.p.n. transistors, or if the first few checks show that this must obviously be the case, then the testmeter negative clip is connected to battery negative and voltages measured by way of the positive meter lead.

Collector voltages vary according to the transistor function and circuit, so without service data not much can be deduced from precise readings. However, half to three-quarters of the battery voltage is the usual range encountered, except for first stage audio transistors that are directly coupled to the next stage; here the readings will be very low. The main object of taking the collector reading is really to see if a voltage is there or not. If not then the intervening path to the supply line is broken somewhere.

The base and emitter voltage measurements are rather more helpful. Assuming germanium p.n.p. transistors, the base must be slightly more negative than the emitter, so a difference of 0.1 to 0.2 volt should be observed, otherwise the transistor will be cut off. With silicon transistors the base-emitter voltage is about 0.6 volt. A high base voltage could be an internal leak to collector, or an open-circuit bottom potential divider bias resistor. A low base voltage could indicate an open-circuit top divider resistor. No emitter voltage is the result of an open-circuit transistor unless, of course, the emitter has no series resistor. If there is emitter and base voltage and low collector voltage there may be excessive current due to an internal leakage. All voltages the same indicates a short-circuit transistor.

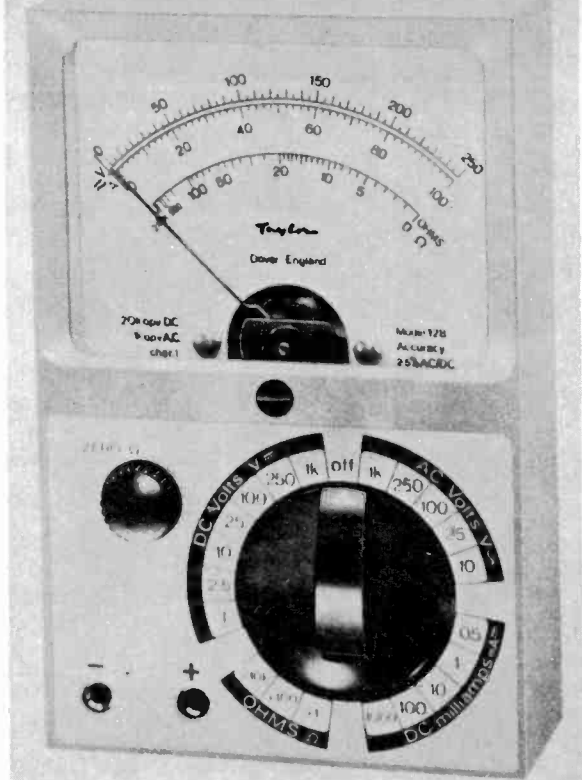

A good testmeter is invaluable in the service workshop, particularly for tracing the more complex faults. This instrument, the Model 128 manufactured by Taylor Electrical Instruments, Ltd., offers a large number of ranges and has a d.c. sensitivity of 20,000 ohms per volt

Emitter and base voltages in receivers with p.n.p. transistors will generally be about 0.5 to 1 volt as measured from the positive line, although the voltage may vary with some circuits. There may also be a series resistor between the main positive line and battery positive which would increase all such readings.

If a transistor is suspected, it is not always necessary to remove it in order to try a replacement unless the original has a leak. The new transistor can be soldered temporarily across the existing one and it will work, the old transistor having little, if any, effect. This saves time and possible damage through heat to the old transistor if it proves to be serviceable after all. If the transistor is proved faulty, then it can be removed and the replacement fitted properly.

Many imported sets use transistors with type numbers that no-one seems to have heard of, many even without type numbers at all. Fortunately transistors, unlike valves, have a high degree of compatibility, so one can usually fit as replacement any transistor that is of the same polarity and in the same class (i.e. mixer, r.f., a.f., or output). With cheap radios minor performance differences are unimportant; in fact the results with the replacement transistor may even be better than with the original! The output stage is the only one where some care will be needed in choosing a replacement, and alteration of the base forward bias may be needed. After replacing the output transistors with a pair of another type, check that the quiescent current is reasonable for the type of set, 9 to 18mA being usual, and that the distortion level is acceptable.

Incorrect transistor voltages may be due to print faults, but often the faults are such that little or no

voltage discrepancies result. Finding these faults can be tedious and time-consuming, especially without a circuit diagram. One method of dealing with this type of trouble is to first locate the stage or stages wherein the fault lies, as previously shown, and then run the soldering iron briefly over all the printed strips in that area, melting the solder along the print and also where components are connected in. Take care not to inadvertently bridge adjacent strips with excess solder. It is often found after this operation, which should only take a few minutes, that the fault has been cured.

DISTORTION

Another very common complaint is distortion. In by far the majority of cases the trouble lies in the output stage, so diagnosis should be straightforward. Make sure that the battery voltage is well up though first.

A frequent source of trouble is failure of one half of the push-pull output pair. If of the series configuration (identified by the absence of an output transformer) take voltage readings to find if the collector of the bottom transistor and the emitter of the top one are at about half the battery voltage. See Fig. 2 (a). If there is an appreciable difference, one transistor is most likely either open-circuit or short-circuit, depending on which way the reading is, high or low. The quickest and easiest diagnosis in this case is to disconnect the collector of each transistor and solder a new pair across. Before doing so, though, one may check the base-bias resistors and take another voltage measurement with the speaker disconnected. The capacitor feeding the speaker may be leaking, thus causing an abnormal reading. In this case disconnection of the capacitor will return the reading to normal.

If the output stage is of the transformer type, as in Fig. 2 (b), voltage readings will not be of much help. Defective transistors will not have a great effect on the voltage because of the low transformer winding resistances in series with them. Voltage should still be measured, of course, to make sure that bias is present and that the output transformer windings are continuous. One way of testing whether one half of the stage is working is to short-circuit the base to the emitter of the appropriate transistor. This removes the forward bias and of course the signal. If the stage section is working there will be a drop in volume and further deterioration of quality, or if the other section is not working, complete loss of signals; if there is little difference, then the section with the short-circuit is not working. This test is not always conclusive because, with some circuits having a low d.c. resistance driver transformer, the bias will be removed from the other transistor as well. However, it is a quick test worth a try.

If one transistor is found to be defective, discretion can be used as to whether to replace the other one as well. Unless one is going to replace with a matched pair it is not usually necessary to change them both, as there is just as likely to be a wide production deviation between two new ones as between the remaining old one and a single new one. If transistors of a different type are to be used, then of course the pair must be changed.

Another cause of distortion is the loudspeaker itself. The trouble is due to the speech-coil rubbing against the poles of the magnet. The magnet is easily displaced, and a fall can be responsible. This fault is not always easy to identify because the effect can be very similar to output stage distortion.

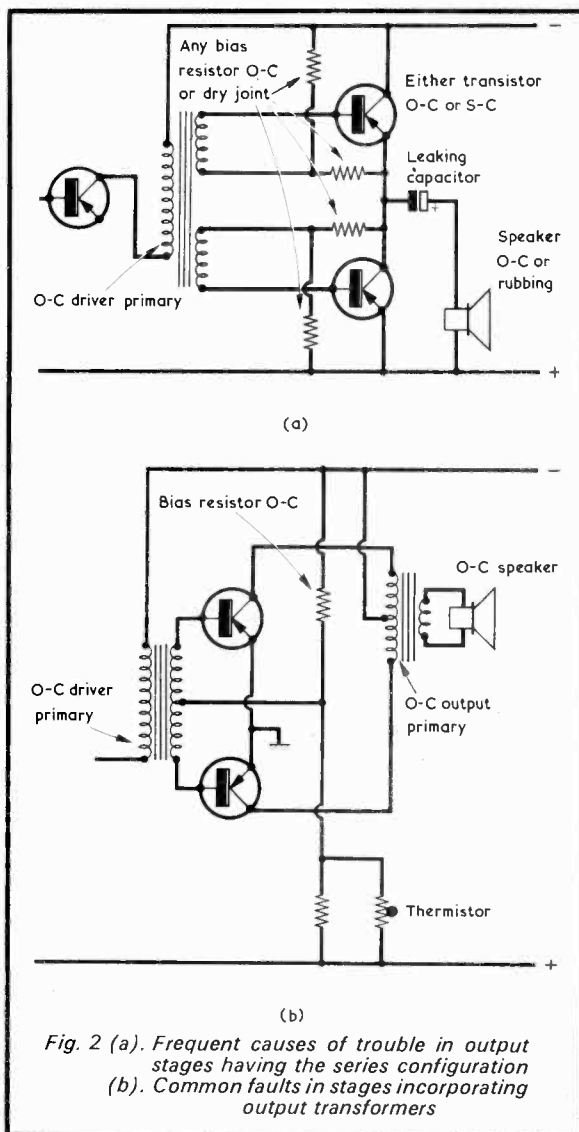

Fig. 2 (a). Frequent causes of trouble in output stages having the series configuration
(b). Common faults in stages incorporating output transformers

One tip to distinguish between them is to listen at both low and high volume levels. Speaker distortion is usually worse at lower levels because the higher levels mask the rubbing sounds, whereas output-stage distortion is worse at the higher levels. There can be exceptions, but this rule applies in the majority of cases.

Often, the rubbing can be felt by gently pushing the cone in and out with the fingers. Hooking up another speaker is the most decisive test. Impedance is not very critical, and a speaker of slightly lower impedance can be used for a brief period, if the volume is kept moderate without damage to the output stage. Volume will be lower in this case but it will be sufficient to hear whether the distortion is still present.

So then, battery voltage low, one half of the push-pull output pair defective, bias incorrect, or speaker fault, are the four most usual causes of distortion. There are others, but these will have to be found by normal fault-finding techniques.

(To be concluded)

NEWS . . . AND

EMI LAUNCHES ITS FIRST STEREO HI-FI AMPLIFIER AND QUADRAPHONIC DECODER

The introduction of a medium-priced solid-state stereo amplifier and a quadraphonic decoder marks EMI's intention to increase its stake in the mushrooming hi-fi hardware market, after many years as a manufacturer of high quality loudspeaker systems. Both EMI developments, the new 15 watts per channel amplifier and the decoder, which utilises the popular SQ Quad technique, were launched recently at a trade preview by EMI Pathe, a division of EMI Sound & Vision Equipment Ltd., Hayes, Middlesex.

Stereo Amplifier

Known as the EMI 1515, the versatile teak-veneered amplifier is recommended to sell at £46.50 retail, including VAT, and offers a specification and performance above most equipment in its price range. It is designed to reproduce sound, in high quality mono or stereo form, originating from as many as six different sources. These include magnetic and ceramic disc turntables, magnetic tape decks, stereo radio tuner, microphones, and equipment such as electric musical instruments. Separate plug-in facilities are provided for each of these inputs.

A special feature of the 1515 unit is its ability to provide the electrical supply for a complete unit stereo system. Equipment such as disc or tape decks and tuner can be plugged into two switched mains sockets at the rear, thus eliminating the untidy clutter of wiring to the mains normally associated with unit stereo.

For personal listening, the amplifier incorporates a socket for stereo headphones. In this mode, the sound is automatically cut from the main loudspeakers and reduced to a low level.

Quadraphonic Decoder

Designed to equip conventional stereo systems with the increased capability of playing the new SQ four-channel records, the EMI quadraphonic decoder's function is to separate the four channels of sound contained on the two-channel SQ Quad discs produced by EMI Records and other leading companies.

The photograph shows the new EMI 1515 stereo amplifier and the smaller, EMI SQ 1500 quadraphonic decoder unit pictured with two EMI LE2 15-watt loudspeakers to form a complete "add-on" package for converting a suitable existing stereo system for SQ quadraphonic reproduction



WIPING CLOTHS FOR DELICATE WORK

For cleaning delicate equipment in industry and commerce Clean Tread Services Limited have introduced special wiping cloths. Made of a non-woven fabric, they are lint-resistant with a limited life.

They are particularly suitable for computer rooms, telephone exchanges, electronic equipment, etc. They are, of course, equally suitable for light dusting of desks, tables, etc.

Yellow in colour, cloths have an overall controlled impregnation by a special dust-attracting chemical - thus ensuring the removal of dirt and dust without the necessity for heavy pressure. They have an average life of a week.

Clean Tread Services supply 16" x 16" cloths in boxes of 50, at a price of 5p per cloth.



COMMENT

BURGLAR ALARMS

Following the success of the "Household Burglar Alarm" featured in our last issue, we can now give some news of a relatively highly sophisticated, minicomputer-controlled, security network which has been put into operation by a major bank in Pittsburgh, Pennsylvania, to watch windows, doors and bank vaults, and to call the police if the bank is robbed. In fact, officials of the Mellon Bank and Trust Co. claim their new automatic security system has already been instrumental in the capture of one would-be bank robber at one of their branches. The bandit was arrested less than two minutes after police headquarters received a teletype alert printed out on the command of a Computer Automation Alpha 16 minicomputer incorporated in the bank's new Diebold DGM-320 Security System.

This police alarm was an automatic function of the system, which continuously monitors security sensitive areas in the bank's headquarters and 22 area branch offices, through electronic sensors plugged into a private data communications network, as well as a closed-circuit television surveillance system.

It is claimed to be the most comprehensive security installation ever developed for a financial institution.

As a tailpiece to this news item, we read an amusing anecdote in a recent issue of *Mobile News*, the journal of the Amateur Radio Mobile Society. It appears that one of their members was tuning up his mobile rig when he noticed that the local burglar alarms were ringing and that they came on and off as he tuned. "We beat it quick!" was the comment.

MAINS-BATTERY PORTABLE CASSETTE RECORDER



A new mains/battery portable cassette recorder from ITT offers features which, say the company, have hitherto only been found on models selling at much more than the Studio 60's recommended £38.95.

The Studio 60 has been designed to meet the criteria of the enthusiast who has cut his teeth on a fairly basic model and now demands rather more sophistication in terms of performance, design and appearance.

The machine is housed in a smart matt black case with brushed aluminium control panel, speaker grille and fold-away carrying handle. It weighs just over 5 lbs.

IN BRIEF

● Her Majesty the Queen has been graciously pleased to confer Her Award To Industry in 1973 upon English Electric Valve Company in recognition of outstanding achievement in technological innovation in respect of Ceramic Hydrogen Thyatrons.

It was in 1968 that EEV first received the Queen's Award To Industry for technological achievement in respect of the Image Isocon "see in the dark" TV camera tube.

● The British Amateur Radio Teleprinter Group, following the success of their first Convention last year, are holding a second one at the Meopham Village Hall, Meopham, Near Gravesend, Kent on Saturday 30th June, from 11.0 a.m. to 6.0 p.m.

There will be lectures, demonstrations of both unusual and popular teleprinter machines, a live amateur station, G4ATG, also trade exhibitors etc.

For further information write to G. Shirville, G3VZV, 2 Orchard Close, Toddington, Dunstable, Bedfordshire, tel: Toddington 2470.

● The 50th anniversary of official German broadcasting will be celebrated within the framework of the International Radio and TV Exhibition to be held from 31st August to 9th September in Berlin.

● The Hon. Treasurer of the Radio Society of Great Britain has announced that subscriptions to the R.S.G.B. will be increased to £5 per annum, for Corporate members, as from 1st July 1973. Unfortunately for members, V.A.T. is payable on subscriptions so the total amount is £5.50.

The Society is not however increasing the subscription rate of the younger members and the V.A.T. on those subscriptions is being borne by the Society.

● An entirely new concept of naval communications is the basis of a multi-million pound contract placed with Marconi Communications Systems Ltd.

The new system, designated ICS 3, will give the Royal Navy the most sophisticated and comprehensive communications system in the world.



"I'll be glad when my electric razor is repaired!"

AUTOMATIC LAMP SWITCH

by G. A. FRENCH

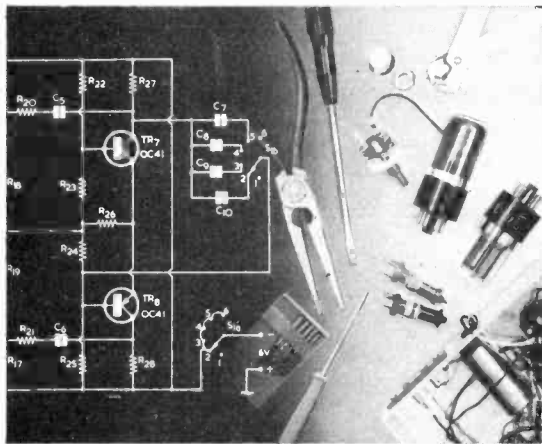

REGULAR READERS WILL RECALL that last month's article in the 'Suggested Circuit' series described a triac circuit by means of which a 100 watt domestic light bulb could be switched on and off by a low control current which was completely isolated from the mains supply. The control current could, indeed, be obtained from such sources as the outputs of t.t.l. logic gates. The article also discussed triac operation and pointed out that, in a simple application where a triac functions effectively as an on-off switch in an a.c. circuit, the minimum gate triggering current is different for alternate half-cycles of the applied alternating voltage. The gate current has to be greater than that required by the triac on the half-cycles when it is less sensitive if reliable switching is to occur. Ideally the gate current, in taking the triac from the off to the on condition, should increase abruptly from zero or a very low value to the full triggering level required.

LIGHT CONTROL

The circuit described in the present article also incorporates a triac which controls a 100 watt domestic light bulb. In this instance the triac is operated by a photoconductive cell which causes the triac to become conductive when ambient light level outside a house or building falls, and to become non-conductive when the ambient light level rises again. The circuit can, in consequence, be employed for automatic switching of, say, a porch or garage lamp, the lamp being switched on when night falls and switched off the following morning. Readers may be able to visualise other applications. Triac operation in the unit to be described can be overridden by two

switches which are incorporated in the circuit, with the result that the device may be used merely to turn on the lamp as ambient light falls, or to turn it off as ambient light increases.

In the preceding article, a triac was controlled by a circuit incorporating a photoconductive cell type ORP12, and this circuit demonstrated that the triac could be held in a state midway between non-conduction and full conduction at intermediate levels of illumination of the cell. It is obvious that a circuit of similar type would not meet present requirements since, as ambient light level gradually decreased during the evening, or gradually increased at dawn, the controlled bulb would pass through a period in which it was not fully illuminated. What is required is a trigger circuit which changes virtually instantaneously from the trigger-off to the trigger-on condition, and from the trigger-on to the trigger-off condition.

It is also necessary for the triac trigger circuit to have either a long time constant of operation or to have marked hysteresis. Either of these will obviate the condition where, as the ambient light outside the house or building is around triggering level, the triac is turned continually on and off by such things as passing clouds. Of the two requirements, it is easier to arrange for hysteresis rather than for a long time constant of operation and it is, in fact, a relatively simple matter to design a trigger circuit which turns on the triac at an ambient light level which is significantly lower than the subsequent ambient light level which turns it off again.

The circuit of the automatic lamp switch is given in Fig. 1. In this diagram S1 is the main on-off switch for the unit and it applies the a.c.

mains to the triac and the controlled 100 watt bulb in series. S2 short-circuits the triac for occasions when automatic control is not required. When S2 is closed, S1 switches the 100 watt bulb on and off in normal manner. The triac is an R.C.A. device type 40430 (available from Electrovalue Ltd.) and its Main Terminal 2 connects to the controlled bulb, its Main Terminal 1 to the neutral side of the mains supply, and its gate to the source of triggering current. The triac becomes conductive when a sufficiently high triggering current, of either polarity, is allowed to flow between its gate and Main Terminal 1.

Closing S1 also applies the mains supply to the primary of mains transformer T1. The 8 volt secondary of this transformer couples to the bridge rectifier given by D1 to D4, and a rectified voltage of around 10 volts appears across reservoir capacitor C1. The positive side of this d.c. supply is common with Main Terminal 1 of the triac.

The photoconductive cell which senses changes in ambient light level is the ORP12 which is connected in the PC1 position. An ORP12 exhibits a resistance in excess of several megohms in the fully dark condition and a resistance of 300Ω or less when fully illuminated. It is connected in series with R1 and VR1, the base of TR1 coupling to the junction of these two resistors. Since the resistance of the photoconductive cell increases as its illumination decreases, a fall in ambient light level (assuming that VR1 slider is not at the extreme upper end of its track) causes the base of TR1 to go negative. R1 is a limiting resistor which limits possible dissipation in the photoconductive cell.

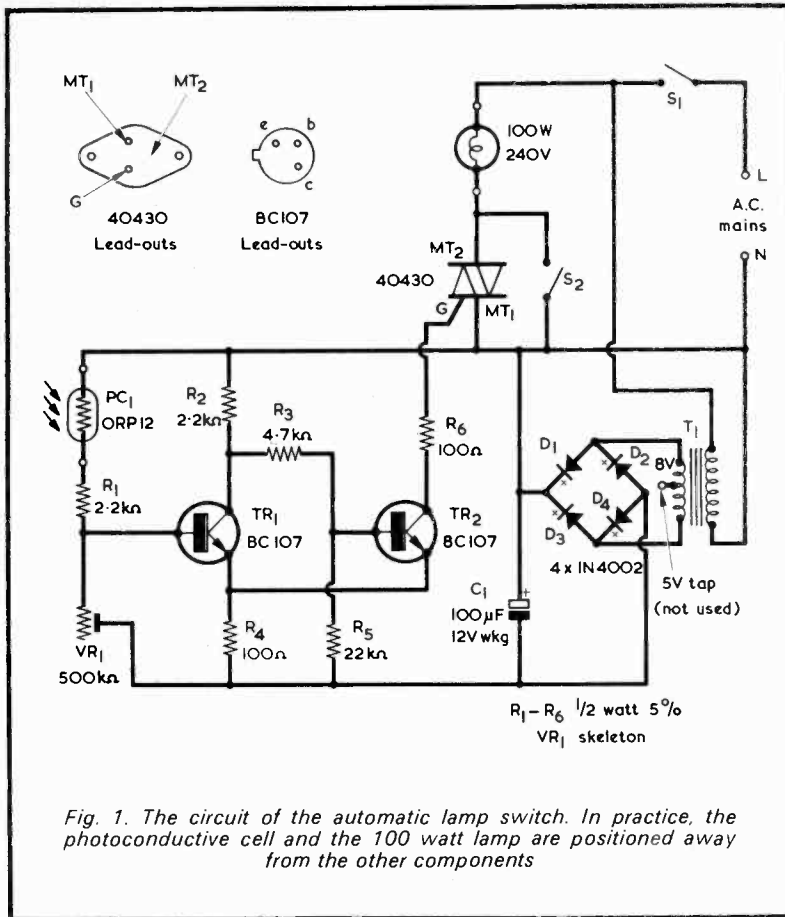

Fig. 1. The circuit of the automatic lamp switch. In practice, the photoconductive cell and the 100 watt lamp are positioned away from the other components

TR1 and TR2 are wired in a Schmitt trigger circuit. If, in this circuit, the base of TR1 is at the same potential as the negative 10 volt supply rail, this transistor is off and sufficient current flows through R2 and R3 to turn TR2 on. The emitter current in TR2 causes a voltage to be dropped across R4 and this voltage is applied to the emitter of TR1. If the base of TR1 is now caused to go positive this transistor will remain turned off until the base voltage reaches a level which is equal to the voltage dropped across R4 plus the normal base-emitter voltage drop for the transistor. TR1 now commences to pass current and, if the base voltage is taken slightly further positive, draws sufficient current through R2 to remove the base bias for TR2. TR2 cuts off, the voltage across R4 reduces, and TR1 becomes fully conductive.

If, next, the base voltage of TR1 is reduced, a level is reached where this transistor draws reduced current. A bias current now flows in TR2 base via R2 and R3, causing this transistor to conduct and to produce an increased voltage drop across R4, thereby biasing TR1 further towards cut-off. The circuit then reverts to its initial state, with TR1 off and TR2 turned on.

Because of the amplification offered by the two transistors and the regenerative couplings between them, the transitions from the first state to the second and from the second state to the first are very swift. Circuit operation here is comparable with the swift transitions of state in a multivibrator. Hysteresis, or 'backlash', is inevitable in a Schmitt trigger, and is demonstrated here by the fact that the positive voltage at TR1 base which is needed to turn this transistor on is higher than that needed to turn it off. In the present circuit, the values for R2 to R5 have been purposely selected to provide a high level of hysteresis; with the prototype TR1 base had to be raised to about 4 volts positive of the negative supply rail to turn it on, and then reduced to about 1 volt to turn it off again.

The triac is triggered on, and the controlled bulb is lit, when TR2 is conductive. The triac gate current then flows from the negative supply rail through R4, the transistor and R6. It follows that the triac is conductive when TR1 is off, as occurs when the base of TR1 has a low voltage. Since this low voltage is given when PC1 has a high resistance due to low ambient light level, the requisite chain of control

from decrease of ambient light level to switch-on of the bulb is achieved.

As will be noted, the Schmitt trigger gives the hysteresis and rapid switch-on and switch-off requirements for the triac which were mentioned earlier. An incidental advantage of the trigger circuit is that the amplification offered by the two transistors in it enables TR2 to pass a triac gate current of about 50mA whilst a base current of only some 50μA or less is needed by TR1 when this transistor becomes conductive.

The sensitivity of the unit is set up by means of pre-set potentiometer VR1. The circuit trips at lower ambient light levels as the resistance inserted by this potentiometer increases.

CONSTRUCTION

All the components in the unit are standard types. A retail source for the triac has already been given. In the prototype, this component was mounted on a flat heat sink about 1½ in. square. Transformer T1 was an 8 volt bell battery, of the type available from Woolworth's stores. However, the power supply section is not critical and any supply offering a reasonably smooth d.c. output at around 10 volts may be employed instead. Switches S1 and S2 can be standard wall-mounting on-off switches of the type normally employed for controlling domestic lamps. The controlled bulb can, if desired, have a rating lower than 100 watts. The photoconductive cell type ORP12 may be referred to in some sales literature as a 'light dependent resistor'.

The components, with the exception of PC1 and, of course, the controlled bulb, should be fitted in an enclosed case made of insulating material with S1 and S2 mounted on the outside. All the parts run cool and only a small amount of ventilation, if any, is required. Layout is unimportant. A hole in the case is required for adjusting VR1.

Both PC1 and the 100 watt bulb couple to the remainder of the circuit via 2-core wires. The bulb is mounted in its intended position, whilst the photoconductive cell is fitted at a point where it can monitor the ambient light outside the house or building. A simple method of carrying this out consists of fitting the cell in a round tube made of any convenient insulating material in the manner shown in Fig. 2. This tube can be positioned, with its open end pointing up at about 60° to the horizontal, at a convenient window. If the tube is mounted inside the window there is no need to provide weather-proofing, but it may be necessary to shield the open end of the tube from interior lighting. The tube should not, of course, be directed towards any street lamps or similar artificial sources of illumination. A lens is not required and should not be fitted to the tube.

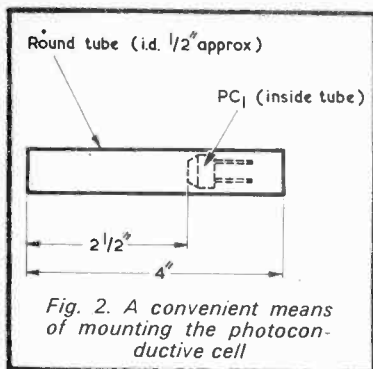

An interesting feature is that the overall circuit functions as a very high gain 'light amplifier', since quite small changes in light intensity, within the Schmitt trigger hysteresis range, at the photoconductive cell cause a very large change in light intensity at the controlled bulb. In consequence it is possible for the system to become

unstable if some of the light from the controlled bulb is allowed to fall on the photoconductive cell. The latter does not offer an instantaneous change in resistance when the light intensity by which it is illuminated varies, and the result of this 'feedback' may be a continual flickering on and off of the controlled bulb. The circumstances needed for this condition to appear are, admittedly, rather critical, but the point should be mentioned in case it is encountered by the constructor. The effect cannot occur if the tube in which the photoconductive cell is fitted is directed well away from the controlled bulb.

A further important point is that all the wiring and components in the circuit, including the leads to the photoconductive cell and to the controlled bulb, are at mains potential. *The control circuit and the photoconductive cell must be mounted in fully insulated housings and all precautions against shock must be carefully observed.*

After the unit has been completed it may be checked out by directing the photoconductive cell, in its tube, at different levels of light and ensuring that the controlled bulb turns on and off as desired. Sensitivity can be varied by adjusting VR1. It should be noted that the photoconductive cell loses control if the slider of VR1 is fully at or very near the upper end of its track, since TR1 is then held permanently in the off condition. *Remember, when handling the photoconductive cell, that the leads which connect to it are at mains potential.*

The photoconductive cell may then be mounted in its final position. When the outside ambient light level is low, i.e. considerably less than that given in the late morning and early afternoon VR1 is set up. It should be initially adjusted to insert maximum resistance into circuit, after which the resistance, it inserts is slowly reduced until a setting is reached at which the controlled bulb turns on. VR1 is then left at that setting. ■

RECENT PUBLICATIONS



MAKING AND USING OSCILLATORS. By W. Oliver.

120 pages, 135 x 215mm. (5 1/4 x 8 1/2 in.). Published by W. Foulsham & Co. Ltd. Price £2.00.

It is, probably, only when one chooses to reflect on the matter that one realises what an exceptionally wide variety of oscillators is employed in electronics at the present time. Apart from standard LC feedback oscillators there are crystal oscillators, RC oscillators and oscillators which function due to a particular facet of semiconductor performance. This book deals with many of the oscillator circuits currently in use.

The first chapter in the book explains how oscillators work. The second deals with the classification of oscillators, giving circuits which include the Hartley oscillator, the phase shift oscillator and the multivibrator. The next chapter discusses crystal-controlled oscillators, and is followed by a chapter on variable frequency oscillators as would be employed in transmitters. Two chapters on receiver and audio oscillators appear next, to be succeeded by chapters describing oscillators for test equipment and for electronic musical instruments. The remaining chapters in the book are devoted to specialised oscillators, including the neon relaxation and tunnel diode oscillators; valves, semiconductors and components for oscillators; integrated circuit oscillators; the operation and troubleshooting of oscillators; and sources of supplies and information on oscillators.

Representative circuit diagrams for each oscillator type dealt with are given in the book. These are intended mainly to illustrate the typical basic features of the circuits discussed and are not necessarily meant to be used as designs for practical interpretations.



ELECTRONICS IN MUSIC. By F. C. Judd.

189 pages, 150 x 230 mm. (6 x 9 in.). Published by Neville Spearman Limited. Price £3.15.

The marriage of music and electronics has certainly been fruitful. Apart from the incidental fact that electronics permits the recording and reproduction of music which very closely approaches the original, the two arts in congress have produced new sounds and techniques which would have been considered completely impossible some 30 years ago.

'Electronics In Music' sets out to introduce the reader to all that is happening currently in this field, and it covers virtually the entire scene ranging from such simple devices as the Theremin to the Moog Synthesizer. The book commences with a chapter dealing with the basic attributes of musical sounds, including tone generation, vibrato and tremolo, filters and sound reproduction; then carries on to electronic musical instruments, discussing amongst other things the electronic organ and the electric guitar. The third and fourth chapters are devoted to synthetic sound and electronic music respectively, the fifth to tape recorders and their operation, and the sixth to music reproduction.

Each subject is dealt with in considerable detail. For instance, just a few of the points covered in the chapter on electronic music are sine wave, square wave and noise generators, musique concrete and Oramics. Circuit diagrams for filters and generators are given, and the book includes 20 pages of photographs. These mainly show manufactured equipment, together with some home-constructed items and a picture of the lavishly equipped Putney studio of Dr. Peter Zinovieff.

The book fills a gap in the literature very effectively, and will have appeal for the reader who is interested in this exciting and creative new art form.

The 'SLIDING JUNIOR'

AMPLIFIER

by

Sir Douglas Hall, K.C.M.G., M.A. (Oxon)

Incorporating the author's 'sliding bias' Class A circuit, this a.f. amplifier is primarily intended for use with the 'Hiflex' personal receiver. It may also be employed with other signal sources having a medium to low output impedance.

IN A PREVIOUS ARTICLE DESCRIBING THE AUTHOR'S 'Hiflex' personal receiver¹ it was stated that an a.f. amplifier, especially designed for use with it, was on the way. This article describes the amplifier. It incorporates a speaker and is supplied by a 3 volt battery which also provides the power required by the 'Hiflex' receiver.

The 'Sliding Junior' amplifier can also be used with other apparatus having a low impedance output of the order of 10k Ω or less, for which purpose an input socket is provided. There must, however, be a capacitor in series with the output of the apparatus, such a capacitor being required to fulfil a requirement, which will shortly be made clear, in the basic operation of the amplifier. If such a capacitor is not present, a 0.1 μ F capacitor should be added in series. If the apparatus has a high output impedance or resistance, the amplifier may not function satisfactorily even when a series 0.1 μ F capacitor is added, as the sliding bias effect could be excessively moderated. With the 'Hiflex' receiver the required capacitor is automatically provided by C3 in the receiver circuit.

Amplifier output is fairly modest at about 100mW, but a sensitive 8in. by 5in. loudspeaker gives plenty of volume at that level. Sensitivity is ample for all the louder signals received on the 'Hiflex', but is less than that provided by the author's earlier 'Sliding Challenger'.² With some apparatus a pre-amplifier would be required. The present amplifier gives a good output when used with the author's DRC3 short-wave receiver, but is not fully loaded by the earlier DRC2.³

As a digression, the author would remind constructors that it is useless to judge probable results on amplifier output power alone without taking into account speaker sensitivity. Modern speakers vary enormously in sensitivity. Some have a high electro-acoustic efficiency whilst others have a very low efficiency. Very small speakers are relatively inefficient, and some high fidelity systems have very low sensitivity even though they may give excellent quality. Fortunately, most inexpensive speakers which are not smaller than about 8in. by 5in. have a high electro-acoustic efficiency, and are well suited for use with an amplifier of the present type.

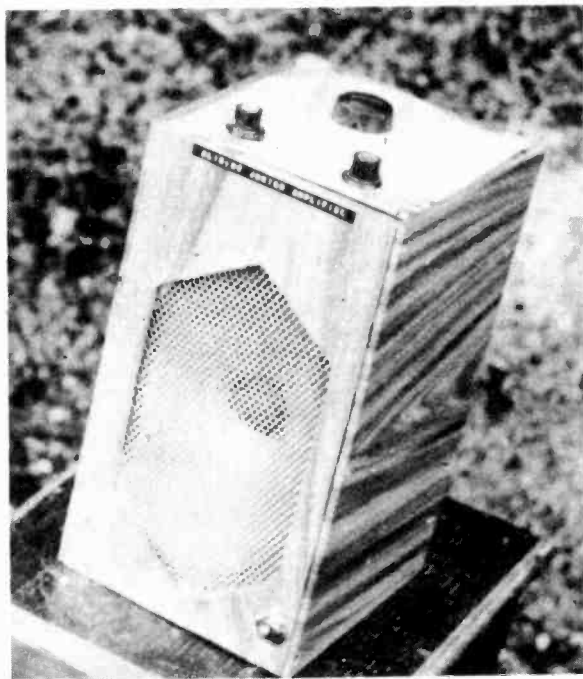

The complete assembly, with the 'Hiflex' receiver fitted into the top of the 'Sliding Junior' case

¹ Sir Douglas Hall, 'The "Hiflex" Personal Receiver', *Radio & Electronics Constructor*, May 1973. This issue is available, while stocks last, at 20p plus 6p postage.

² Sir Douglas Hall, 'The "Sliding Challenger" 200-250mW Economy Amplifier', *The Radio Constructor*, August 1970.

³ Sir Douglas Hall, 'The DRC3 Bandsread Short Wave Receiver', *The Radio Constructor*, June 1972; 'The "Spontaflex" Transistor Short Wave Receiver', *The Radio Constructor*, January 1968; 'Developing the "Spontaflex" Short Wave Receiver', *The Radio Constructor*, February 1970. The last two articles describe DRC2 receivers.

THE CIRCUIT

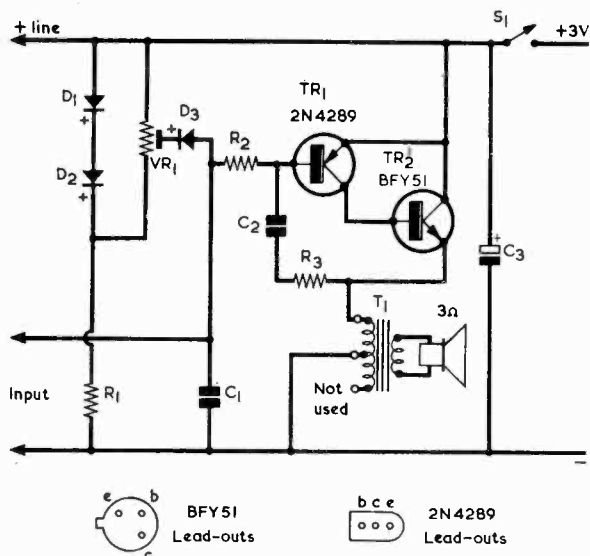

Fig. 1. The circuit of the 'Sliding Junior' a.f. amplifier

COMPONENTS

Resistors

(All values $\frac{1}{2}$ watt 10%. RA is added to the 'Hiflex' receiver)

R1	1k Ω
R2	10k Ω
R3	220k Ω
VR1	1.5k Ω pre-set, miniature skeleton
RA	100 Ω

Capacitors

C1	1,000pF paper or plastic foil
C2	0.01 μ F paper or plastic foil
C3	800 μ F electrolytic, 4V. Wkg.

Semiconductors

TR1	2N4289
TR2	BFY51
D1, 2, 3	Silicon diodes (see text)

Inductor

T1	Output transformer type TT56 (Repanco)
----	--

Switch

S1	S.P.S.T., toggle
----	------------------

Speaker

3 Ω speaker, 8in. by 5in.

Battery

3 volt No. 800 battery (Ever Ready)

Miscellaneous

Phono socket
6 way tagboard 2 $\frac{1}{2}$ in. by 2 $\frac{1}{2}$ in.
Speaker gauze
Plywood, hardboard, pegboard, Fablon or Contact, etc.

The circuit of the amplifier is shown in Fig. 1. The input signal is applied to the base of TR1, a high gain silicon p.n.p. transistor. R2 and C1 form a filter which reduces the level of any residual radio frequencies that may be present. Part of the audio signal is rectified by D3, through which the standing bias for the base of TR1 is passed. The rectifying circuit is completed by the series capacitor in the output of the apparatus coupled to the amplifier, as was mentioned at the beginning of this article. The level of the standing bias at the base of TR1 is set by means of pre-set potentiometer VR1. The incoming signal thus increases the negative bias available for the base of TR1, the increase being proportional to the amplitude of the signal. Diodes D1 and D2, across VR1, maintain the voltage across this potentiometer at a virtually constant figure despite the gradual fall in supply voltage as the battery ages, and the slider of VR1 is set so that TR2 passes about 8mA when no signal is applied to the amplifier.

Since TR1 is directly coupled to TR2, the base bias for TR2 is the collector current of TR1. Assuming a current gain of about 80 for TR2, its base current, for a collector current of 8mA, is about 100 μ A. TR1 will perform perfectly satisfactorily at this level of current. At maximum signal peaks, which automatically increase the bias on TR1 base, TR2 will momentarily pass a current of about 80mA and TR1, consequently, about 1mA. The circuit is, of course, a simple form of 'sliding bias' amplifier and, although it gives the economy of Class B operation, it works effectively in Class A. The author prefers this type of amplifier to the much more common Class B designs.

TR2 operates as an emitter follower output device, with the output signal taken from its emitter circuit. An output transformer with a low d.c. resistance is used in preference to a high impedance speaker in order to prevent the otherwise excessive voltage drop which would be caused by the resistance of the speaker's speech coil at maximum output. The use of the transformer enables the whole of the 3 volts supplied by the battery to be usefully employed in providing output.

C2 and R3 provide negative feedback. This is essential to ensure that the signal voltage is always less than the direct voltage resulting from rectification by D3, so that overloading is avoided. The values of C2 and R3 are such as to deliberately introduce a little treble cut. This compensates for a tendency towards excess of treble in the output of the 'Hiflex' receiver due to an inductor in its output circuit. Experimenters may vary the values of C2 and R3, remembering that if R3 is made too large there will be distortion due to overloading. Increasing the value of C2 introduces bass cut, and decreasing the value of R3 increases treble cut.

C3 is the usual large value electrolytic capacitor across the battery.

In the Components List the diodes are specified simply as silicon diodes. Any silicon diode or small silicon rectifier, such as the 1N4002, may be used here. Note that an additional 100 Ω resistor, which is not shown in Fig. 1, is needed. This resistor is added to the 'Hiflex' receiver, and is shown in the Components List as RA. A 6-way tagboard measuring approximately 2 $\frac{1}{2}$ by 2 $\frac{1}{2}$ in. is required for the amplifier. This tagboard is available from Home Radio under Cat. No. BTS11. If difficulty is experienced in obtaining the 1.5k Ω skeleton potentiometer specified for VR1, this may be obtained

from Amatronix Ltd., 396 Selsdon Road, South Croydon, Surrey, CR2 0DE.

CONSTRUCTION

Construction commences by cutting out six pieces of $\frac{3}{4}$ in. plywood, as shown in Figs. 2(a) to (e). Two pieces are required, as in Fig. 2(d); and one each as in Figs. 2(a), (b), (c) and (e). As will be gathered from the photographs the final assembly constitutes a frame into which the 'Hiflex' receiver can be fitted. All the 5in. dimensions in Fig 3 assume that the 'Hiflex' panel has been cut exactly 5in. square. If, in practice, it is a little

larger, the 5in. dimensions in Fig. 2 should be modified accordingly.

It is suggested that the speaker panel of Fig. 2(c) be completed first. A suitable aperture is cut out for the speaker and the panel front is then covered with Fablon or Contact before the speaker is screwed into place over a piece of metal gauze. The battery switch and input socket are also mounted after the panel has been covered.

Fig. 2(a) shows the baseboard, and this may next be cut out. Holes should be drilled for the three 4BA bolts shown in this diagram. The two outside bolts are 2in. long and the central one $\frac{3}{4}$ in. long, and all three are

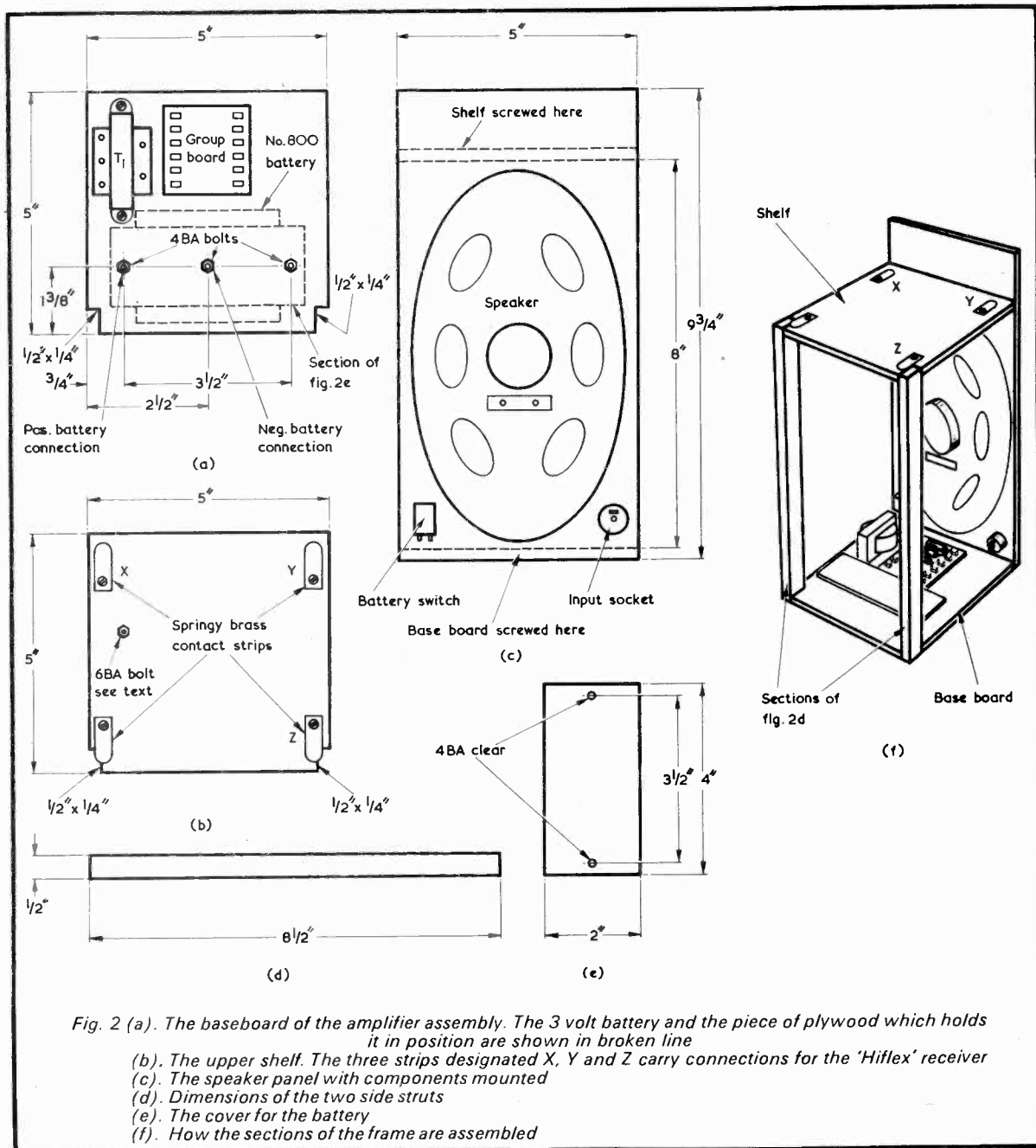
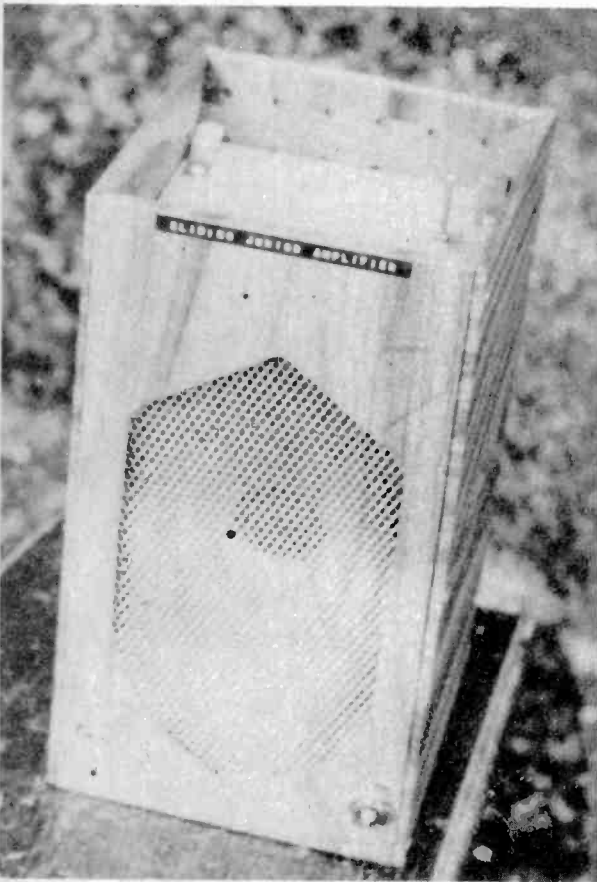

Fig. 2 (a). The baseboard of the amplifier assembly. The 3 volt battery and the piece of plywood which holds it in position are shown in broken line
 (b). The upper shelf. The three strips designated X, Y and Z carry connections for the 'Hiflex' receiver
 (c). The speaker panel with components mounted
 (d). Dimensions of the two side struts
 (e). The cover for the battery
 (f). How the sections of the frame are assembled

countersunk types. The bolt heads are below the baseboard, so that the bolt ends point towards the reader. Solder tags are placed, above the board, under the nuts securing the central bolt and left-hand bolt, as seen in Fig. 2(a). The battery, which is a 2-cell cycle lamp type, is placed between the two outside bolts so that the positive terminal strip makes contact with the left hand bolt and the negative terminal strip makes contact with the central bolt. The right hand bolt merely assists in holding the battery in position. Next cut out and drill the piece of plywood shown in Fig. 2(e). This piece is passed over the two outside 4BA bolts of Fig. 2(a) when the battery is fitted and, by means of two 4BA nuts passed over the bolt ends above it, holds the battery down firmly.

Place the tagboard and transformer T1 approximately in position, as shown in Fig. 2(a), but before screwing these components down to the baseboard hold the speaker panel temporarily up against it in the position shown in Fig. 2(f) to make sure that none of the components will foul each other. Then screw the tagboard and T1 in position. T1 may be mounted by means of solder tags soldered to the feet of its clamp.



The amplifier with the receiver removed

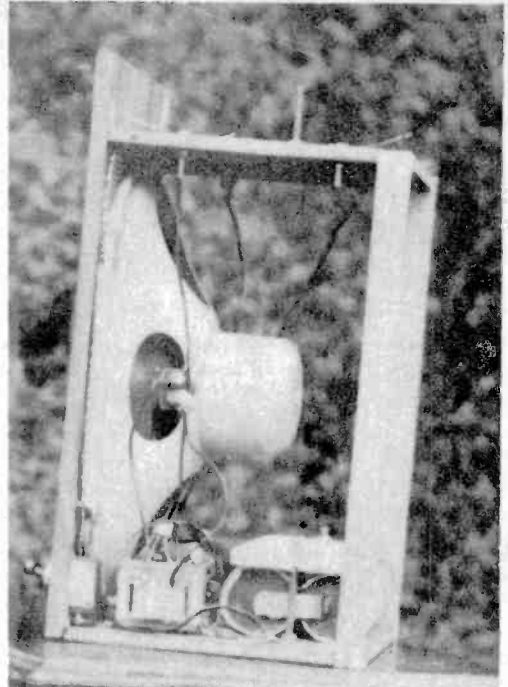

The amplifier frame before the sides and rear are fitted. The projecting 6BA bolt may be seen at the top

Cut out the section shown in Fig. 2(b) and fit the four pieces of springy brass strip, as illustrated. In the prototype these were taken from old No. 800 batteries. These should be positioned so that the ends of the four 1in. 4BA bolts used as 'legs' for the 'Hiflex' make contact with them when the 'Hiflex' is placed on the shelf. The 'Hiflex' takes up a position such that the volume control and wavechange switch are towards the speaker panel. Only three of the strips, those indicated as X, Y and Z, are used for making contact and it is useful to tin these with solder to reduce contact resistance. Also, solder tags are fitted, below the shelf, under the nuts of the bolts which secure strips X, Y and Z in position. No solder tag is needed at the fourth strip, and this strip need not be tinned. It is provided merely to ensure a level standing for the 'Hiflex'. The letters X, Y and Z are used in later drawings to identify the brass strips and the 'Hiflex' bolts which connect to them. The 6BA bolt shown in Fig. 2(b) is fitted later.

Next, cut out the two plywood pieces shown in Fig. 2(d). Then turn to Fig. 3(a) and wire up small components on the tagboard as illustrated. The leads of some of the components are shown, for clarity, longer than they need be. In practice, all component lead-outs should be reasonably short. Assemble the frame, as shown in Fig. 2(f). The two pieces of Fig. 2(d) are used as supports, being screwed to the baseboard and shelf at the $\frac{1}{2}$ in. by $\frac{1}{4}$ in. cut away sections. Finally, complete the wiring illustrated in Fig. 3(b). Note that connections are made to the solder tags at the two battery connection bolts, and at the three bolts identified as X, Y and Z.

SETTING UP

The only setting up process required is the adjustment of VR1. Initially, this potentiometer should be set up
RADIO & ELECTRONICS CONSTRUCTOR

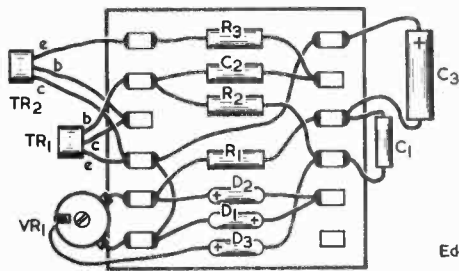

(a)

Fig. 3 (a). The smaller components are assembled on a 6 way tagboard
(b). How the tagboard is wired into the complete circuit

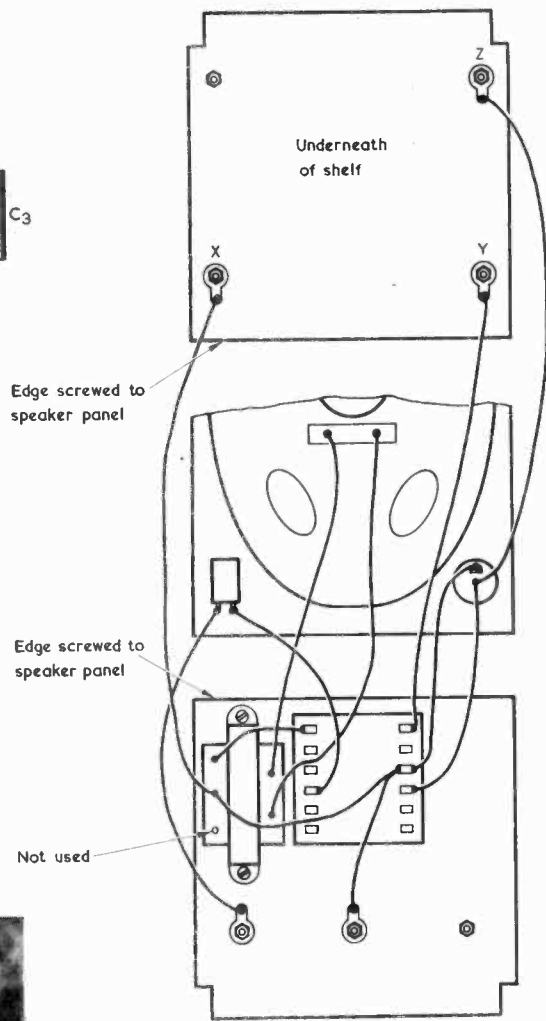

(b)

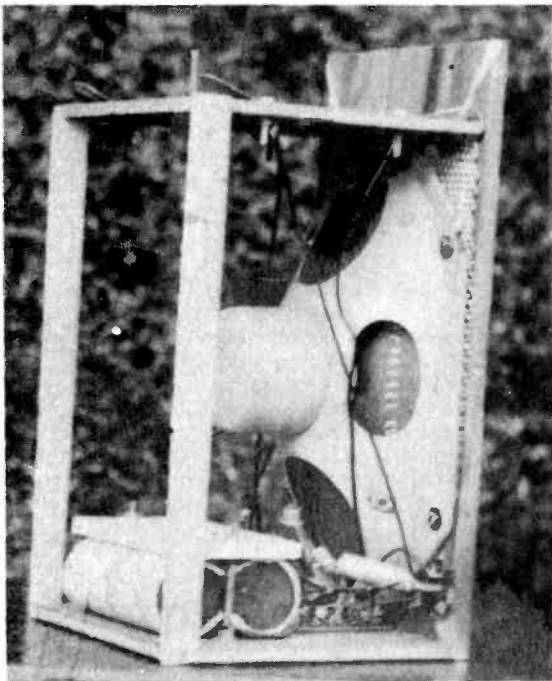

Another view of the amplifier frame

such that its slider is at the end of the track which connects to the positive supply line. As shown in Fig. 3(a), this is fully anti-clockwise. A 3 volt battery is then temporarily connected to the battery connection bolts with a current-reading meter in the positive supply line. The amplifier is switched on and VR1 adjusted for a reading of 8mA in the meter. It will be found that the slider is then fairly close to the other end of the track.

No case as such is made, but two pieces of hardboard, each measuring 9½ in. by 5½ in., are cut, covered with Fablon or Contact and screwed to the sides of the frame of Fig. 2(f). The screws pass into the edges of the speaker panel and the two plywood struts at the rear. The hardboard panels should not be finally fitted until modifications to the 'Hiflex' receiver have been carried out. A piece of pegboard, 9½ in. by 5 in. serves as the back, this being screwed to the edges of the two struts. The back is not covered, but an inch or so of Fablon or Contact at the top will ensure a neat appearance when the assembly is viewed from the top. A cavity is now available at the top which takes the 'Hiflex' receiver.

'HIFLEX' MODIFICATIONS

Modifications have next to be carried out on the 'Hiflex'. Three of the four 4BA bolts used as 'legs' are wired up to provide suitable circuit connections with the brass strips on the amplifier shelf. Details are given in Fig. 4. The bolt at Z connects to the 'Hiflex' output, and the additional 100Ω resistor, shown as RA, is wired in series with the positive supply. The 100Ω resistor provides decoupling in association with the large value electrolytic capacitor already connected across the supply rails of the 'Hiflex', whereupon the large amplifier battery can also supply the receiver circuits without introducing instability.

Also, a switch is added to the 'Hiflex' so that its battery cells are automatically cut out when the receiver is dropped into the compartment at the top of the amplifier. The switch is home-constructed and consists of two pieces of springy brass strip, one passing under the other at right angles and bent so that the two are in contact until it is pressed away. In the prototype, a negative terminal strip taken from a No. 800 battery was used for the fixed contact. This already has approximately the shape required and is able to straddle the other contact. The latter can be a positive battery terminal strip, screwed to the panel at one end only. Both strips are tinned with solder over the areas at which they make contact.

The negative battery lead of the 'Hiflex' is cut and rewired through this new switch. It is intended that, when the 'Hiflex' is fitted in its compartment, the end of the 6BA screw in the shelf of Fig. 2(b) pushes the moving contact of the added switch away from the fixed contact. The 6BA bolt is fitted in the requisite position on the shelf, this position being marked off with the aid of the receiver. The bolt may be 1¼ in. long in the first place, but it will probably need to be clipped down a

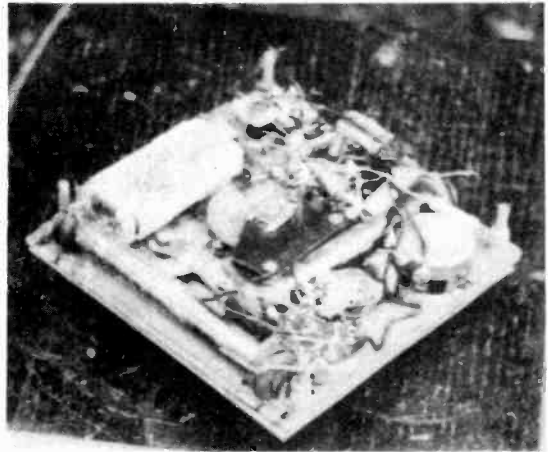

The modified 'Hiflex' receiver. The added switch contacts are just discernible alongside the tuning capacitor

little with a pair of pliers to make it exactly the right length to operate the switch correctly. The two hard-board sides of the amplifier assembly should not be fitted while the exact position required for the 6BA screw is being found and while, later, it is being cut to the desired length. The operation of the added switch can then be readily observed.

There is now no need to remove the two battery cells from the 'Hiflex' when it is being used with the amplifier. But it is necessary to turn the 'Hiflex' switch to the Off position if it is removed from the amplifier, as this action will otherwise turn the receiver on. When the 'Hiflex' is used with the amplifier, only the amplifier's switch needs to be employed to control both the amplifier and the receiver. If the amplifier is used with other apparatus, the 'Hiflex' must be removed from its compartment.

Clearly, if the constructor does not object to removing the cells from the 'Hiflex' each time this is used with the amplifier, there is then no need to make and fit the new switch.

RESULTS

Employing the 'Hiflex' receiver in conjunction with the 'Sliding Junior' amplifier results in a combination having surprisingly pleasant output quality with plenty of bass and ample power for normal domestic listening. As regards economy of operation it should be remembered that, other things being equal, the power which can be delivered by a battery may be expected to be roughly proportional to its weight. The No. 800 battery used here weighs just six times as much as, say, a PP3 type; but, at the time of writing, the PP3 is the more expensive!

Before concluding this article the author would like to state that he has now designed a short wave receiver covering a range from below 6MHz to greater than 18MHz which also operates from a 3 volt supply. This may be used on its own as a personal receiver or it may be fitted to the 'Sliding Junior' amplifier in the same manner as the 'Hiflex' receiver. This new receiver will be described shortly in *Radio and Electronics Constructor*.

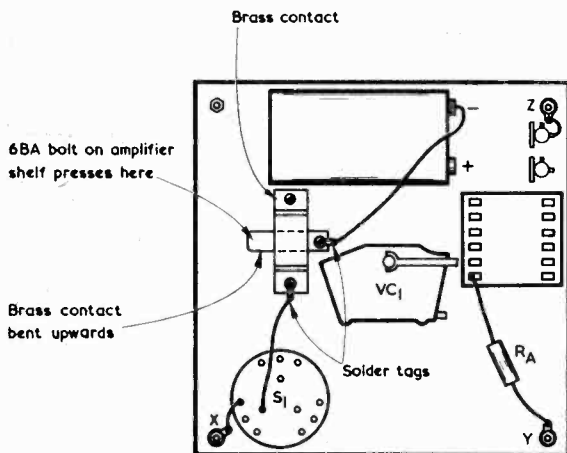

Fig. 4. Modifications to the 'Hiflex' receiver. These comprise making connections to three of the 4BA bolts which project on the underside of the panel and the addition of a switch which automatically cuts out the 'Hiflex' battery when this is fitted to the amplifier

COMBINATION LOCK

By J. D. Parkinson

An ingenious approach to the design of electrical combination locks incorporating multi-way rotary switches.

AT FIRST SIGHT AN ELECTRICAL COMBINATION LOCK may seem to require a simple circuit such as that of Fig. 1, in which two 1-pole 12-way switches are connected in series. For clarity, only 6 of the ways are shown in Fig. 1. When the correct switch settings have been selected the relay energises, and its contacts cause a solenoid to operate and withdraw a bolt which otherwise holds closed a box to which the switches are fitted.

The number of possible combinations in Fig. 1 is 143 (12 times 12 minus 1 for the 'at rest' position). However, it would only take a minute or so to find the combination by the 'round and round' method. This consists of turning S2 through all its positions for each of S1's positions. It would therefore be necessary to fit an alarm system, but the speed at which this lock can be opened means that assistance might arrive too late. A better approach, of course, is to try and prevent the combination being found. With this aim in mind the basic circuit of Fig. 2 was arrived at.

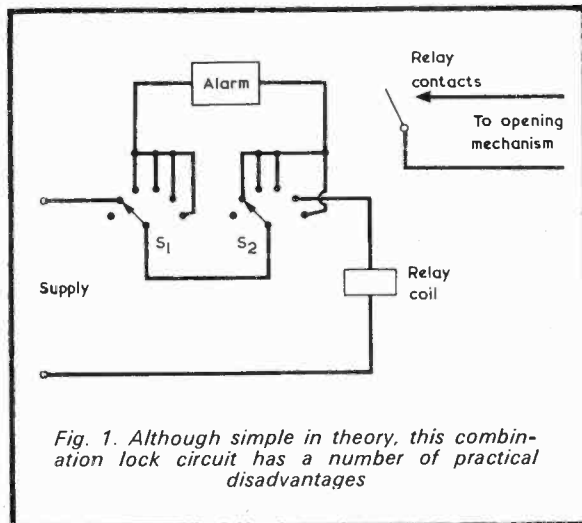

Fig. 1. Although simple in theory, this combination lock circuit has a number of practical disadvantages

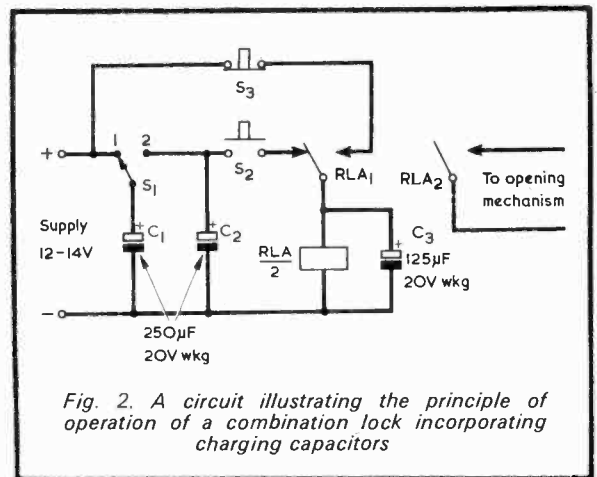

Fig. 2. A circuit illustrating the principle of operation of a combination lock incorporating charging capacitors

CHARGING CAPACITORS

When S1 of Fig. 2 is in position 1, C1 charges to the supply potential. When S2 is set to position 2, the charge is shared equally with capacitor C2, giving the latter a potential across its plates equal to half that of the supply. This is not enough to trigger the relay, therefore S1 is returned to position 1 to recharge C1 and then back to position 2 to bring C2 up to three-quarters of the supply voltage. If S2 were pressed now the contacts of relay RLA would tremble but not close. So for a third time S1 is changed to position 1 and then back to position 2 to bring the voltage on C1 and C2 to seven-eighths of the supply.

Pressing S2 will now pass sufficient charge to C3 to enable the relay to be energised. Contacts RLA1 change over, causing the relay to be held on via S3. At the same time, contacts RLA2 close and operate the opening mechanism. If C3 is omitted the relay simply 'chatters' when S2 is pressed. S3 is pressed when it is desired to release the relay.

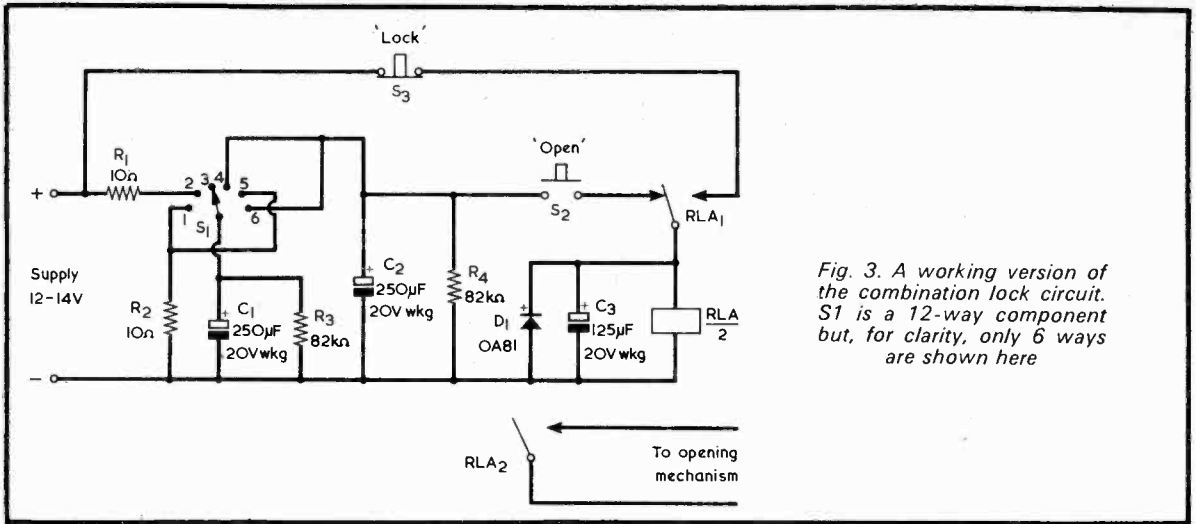

Fig. 3. A working version of the combination lock circuit. S1 is a 12-way component but, for clarity, only 6 ways are shown here

The circuit of Fig. 2 does not prevent the 'round and round' type of switching from charging C2. If, however, S1 is changed for a 12-way switch, additions can be made which guard against this method of operation.

The requisite circuit is shown in Fig. 3. S1 is a 1-pole 12-way switch of which, for clarity, only 6 ways are shown. No connections are made to the remaining contacts. R3 and R4 have been placed across capacitors C1 and C2 to continually discharge them. This sets a limit to the time that can be taken opening the lock. R2, connected in this example to contacts 1 and 5, provides the arrangement that prevents 'round and round' switching from opening the lock. If S1 is rotated in either direction R2 discharges C1 first via contact 1 or contact 5. C2 is then discharged into C1 via contact 6 or contact 4. This prevents C2 from attaining the required charge to energise the relay. R2, of course, cannot be connected to any contacts on the track between the supply and the 'charge C2' contact (i.e. it cannot be connected to contact 3).

The values of R3 and R4 may be changed to suit individual requirements. It is desirable for their values to be approximately equal.

The combination for the circuit of Fig. 3 is 242424 - open. If someone who did not know this wanted to open the lock, and assuming he knew it took 6 digits, which in itself is unlikely, he would be faced with over 1,000,000 possible combinations. In the even less likely case of him knowing that it required the first two digits repeated twice to open the lock there would be just over 120 combinations he would try.

FURTHER COMBINATIONS

For those who think this number of combinations not high enough, a further increase is possible with the circuit of Fig. 4. S1 is changed to a 2-pole 12-way switch and, after C2 has become sufficiently charged, this has to be set to position 5 before the relay can be energised via S2. In this example the combination is 2727275 -

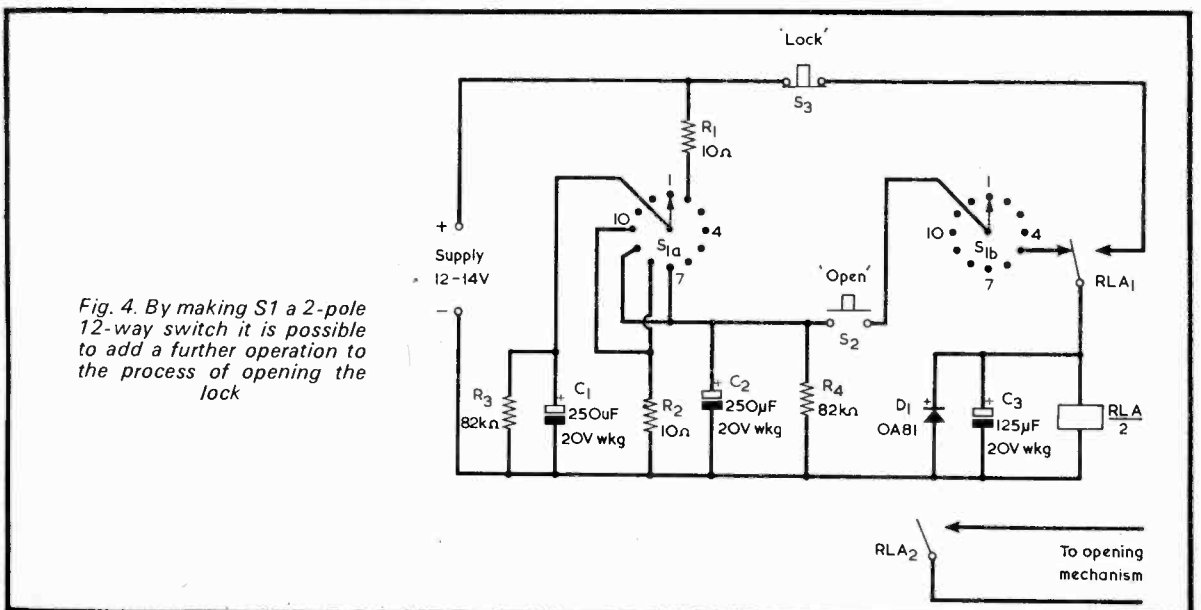

Fig. 4. By making S1 a 2-pole 12-way switch it is possible to add a further operation to the process of opening the lock

open.

The attraction with both these locks is that it takes six or seven digits to open them, but there are only two or three to remember. Another attraction is that, apart from the instance when the lock is being opened, current will only be drawn if S1 is left with R1, C1 and R3 across the supply. It should therefore always be a rule that, on locking, S1 must be returned to position 1.

Although the supply is only 12 to 14 volts, the back e.m.f. from the relay, when switching off, is quite high. It is enough to give a mild shock to anyone holding

relevant wires or terminals at the time. To eliminate this D1 is placed across the relay coil.

The relay can be any small type having to changeover contacts or one changeover contact and a make contact, together with a coil resistance of 200 to 700Ω and an operating voltage lower than 12 volts. It will be apparent that some experiment may be necessary and it may be desirable to employ electrolytic capacitors having different values to those shown. A suitable source of supply will be given by three 4.5 volt bell batteries connected in series. ■

New Products

NEW MINIATURE PORTABLE SOLDERING IRON

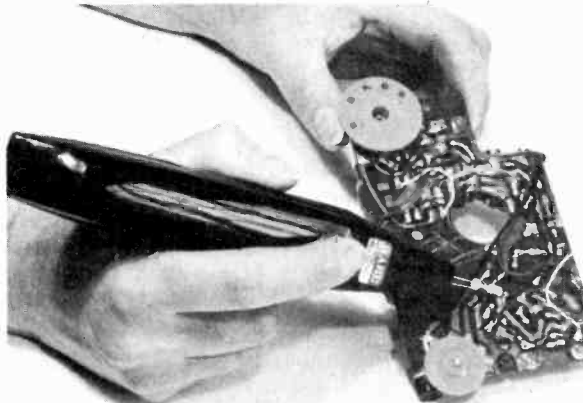

Soldering with the new 8" long portable, lightweight soldering iron – which is rechargeable and can be used far from a power source – launched by the VAN DUSEN AIRCRAFT SUPPLIES COMPANY in the U.K. and Europe. The "ISO-TIP" soldering iron, weighing less than 6 ounces, has been designed to handle, with speed and efficiency, every industrial or domestic soldering requirement.

The VAN DUSEN AIRCRAFT SUPPLIES COMPANY have launched a portable, lightweight, miniature soldering iron – which is rechargeable and can be used far from a power source to handle, with speed and efficiency, every industrial or domestic soldering requirement.

The new 8" long "ISO-TIP" soldering iron – weighing less than 6 ounces – is now available for the first time in the U.K.

The cordless soldering iron is simple to use and eliminates all the usual over-heating risks. A normal solder should be used and the iron – which combines low voltage with high wattage performance – is, at the press of a button, instantly ready for use.

In addition, the specially constructed soldering "ISO-TIP" eliminates all need for earthing and removes the possibility of electrical leakage – which could damage highly sensitive electronic components – occurring.

The iron is ideal for use in restricted spaces where manipulation is difficult and for all general purpose soldering repair work on domestic wiring systems, printed circuit boards and general radio and television work.

The "ISO-TIP" soldering iron – with a tip performance of up to 50 watts and a capacity for up to sixty joints, dependent on size, per charge – reaches soldering temperature in 3–5 seconds. The well balanced iron is comfortable to hold and has a built in pilot and work light to ensure the accurate positioning of solder joints when working in enclosed areas.

A choice of two special recharging stands – to plug into mains 240V or 120V supply – are supplied with the iron and this will recharge the nickel cadmium batteries which provide the power source from "dead" to full charge overnight.

The price of the entire unit and stand is £8.75 and replacement tips are available for 80p.

Full technical details of the new, "ISO-TIP" soldering iron, are available from the VAN DUSEN AIRCRAFT SUPPLIES COMPANY, Oxford Airport, Kidlington, Oxon.

THE 'CONCORDE PROFESSIONAL' TRIMMING KNIFE

The "Concorde Professional" is a new trimming knife introduced by Spiralux and intended for use by the man who uses a trimming knife all day, every day. It is designed to fit the hand and to be gripped with ease. It is well balanced and has appreciable weight to ensure constant accuracy of cut. Blade replacement is quick and easy – no fiddling with coins or screwdrivers. The base of the knife simply twists off and the body swivels to allow the used blade to be removed and a new blade inserted. The die-cast body of the Concorde Professional will house five spare blades and the recommended retail price is 75p.

Details from Hollands & Blair Ltd., Bensham Grove, Thornton Heath, Surrey.

JUNE 1973



SHORT WAVE NEWS

FOR DX LISTENERS

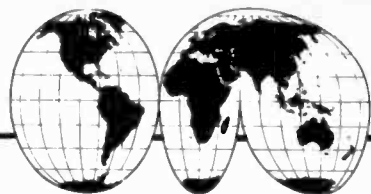

By Frank A. Baldwin

Times = GMT

Frequencies = kHz

There are many types of programmes radiated on the short wave bands, some have entertainment value whilst others present cultural material, a few have formats of learned content and there are those which feature religion, either partly or wholly, as a matter of policy. Most stations offer newscasts of both local and world events, such reviews are sometimes factual whilst others are 'coloured' to some degree, many being downright propaganda and little else. Those stations broadcasting the latter type of news service also tend to have programmes of the same type.

Propaganda stations of one sort or another abound but probably those of most interest are the so-called clandestine transmitters. Some of these, like Radio Espana Independiente on 15185 (19.75m), are well known, whilst others are not and it is some of these that we feature below.

● CLANDESTINE

On 6240 (48.07m) we have the latest 'underground' station to engage the attention of Dxers, this being a transmitter of the PAIGC (African Party for Independence of Guinea and Cape Verde). This station was first heard by Al Martin of St. Helens in early March and by many others since. The language used is Portuguese and the station closes with an unknown anthem at 2300. We logged it at 2238 when a programme of African-type music with Portuguese announcements was being radiated. The station is cleverly 'sited' for on 6250, just 10kHz away, is Santa Isabel, Equatorial Guinea. (Acknowledgement to 'Bandspread' for this item).

Liberation Radio has a scheduled European Service in English from 2030 to 2045 on 10010 (29.97m) and on 12117 (24.75m) although 'Bandspread' reports it on 14992 (20.01m) in parallel with 12117, having dropped the 10010 channel.

The station also has a 30-minute English transmission at 1100, 1230, 1430 and at 2330 (scheduled) on 7470 (40.16m) and on 10010. Liberation Radio is based in Hanoi. (Pro-communist).

Voice of the Patriotic Militiamen's Front, reportedly operated by the American CIA, is still (at the time of writing) active on 9430 (31.81m) according to "Bandspread", being heard at 1415 with accordion, cymbals, interval signal and clear identification. This one is probably based in South Vietnam.

Voice of the Front of United Nationalities in Iran reportedly operates from 1500 to 1600 on 9600 (31.25m) being in Persian, Arabic and Baluchi. (Pro-communist).

Voice of the Revolutionary Party for Reunification operates on 4563 (65.74m) from 1000 to 1400 and from 2100 to 2300 in Korean. (Pro-communist).

● CURRENT SCHEDULES

● SWITZERLAND

SBC Berne radiates programmes in English from 0645 to 0730, 1100 to 1130, 1300 to 1345, 1515 to 1600, 1800 to 1815 and from 2100 to 2130 on 3985 (75.28m)

from 1515 only on this channel, 6165 (48.66m) and on 9535 (31.46m).

● HOLLAND

Radio Nederland operates an English transmission schedule as follows, from 0930 to 1050 on 6140 (48.85m) and on 7275 (41.23m); from 1400 to 1520 on 6020 (49.83m), 11740 (25.55m), 17810 (16.84m) and on 21480 (13.96m); from 1830 to 1950 on 6020 and on 6085 (49.30m).

● INDIA

All India Radio operates a General Overseas Service in English to the U.K., Africa and Europe from 1745 to 1945 on 7215 (41.58m), 9525 (31.49m), 11620 (25.81m), 11945 (25.11m) and on 15080 (19.89m); from 1945 to 2045 on 7215, 9515 (31.52m), 9525, 9912 (30.26m), 11620, 11960 (25.08m) and from 2045 to 2230 on 7215, 7260 (41.32m), 9525, 9912, 11620 and on 11740 (25.55m).

● MALI

Radiodiffusion Nationale du Mali, Bomako, operates a Home Service from 0600 sign-on to 2400 sign-off. The part of the service that can best be heard here in the U.K. is from 1800 to 2400 (mostly in French) on 4783 (62.72m), 4835 (62.04m) and on 5995 (50.04m). Bomako also radiates during this period on 3380 (88.75m) but rarely heard here in the U.K.

● ALGERIA

Algiers has an External Service, in Arabic, to the Arab World from 1800 to 2100 on 7270 (41.26m), 9685 (30.97m) and on 11920 (25.16m); from 2100 to 2300 on 11835 (25.34m) and on 15420 (19.45m).

● PHILIPPINES

Voice of the Philippines, Malolos, has a schedule in English from 0700 to 2200 on 9580 (31.31m), most of the programmes are for Far Eastern consumption and none are directed to the U.K. or Europe.

● NORTH VIETNAM

The Main Service now radiates in English (1st transmission) from 2230 to 2300 and from 0100 to 0130 on 10040 (29.88m) and 15105 (19.86m) and at 1000 to 1030, 1300 to 1330 and from 1530 to 1600 in the 2nd transmission on the same two channels. Also from 1800 to 1830 on 7040 (42.61m) and on 10040.

● TUNISIA

The Tunisian Home Service, in Arabic, can be logged on 11900 (25.21m) and 11925 (25.15m) from sign-on at 1458 through till 1600, also on 6195 (48.42m) from 1600 to sign-off at 2330.

● AROUND THE DIAL

● AUSTRALIA

Radio Australia has been logged on 9580 (31.31m) at 2030 in English to New Zealand and the Pacific area after station identification, also on 15265 (19.65m) at 2123 in English to S.E. Asia with "Listeners Letters" programme.

● POLAND

Warsaw may be heard in English, newscast and programme, at 2030 on 9540 (31.44m).

NETWORK PORTABLE

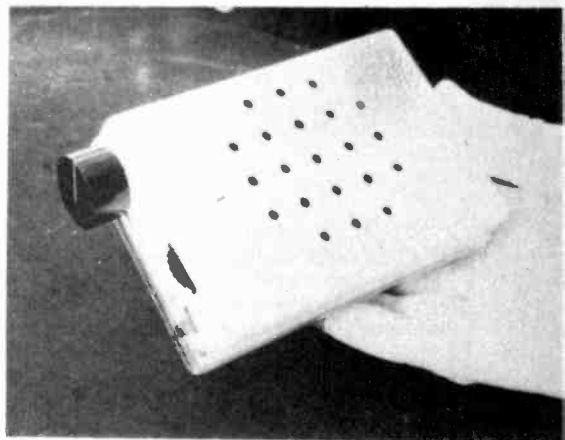

Incorporating the Ferranti integrated circuit type ZN414, this medium and long wave receiver requires a relatively small quantity of additional components. There are no alignment problems.

oc. I.E.R.E., G30GR

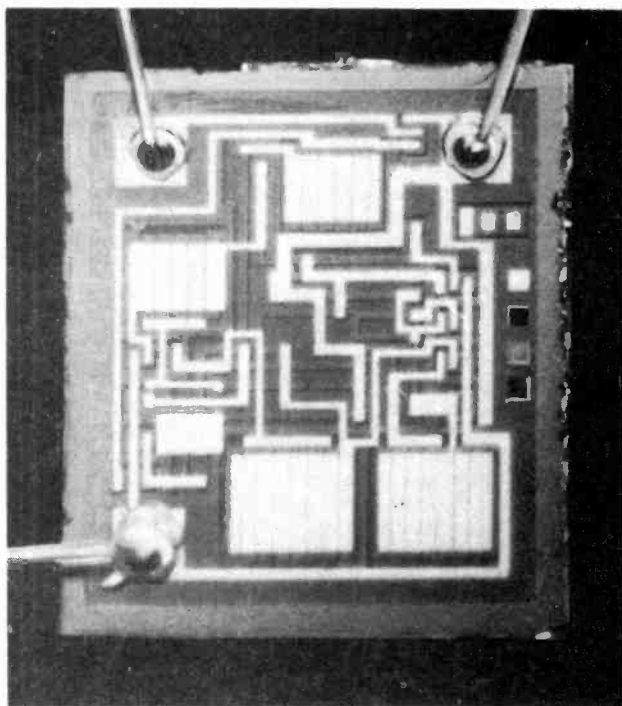
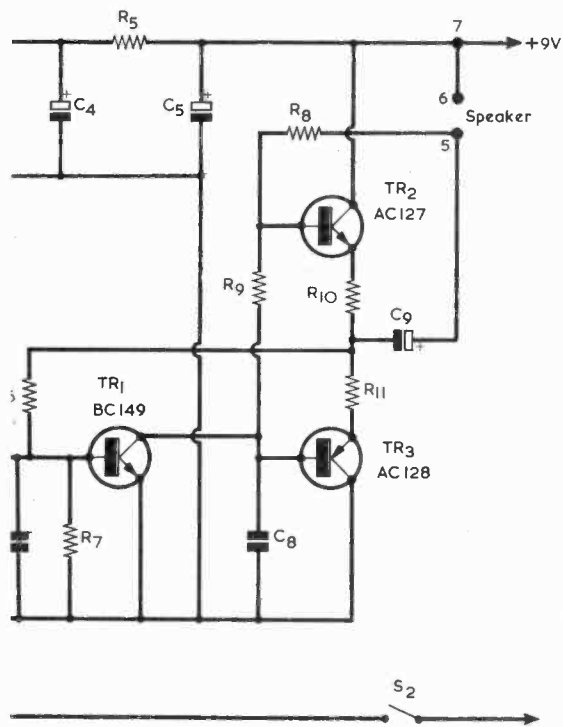

The ZN414 silicon network provides the r.f. stages and detector for an a.m. radio. The complete circuit is provided on a chip area of less than 0.6 sq. mm., and the chip is encapsulated in a 3-lead transistor package (chip area enlarged 70 times)

Photo: Courtesy Ferranti Ltd.

Numbered points correspond with Veroboard pins in the board

COMPONENTS

The fixed resistor values should be as given in the Components List. Some of the other items can be different to those specified, to make use of components on hand or for other reasons. The use of alternative components will, in some cases, necessitate the provision of a larger case than that used by the author.

L1 and L2 could be the medium and long wave sections of a ready-made transistor receiver ferrite rod aerial, the unwanted coupling windings being removed. If space permits, VC1 could be an air-spaced component of around the same value, or a 208 + 176pF 2-gang capacitor with both sections in parallel. The 'Dilemin' capacitor quoted in the Components List for VC1 is available from Home Radio under Cat. No. VC40B.

Alternative values for VR1 are 10k Ω and 20k Ω log. The potentiometer employed by the author was a 5k Ω edge-operated miniature component which was capable of being secured by a bolt passed through the centre of its body. If the type obtained by the constructor is designed for mounting by its solder tags, two small tin-plate or brass brackets should be devised to which two of the potentiometer tags may be soldered. The brackets are then secured to the side of the case. On-off switch S2 is incorporated with VR1.

Of the capacitors, both C6 and C8 may be 0.4 or 0.5 μ F. C4 can in practice have any value between 2 and 25 μ F, with a working voltage of 2 volts or higher. A value of 150 μ F or more is satisfactory for both C5 and C9, but C5 must not have a working voltage lower than 10 volts.

The speaker used by the author is the type TP26G from Electrovalue. This is nominally 75 Ω (but may be marked '80 Ω ') and is 2 $\frac{3}{4}$ in. in diameter. Any speaker impedance from 30 to 80 Ω is satisfactory, but alternative types may not fit into the particular case and layout employed for the prototype.

The case used by the author was chosen from a range of bait and tackle transparent boxes available from sports shops and shops selling fishing tackle. Its size is 3 $\frac{1}{4}$ by 4 $\frac{3}{4}$ by 1 $\frac{1}{4}$ in. and this is just sufficient to accommodate the components with no awkward crowding. The controls are located so that there are no projections on the front and long sides. Where a transparent case is not wanted, the box should be painted, on the *inside*, before fitting the parts. Any household or similar oil paint is suitable.

If preferred, a case could be made up from $\frac{1}{16}$ in. Perspex sheet, or similar material. Somewhat similar trinket boxes are also available in some shops. A metal box cannot be used.

The ferrite aerial used in the prototype was wound on a rod approximately 2 $\frac{3}{4}$ in. long with a diameter of $\frac{3}{8}$ in. This can be broken from a longer rod by carefully filing at the requisite point and then breaking the rod.

The ZN414 integrated circuit is available from Henry's Radio.

Resistors

(All fixed values $\frac{1}{4}$ watt 5%)

R1	100k Ω
R2	1k Ω
R3	2.2k Ω
R4	560 Ω
R5	2.7k Ω
R6	270k Ω
R7	220k Ω
R8	680 Ω
R9	47 Ω
R10	2.2 Ω
R11	2.2 Ω
VR1	5k Ω potentiometer, log, miniature edge operated, with switch S2

Capacitors

(See text for alternative values)

C1	0.01 μ F plastic foil
C2	0.1 μ F plastic foil
C3	0.1 μ F plastic foil
C4	10 μ F electrolytic, 2.5V. Wkg.
C5	200 μ F electrolytic, 10V. Wkg.
C6	0.047 μ F plastic foil
C7	0.01 μ F plastic foil
C8	0.047 μ F plastic foil
C9	320 μ F electrolytic, 6V. Wkg.
VC1	300pF variable, 'Dilemin' (Jackson Bros.)

Inductors

L1, L2 Ferrite aerial windings (see text)

Semiconductors

IC1	ZN414 (Ferranti)
TR1	BC149
TR2	AC127
TR3	AC128

Switches

S1	Miniature slide switch
S2	On-off switch, part of VR1

Speaker

75 Ω or 80 Ω speaker, 2 $\frac{3}{4}$ in. round, Type TP26G, (Electrovalue)

Battery

9-volt battery type PP3 (Ever Ready)

Miscellaneous

Knob	
Plain Veroboard,	0.15 in. matrix, 3 $\frac{1}{8}$ \times 1 in.
8 Veroboard pins	
Ferrite rod	2 $\frac{3}{4}$ \times $\frac{3}{8}$ in (see text)
Battery clips	
Plastic case	(see text)



Cover Feature

SILICON POCKET

THIS RECEIVER IS BASED ON THE FERRANTI ZN414 integrated circuit. Described by its manufacturer as a 'silicon network', this i.c. incorporates 10 transistors and is housed in a TO18 encapsulation. In addition to detection it provides all the r.f. amplification needed for an a.m. receiver, and it has a typical power gain of 70dB. With suitable operating conditions it requires only a tuned circuit at the input, as in Fig. 1, to give sufficient output for headphones or an a.f. amplifier. Since the ZN414 is of similar size to an ordinary transistor, and since it has only 3 lead-outs, it allows small receivers to be made up with very little wiring.

The network employs automatic gain control feedback. From the constructor's point of view the main advantages are that a receiver incorporating the ZN414 has no regeneration control, as occurs with most t.r.f. circuits, and has no aerial, oscillator and i.f. transformer circuits to align, as with superhets. For interest, a photograph showing the internal construction of the ZN414 accompanies this article.

RECEIVER CIRCUIT

The complete receiver circuit is shown in Fig. 1. L1 and L2 are the medium and long wave windings of the ferrite rod aerial, switch S1 short-circuiting L2 for medium wave reception. Tuning is carried out by VC1, which is a 300pF variable capacitor. Frequency coverage is approximately 2,000kHz to 600kHz with S1 closed and 550kHz to 180kHz with S1 open.

Operational information for the ZN414 indicates that selectivity can be comparable with superhet designs. It is possible, however, for very strong signals to swamp the front end of the circuit, whereupon it becomes necessary to reduce pick-up on the ferrite rod by suitably rotating the receiver.

The prototype receiver readily provided satisfactory reception of those transmissions which were normally best received in the locality. It was found that the use of a Litz-wound ready-made ferrite rod aerial increased selectivity a little over the home-wound type incorporated, but it was felt that the latter was quite satisfactory in practice.

The audio output of the ZN414 is developed across R2. The operating voltage of this part of the receiver should be 1.1 to 1.8 volts, and the requisite voltage is provided by the potential divider given by R4 and R5.

VR1 is the volume control, and its slider couples to TR1, which drives TR2 and TR3 in a directly coupled transformerless output stage. This requires relatively few components and gives good audio results.

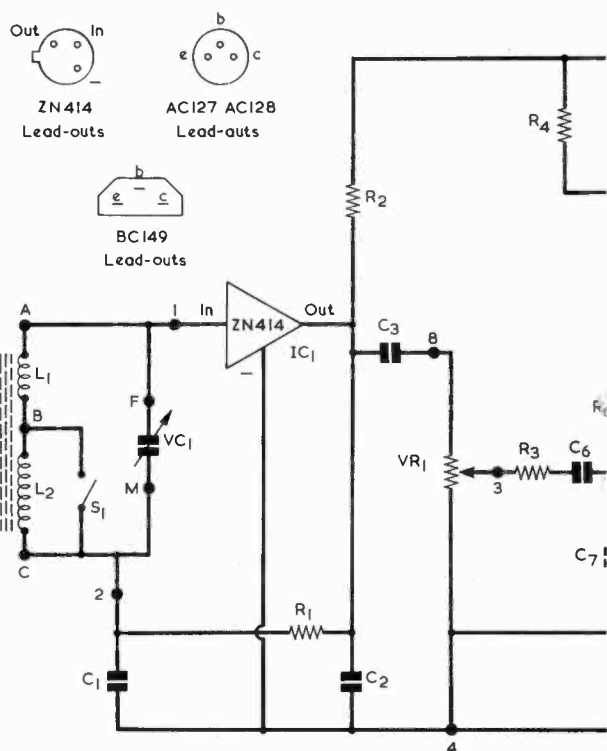

Fig. 1. The circuit of the silicon network receiver. The nun receiver L

● **VATICAN**

Vatican Radio may be heard with an English programme at 2045 on 7250 (41.37m).

● **ITALY**

Rome offers a newscast of local events in English at 1930 on 9710 (30.89m).

● **ROMANIA**

Bucharest may be logged with a programme in English at 1115 on 17820 (16.83m).

● **CANADA**

Radio Canada can also be heard on the above channel with local news and events at 1515. Sackville can also be heard in English at 2115 on 11860 (25.29m).

● **SOUTH AFRICA**

Johannesburg can be logged with local services on the LF bands, listen on 4875 (61.53m) around 2200 for the English Service or on 4965 (60.42m) at 2100 for the news in English after station identification.

● **NIGERIA**

Benin City can often be logged in the late evenings, we heard it at 2245 on the regular 4932 (60.82m) channel when a typical programme of African music and songs was being radiated. Also Lagos on 4990 (60.12m) at 2211, similar programme.

● **GHANA**

Signals from this country can be heard on 4980 (60.24m) also in the late evenings, we logged them at 2245 when the news in English was being radiated.

● **GAMBIA**

Radio Gambia. Bathurst, is now one of the best African signals on the 60m band and logged here often. Recently heard at 1955 with a talk in English about Maritime Law, 5 short and 1 long pip at 2100 then relay of the BBC World Service newscast, listen on 4820 (62.24m).

● **TIME-CHECK**

All the foregoing transmissions are listed here in time order for the convenience of readers who wish to plan their listening sessions.

GMT	Freq.	Stn.	Revd.
1115	17820	Bucharest	
1515	17820	Sackville	
1930	9710	Rome	
2030	9580	R. Australia	
2030	9540	Warsaw	
2045	7250	Vatican	
2100	4820	Bathurst	
2100	4965	Johannesburg	
2115	11860	Sackville	
2123	15265	R. Australia	
2200	4875	Johannesburg	
2211	4990	Lagos	
2245	4932	Benin City	
2245	4980	Ejura	

● **ANOTHER CLANDESTINE**

During the course of collating and writing this article, the writer has several times logged "The Voice of the Thai People" on a measured 9422.5 (31.83m) from 1510 through to sign-off around 1600. As would be expected, the programme is mostly composed of exhortations in Thai, alternately by male and female announcers, with short interludes of military music. At 1530 a series of chimes can be heard prior to identification. Sign-off varies from 1559 to 1605 when slogans are repeated several times followed by a short anthem or march-type tune.

● **60 METRE BAND DX**

Probably the broadcast band most favoured by the dyed-in-the-wool Dixer is that lying between the limits

4750 and 5060. Within these two frequencies are many low powered local service stations scattered throughout the world, the reception of most of them being difficult in the extreme. To spend any time at all with any hope of success on this band, quite apart from the propagation conditions existing at the time, one must perforce adopt an owl-like existence - much of the Dx being around between the time limits 2100 to 0430 or so. During the winter months, as a general rule, one can log the Far East from around 1500 through to 1630 but the band is best noted for the Latin American stations that abound, especially during the summer months. Some that we have recently logged are listed here.

● **BRAZIL**

4755 ZYF23 Radio Difusora do Maranhao, Sao Luis, with recorded dance music, European-style, announcements in Portuguese at 0108. This one signs-off at 0300 and is 5kW, quite often logged here in the U.K. (63.09m).

4805 ZYS8 Radio Difusora do Amazonas, Manaus, Latin American music, announcements in Portuguese at 0051. Closes at 0200, is 5kW, heard fairly regularly. (62.43m).

4886 ZYG26 Radio Pioneira de Teresina, with identification followed by talk in Portuguese at 2332. Listed 4885, this one has been heard as early as 2107 and can vary from 4885 to 4886.5 at times (we've measured it!). Closes at 0300 1kW (61.39m). Teresina is the capital of Piaul state.

● **VENEZUELA**

4810 YVMG Radio Popular, Maracaibo, featuring LA songs and music at 0210. Closes at 0300, can be heard when conditions are good for LA, 2kW (62.37m).

4830 YVOA Radio Tachira, San Cristobal, LA music after identification at 0247. Closes at 0400, can be heard when conditions are good, 1kW (62.11m).

4860 YVQE Radio Maracaibo, heard with talk in Spanish after station identification at 0215. Closes at 0400, logged quite often, 10kW (61.72m). Maracaibo is a seaport on the west bank of the narrow entrance to Lake Maracaibo (brackish, 60 miles wide, 120 miles long, oil wells on fringes and into lake bottom).

● **COSTA RICA**

4832 TIHB Radio Capitol, San Jose, talk in Spanish after station identification (quite often made during programmes) at 0015. This one has a 24 hour schedule, 1kW (62.08m), quite often heard here in the U.K. San Jose is the capital of Costa Rica.

● **DOMINICAN REPUBLIC**

5010 HIMI Radio Cristal, Santa Domingo, with LA songs and music after identification at 0200. HIMI has a 24 hour schedule and can be heard often at the time stated (and earlier), 1kW (59.88m).

Latin Americans are not, of course, the only stations that can be heard on the 60 metre band, how about -

● **CHINA**

4800 Radio Peking with talk in Chinese by YL at 2150 (62.50).

4815 Radio Peking signing-off with Internationale at 2355 (62.30m).

4833.5 Shenyang with YL in Chinese at 2124 (62.06m).

4905 Radio Peking with OM in Chinese at 2139 (61.16m).

4975 Foochow with OM and YL alternately in Chinese (60.30m).

RECEIVER BOARD

The receiver components are wired on a piece of plain Veroboard (i.e. without copper strips) of 0.15 in. matrix. If this is cut to have 20 rows of holes one way and 6 rows the other, components can be located exactly as in Fig. 2. With the speaker and case used by the author, a rectangular cut-out is needed to clear the speaker. The position and dimensions of the cut-out, relative to the Veroboard holes, can be judged from Fig. 2. A 6BA clear mounting hole has to be drilled before any components are mounted on the board.

Begin by inserting Veroboard pins at positions 1 to 8, then fit the capacitors, noting the polarity of C4, C5 and C9. The component lead-outs pass through the board to make connections underneath, as illustrated in Fig. 2. Put insulated sleeving on any leads which may touch other leads or joints, and snip off excess wire.

After the resistors and capacitors are fitted, it is advisable to check the wiring around R4 and R5 to ensure that there is no risk of applying excessive voltage to the ZN414. Connect a high resistance voltmeter, or a testmeter switched to a suitable voltage range, across R4, and apply a 9 volt battery to Veroboard pins 4 and 7 with positive to pin 7. The meter should indicate about 1.4 to 1.5 volts. If the voltage is higher, the connections to R4 and R5, together with their values, must be checked and the error rectified before proceeding further.

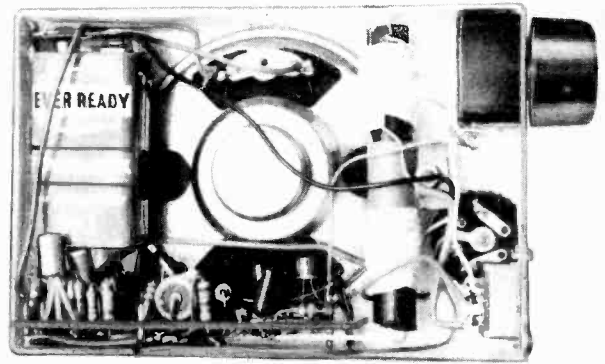

A view inside the receiver case. The components fit comfortably around the loudspeaker without excessive crowding

Next fit the ZN414 and the three transistors. Extension wires may be soldered to the lead-outs of TR1 and passed through the Veroboard holes. Make sure the four semiconductor components are all wired correctly and put sleeving on their leads if there is any risk of short-circuits. Solder in the usual way for semiconductors: it should only be necessary to hold the iron in contact with the joint for a few seconds. Lengthy heating may cause damage.

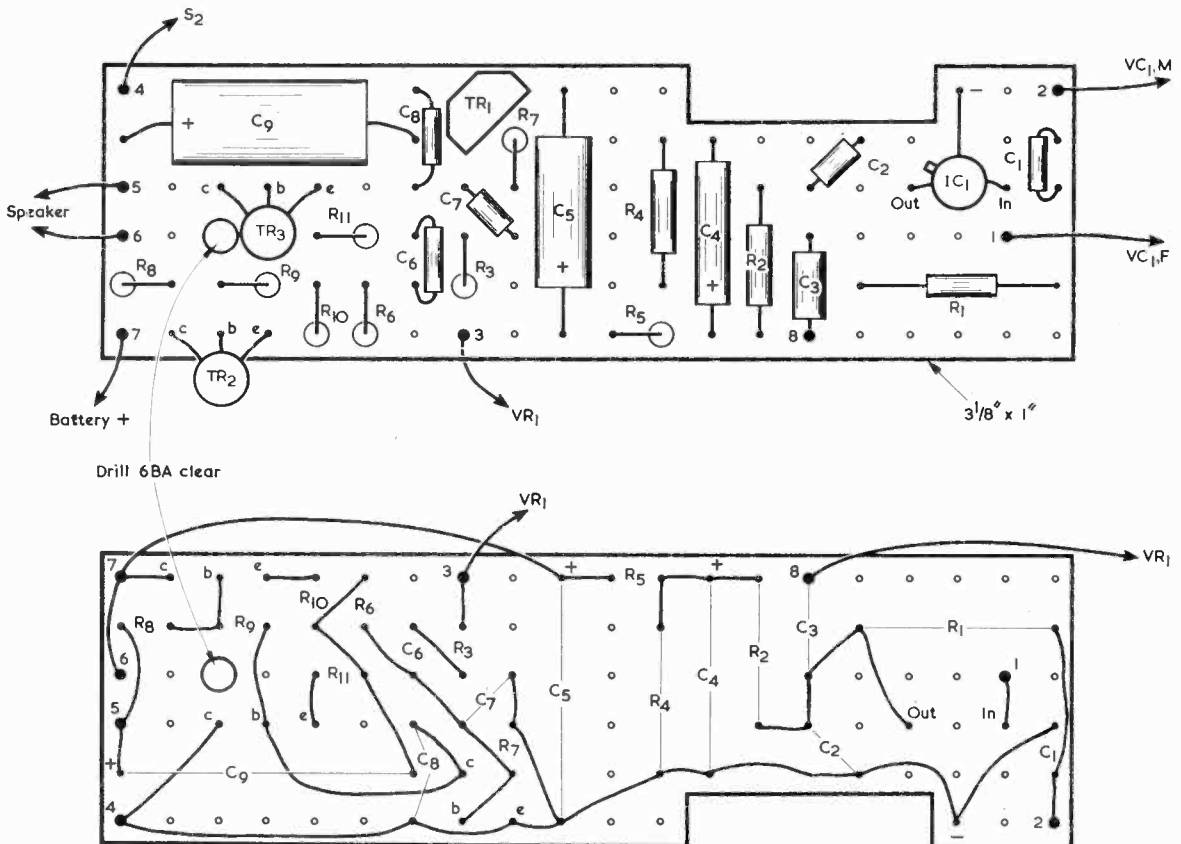
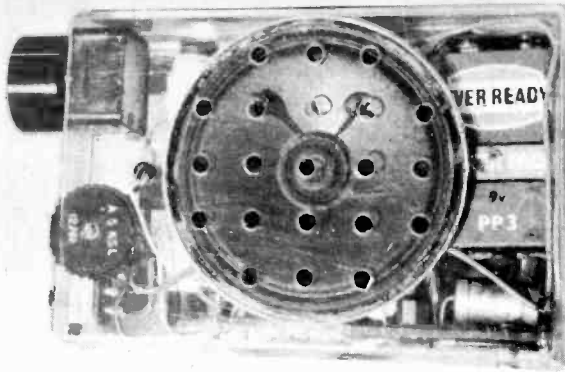

Fig. 2. Details of the circuit board. The component side appears in the upper section and the underside in the lower section of the diagram



This all-revealing view shows the prototype receiver before its cabinet was painted

CASE PREPARATION

Transparent plastic boxes of the type used for the prototype seem quite strong, but they will crack whilst making holes if the drill is forced. There is no danger of this if the drill is sharp and is applied with fairly light pressure.

The speaker fits behind five rows of $\frac{1}{8}$ in. or $\frac{3}{16}$ in. holes in the bottom of the box, which now becomes the front panel of the receiver. Slots for the slide switch and for VR1 are made by drilling one or two small holes to allow the introduction of a file. The slots are then gently filed out until these parts fit correctly. VC1 requires a hole for its spindle and two holes for the small short bolts provided.

If of the type used by the author, VR1 is fixed to the front panel with a small bolt. Other types of potentiometer may be mounted in the manner just described. VC1 and S1 can also be fitted at this stage. If the speaker is of the type quoted in the Components List it will have a rim which can be smeared with adhesive (such as clear Bostik 1). The speaker can then be put in position and left until the adhesive sets.

FERRITE ROD

The ferrite rod aerial is wound as in Fig. 3. Begin L1 about $\frac{1}{4}$ in. from one end of the rod at 'A' and wind 60 turns of 26 s.w.g. d.c.c. or d.s.c. wire in a pile which is about $\frac{3}{8}$ in. long. Leave a space of about $\frac{3}{8}$ in. and wind on 150 turns of 34 s.w.g. s.s.c. or enamelled wire for L2, in the same direction as L1 so that the two coils, when connected in series, are mutually aiding. L2 is wound in a pile similar to L1. The turns may be held in position by a touch of adhesive at the ends, or by adhesive tape. Solder the adjacent ends of L1 and L2 together, to provide point 'B'. The finish of L2 is lead 'C'.

A $\frac{3}{8}$ in. 6BA bolt passes through a hole drilled in the front panel of the case, and through a strip of card passed round the rod. Extra nuts, or a spacing pillar,

Fig. 3. Layout of the components inside the case

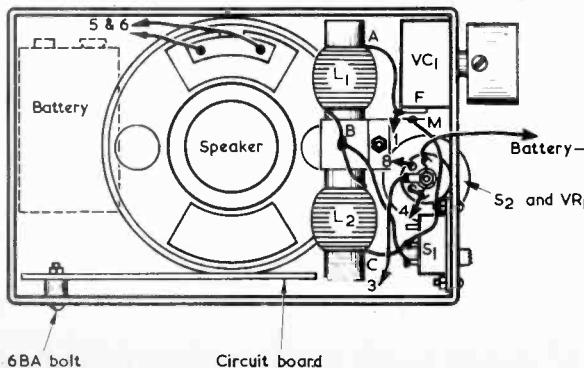

cause the rod to be held about $\frac{1}{2}$ in. away from the rear surface of the front panel.

Connect lead 'A' to the fixed vanes tag, 'F', of VC1. Point 'B' connects to one tag of S1 and lead 'C' of the other tag. Lead 'C' then continues to the moving vanes tag, 'M', of VC1. Only two of the tags available on S1 are used; the remaining tag (or tags) is ignored.

BOARD FIXING

A 6BA bolt with a spacing pillar or extra nuts holds the circuit board in the position shown in Fig. 3, with the ZN414 adjacent to L2. The location of the hole required in the case side is marked off with the aid of the board itself. The spacing between the board and the inside of the case side need only be sufficient to provide clearance for the wiring under the board.

The following wiring steps are next carried out. Connect pin 1 of the board to the fixed vanes tag, 'F', of VC1. Connect pin 2 to the moving vanes tag, 'M', of VC1. Connect pin 3 to the slider of VR1. Connect pin 4 to the low-volume end of VR1 track, and continue the lead to one tag of S2. Connect pins 5 and 6 to the speaker. Connect pin 7 to the battery positive clip using thin red flexible wire. Connect pin 8 to the high-volume end of VR1 track. Using thin black flexible wire, connect the remaining tag of S2 to the negative battery clip.

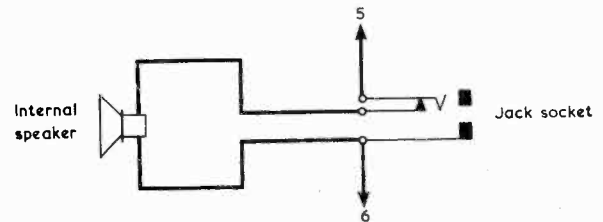

Fig. 4. If desired, an earphone jack socket may be added. It is wired up in the manner shown here

USING THE RECEIVER

There is no means of adjusting frequency coverage except by moving L1 or L2 on the ferrite rod (assuming these are initially wound on paper sleeves) or by changing the number of turns in these windings. Normally, there should be no need for any adjustments whatsoever.

The audio output of the receiver should be at the level given by the usual type of small pocket portable radio, and quality should be good. A current-reading meter inserted in one of the battery leads should indicate a current consumption of about 10 to 12mA, this rising a little at maximum volume. In difficult situations, the effect of rotating the receiver to take advantage of the directional aerial should be tried.

Since a small receiver of this kind is excellent for personal listening, an earphone outlet may be added, if desired. A suitable circuit for a miniature 2.5 mm. or 3.5 mm. switched jack socket is given in Fig. 4, and this causes the speaker to be silenced when the jack plug is inserted. The jack socket is an optional extra, and is not included in the Components List. It may be positioned near VR1. It will be found that a complete headset of about 100Ω will give excellent results, and headsets of this type can sometimes be obtained as inexpensive surplus. A single earpiece may also be employed, or a headset of 30Ω to 500Ω. Earphones with an impedance of less than 30Ω should not be used. ■

FINAL NOTES

ON

CYCLOPS

by
L. C. Galitz

In this concluding article our contributor discusses possible additions to robots such as Cyclops.

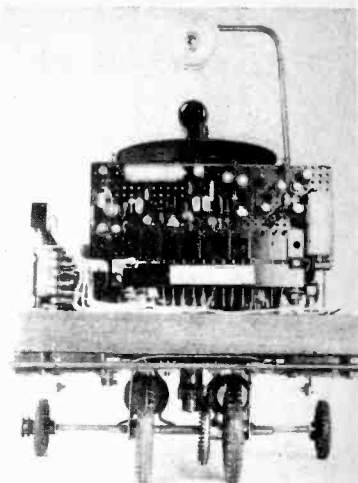

THE PREVIOUS ARTICLES ON CYCLOPS* dealt with constructing a robot using a design which has been proven to work. In this article suggestions are made for possible improvements, although exact details are not given. These suggestions, it is hoped, will provide food for thought and may fire the imagination of some constructors to go even further than the ideas outlined here.

FURTHER STIMULI

Cyclops, in his present condition, can learn only one thing at a time. If, when he is programmed to learn to carry weights, a set of meaningful stimuli are presented to him which are not directly concerned with load-carrying, he will ignore them.

This is obviously a disadvantage, and the way to solve this problem is to construct several circuits to the design of the present Board 2, excluding the circuitry around TR15 and TR16 except where needed, and wiring the inputs of these separate conditioned reflex units directly to the input stimuli presented to the switching unit, then removing the switch altogether. This means that the set of meaningful stimuli, say for conditioning to touch, is permanently connected to a conditioned reflex unit, and thus Cyclops

*CYCLOPS - Cybernetically Controlled Light Orientated and Powered System' Parts 1 to 6, *Radio & Electronics Constructor*, July 1972 to December 1972. 'Modifications To Cyclops', *Radio & Electronics Constructor*, April and May 1973.

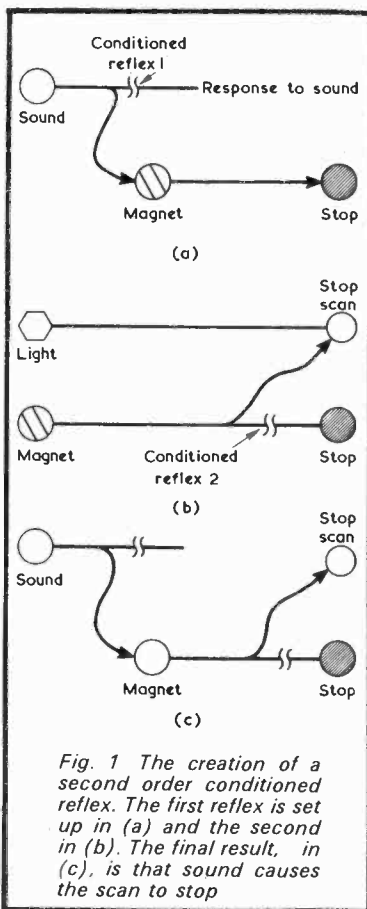

Fig. 1 The creation of a second order conditioned reflex. The first reflex is set up in (a) and the second in (b). The final result, in (c), is that sound causes the scan to stop

is always prepared to establish a meaningful conditioned reflex.

SECOND ORDER REFLEX

Having several conditioned reflex units active simultaneously means that it is feasible to establish second order reflexes, or even third order reflexes, as outlined in Part 5 of the 'Cyclops' series (published in the November 1972 issue).

If, as we shall see later, we introduce a sound sense, we could condition Cyclops such that sound means magnet, so stop. If we then establish the existing conditioned reflex, that magnet means food, so 'home' into magnets, then, if we make a sound, we will find that Cyclops will cease scanning as if to home into the sound. This is exemplified by Fig. 1 which shows this second order reflex in diagrammatic form.

MORE SENSES

Cyclops at present has five senses, namely light, touch, presence of magnets, presence of loads, and a sense which detects when he is moving. In order to make him a more versatile animal, more senses are necessary.

In human beings, there are also five recognised senses: those of sight, hearing, smell, taste and touch, the latter incorporating a temperature sense as well as a general touch sensing mechanism. Out of these, it would be quite an improvement if hearing were added to Cyclops' sensory repertoire.

AUDITORY SENSING

Auditory sensing is more difficult to synthesize than is realized. The human ear can detect amplitude, phase, and thus direction; pitch (to a very high degree of accuracy); and can analyse several incoming audio signals and, in conjunction with the brain, separate out the one which is significant.

It would obviously be impossible to simulate anything approaching this complexity without the generous use of digital computers, and so a suggested auditory sense for Cyclops would be such that he could detect the presence of two different tones.

Two alternative methods of doing this will next be described. The first uses filters, whereas the second uses a digital counting technique. The advantage of the former method is that the circuitry can work correctly even when both tones are broadcast simultaneously, but it requires several amplifiers. The second method uses a more digital technique, and can be expanded very easily, but will not give an output if more than one tone is broadcast.

Reference to Fig. 2 shows that the

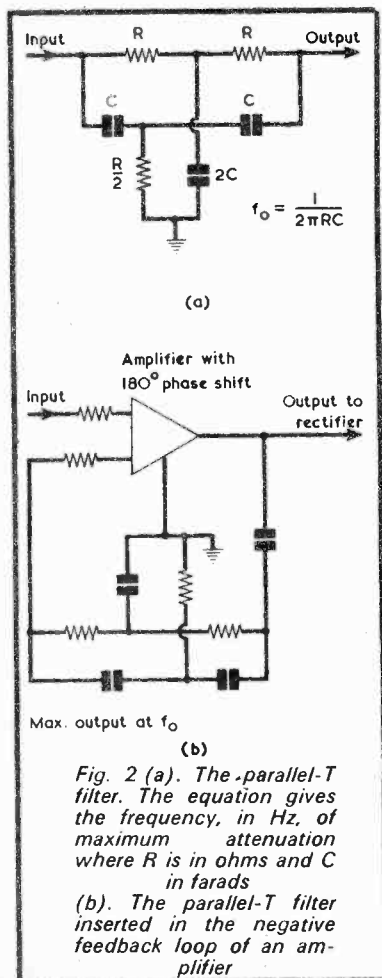

Fig. 2 (a). The parallel-T filter. The equation gives the frequency, in Hz, of maximum attenuation where R is in ohms and C in farads
(b). The parallel-T filter inserted in the negative feedback loop of an amplifier

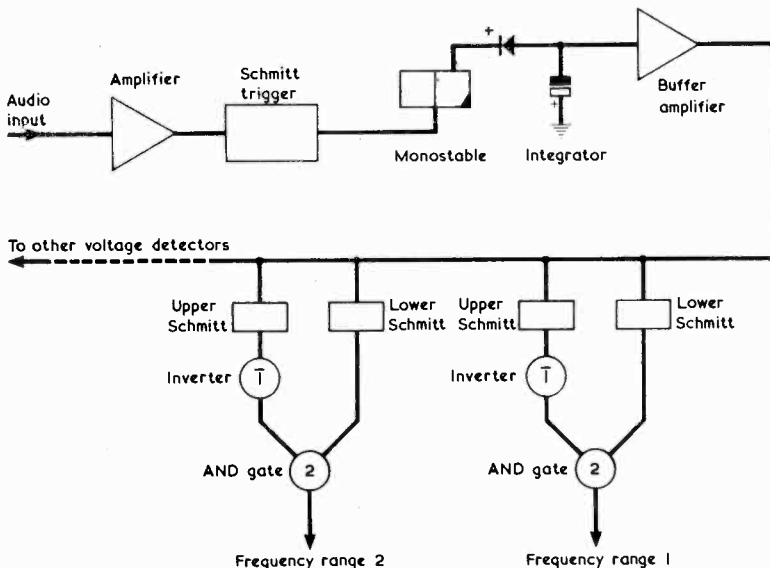

Fig. 3. Another method of obtaining response at one or more specific audio frequencies

heart of the first method lies in the use of a parallel-T rejection filter incorporated in the feedback loop of an amplifier. Little negative feedback from amplifier output to input is provided at the frequency at which the filter offers greatest attenuation, and the amplifier offers a high gain at this frequency. On the other hand the feedback level is high at frequencies that are some way removed from the filter frequency and the amplifier gain is low at these frequencies. This means that the amplifier-filter combination output is high at the maximum attenuation frequency of the filter and is low at others. The output can thus be rectified and smoothed, then fed to a Schmitt trigger, whereupon the output of the latter will be high at the filter frequency and low at other frequencies.

The second system amplifies the input signal, squares it with a high-speed Schmitt trigger, and feeds the pulses from this to a high speed monostable, whose quasi-stable period is shorter than the period required for one cycle of the highest frequency signal to be detected. The output of the monostable passes via a diode to a capacitor which integrates the incoming pulses to give a mean direct voltage output. The voltage on the capacitor is dependent on the frequency of the input, because the greater the input frequency, the greater the number of monostable pulses.

The output from this capacitor is amplified by a buffer and fed to several voltage detectors, which detect when a voltage is within a certain range. This is accomplished by having two Schmitt triggers at each detector. One trigger is

set to the level of the voltage at the bottom end of the desired range, and the other is set to the voltage at the upper end of the range. The output of the latter Schmitt trigger is inverted, so that in the range required, a logic 1 exists on the lower threshold Schmitt, and a logic 1 also exists after the inverter connected to the higher threshold Schmitt. It merely remains to take these two outputs to an And-gate, whose output will then be at logic 1 when the voltage presented to the Schmitts is in the desired range. Any number of voltage detectors can be placed after the buffer amplifier, each detecting a certain voltage range, and thus, a certain frequency range. This method is displayed pictorially in Fig. 3.

LOCATION OF AUDIO SOURCES

The audio frequency detectors just described detect only the presence of an audio signal and not its location. The human ear and brain uses a combination of factors for determining the position of sounds. These factors are phase and amplitude, and the brain, taking into account a complicated analysis of all the reflections, resonances and distortions of the original sound, comes up with what is usually a highly accurate answer as to the position of the original sound.

Our technique for recording stereo sound is to use a pair of microphones with suitable polar responses, placed one above the other at right angles to each other. This approach, known as the Blumlein technique, is illustrated in

Fig. 4, and could be adapted for use in a robot similar to Cyclops.

If a pair of these microphones are mounted on the scanning head, the outputs being fed to a differential amplifier, these outputs will be identical when the sound source is on the axis of symmetry of the microphones, causing the output from the differential amplifier to be zero. The sound source will thus be either directly in front of the microphones, or directly behind. To eliminate the latter possibility, some sound-absorbing material, such as a wad of glass fibre, could be placed directly behind the microphone combination, to ensure that there would be no ambiguity as to the direction of the sound once the differential amplifier output was zero.

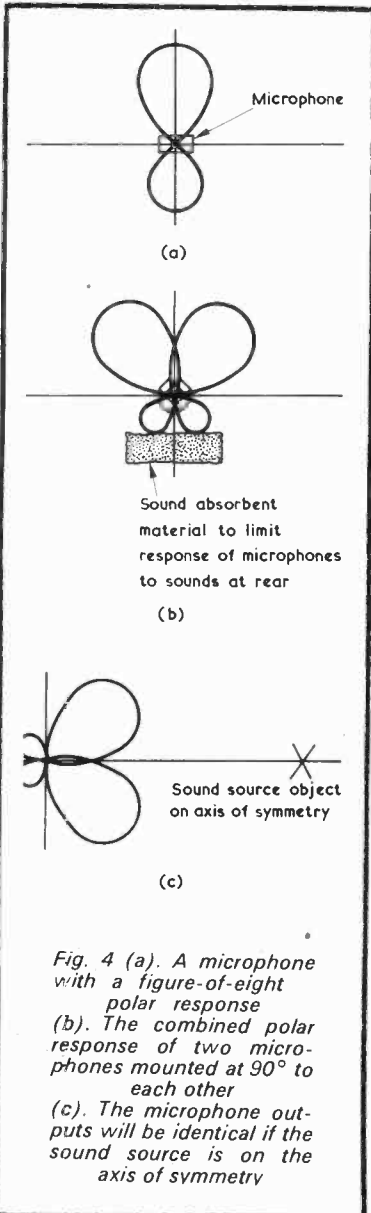

FEATURED NEXT MONTH

MINIATURE THREE CHANNEL MIXER

by R. A. Penfold

A completely self-contained 3 channel audio mixer which provides nominal input impedances of 50k Ω , 500k Ω and 1M Ω . An integral amplifier is incorporated.



CASSETTE RECORDER MAINS UNIT

by S. Essex

A simple stabilized power unit suitable for use with battery operated cassette recorders requiring supplies of 6, 7.5 or 9 volts.



RANDOM OUTPUT GENERATOR

by E. F. Whitman

The device can be described as a complicated method of tossing a coin!

It is an amusing gadget which can be made up into a small pocket unit complete with its own battery.

PLUS

MANY OTHER ARTICLES

Price 20p

ON SALE 1st JULY

ORDER YOUR COPY NOW

**RADIO & ELECTRONICS
CONSTRUCTOR**

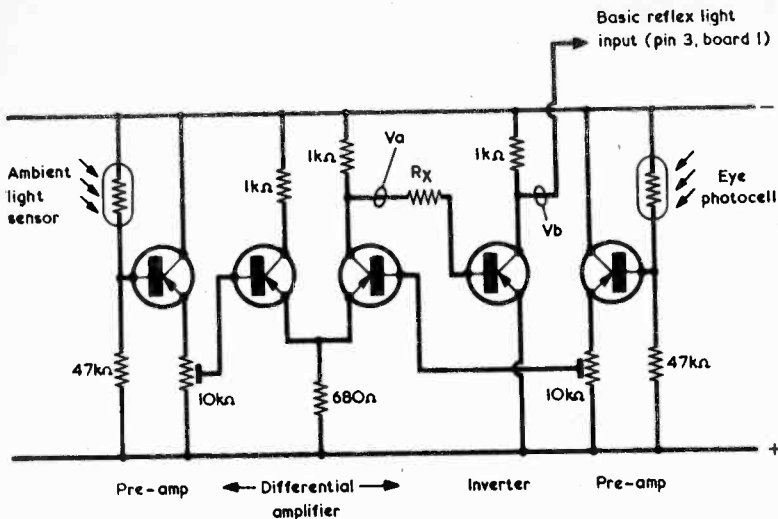

Fig. 5. An experimental circuit which enables Cyclops to recognise light levels higher than ambient

If the output from this system were inverted, such that when a sound was heard on the axis of symmetry a logic 1 would be present on the inverter output, the resulting system would be exactly analogous to the light detecting

system already incorporated in Cyclops. By connecting this system into the basic reflex circuitry, a robot similar to Cyclops could be made to home into sound sources as well as into light sources.

DIFFERENTIAL LIGHT INPUT

At present Cyclops monitors only the absolute light level and thus, if put in a room which is uniformly brightly lit, he would sit in the centre of the floor doing absolutely nothing. Admittedly he would be theoretically recharging his batteries all the time, but it would not be a very interesting life! What would be more useful would be a device by means of which he detects the difference in ambient light level and the light level of the area he is looking at. This could easily be accomplished by having the existing photocell connected to one input of a differential amplifier, and a second photocell, covered with frosted glass and placed anywhere else in Cyclops' anatomy, connected to the other input of the differential amplifier. See Fig. 5. The output of the differential amplifier passes to the input of the basic reflex circuitry.

Now, Cyclops will only home into light sources brighter than his habitat's ambient lighting, and will not have any interest in anything else.

In Fig. 5 the preset variable resistors should be set up such that V_b increases only when the light input on the eye photocell is greater than the light on the ambient light sensor. Also, R_x should have a value such that V_a plus V_b is approximately equal to the supply voltage for all values of V_a . R_x was made $100k\Omega$ in an experimental circuit, and it was found that V_a plus V_b was then always within $0.2V$ of the supply voltage.

ADVANCED RECOGNITION

At present, Cyclops' self-recognition circuit requires either a fairly powerful bulb, drawing consequently quite a heavy current from the battery, or a dimmer bulb and the necessity to hold a mirror very close to the eye to enable Cyclops to 'see' himself.

One way to get round this problem is to use light modulation. If the recognition lamp is pulsed with light at around $10Hz$, then it can be fairly powerful, yet the mean level of power drawn from the battery can be relatively small if the mark-space ratio is fairly low. Fig. 6 shows details of a theoretical system. Furthermore, the output from TR2 (on Cyclops Board 1) can be amplified by another circuit to quite a great extent, and compared with the signal from the lamp modulation circuit. If the two agree then it means that Cyclops can see his recognition lamp and suitable action can be taken. The reason for having a large amount of amplification after TR2 is that this enables even a weak light signal to operate the comparator circuit, the latter giving an output when the two inputs match. Thus, Cyclops will be able to see his reflection quite a long distance away without causing excessive drain on his batteries through using too powerful a recognition lamp.

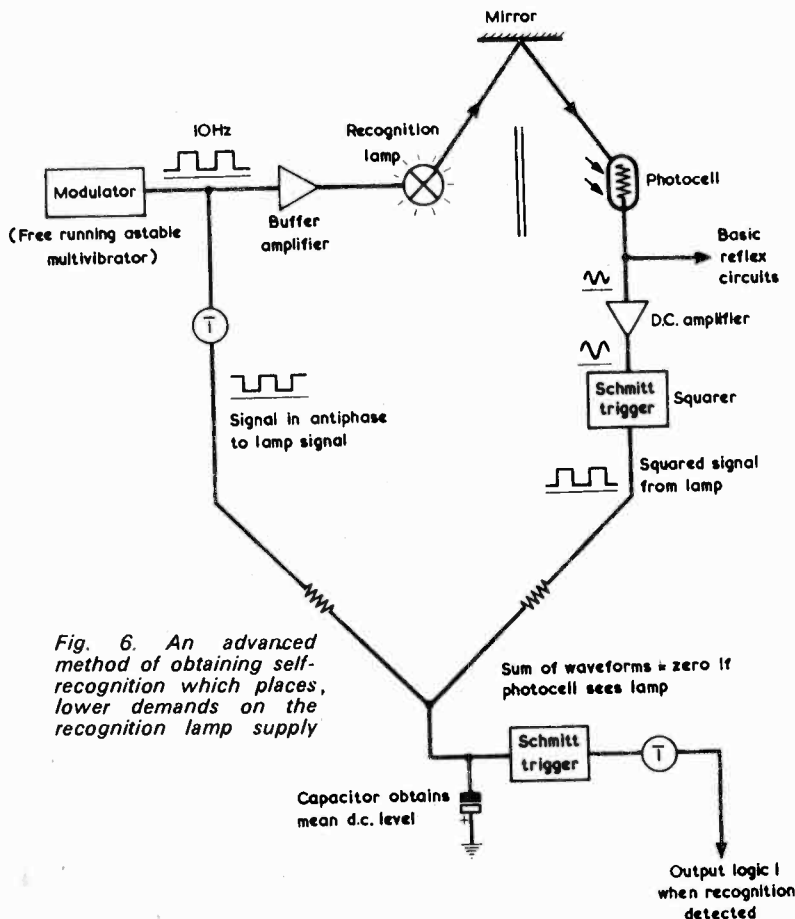

Fig. 6. An advanced method of obtaining self-recognition which places, lower demands on the recognition lamp supply

FINDING BIAS RESISTANCE VALUES

by

J. R. Davies

By making several simplifications, it becomes an easy matter to select bias resistors for small signal silicon transistor circuits.

TWO POPULAR METHODS OF EMPLOYING SMALL SIGNAL silicon transistors consist of operating them in the emitter follower mode with a single bias resistor coupling to the upper supply rail, and in the common emitter mode with a single bias resistor returned to the collector. The values selected for the bias resistor in both these methods of operation is often the result of a 'guesstimate' so far as the amateur experimenter is concerned, and the bias resistor value employed may not in many cases be that which offers optimum results. It is, however, possible to find the value of bias resistor required for most applications of these basic circuits in quite a simple and reliable manner. A further advantage of the method to be described is that the bias resistor selected caters for very wide spreads in h_{FE} .

CALCULATION APPROACH

Fig. 1 shows the first of the two circuits. The transistor in this diagram is operated in the emitter follower configuration, with R_2 as the emitter load and R_1 as the bias resistor. What is the value required in R_1 ?

We start by making three assumptions. We assume first that the voltage drop in the base-emitter junction of the transistor is zero. Second, we assume that the current gain of the transistor, which is the number of times that the emitter current is greater than the base current, is equal to its h_{FE} value. And third, we assume that we are going to operate the circuit such that, with a transistor having an h_{FE} which is 'central' within its spread, the standing voltage at the emitter is equal to or close to half the supply voltage.

The first of our assumptions causes us to dismiss the fact that, in practice, there is a drop of about 0.6 volt across the base and emitter of a conducting silicon transistor. As we shall see shortly, it is safe to ignore this voltage drop provided that the supply voltage is reasonably high. Our second assumption, that the current gain is equal to h_{FE} , introduces a slight inaccuracy because the current gain of an emitter follower is equal to $h_{FE} + 1$.

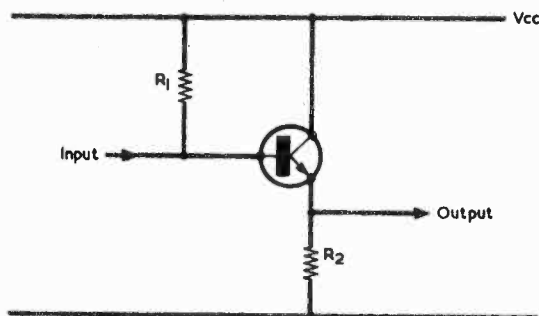

Fig. 1. The basic emitter follower circuit. There will normally be series capacitors at the input and output, but these are not shown here

The '+ 1' term arises from the fact that the base current flows in the emitter load resistor in addition to the collector-to-emitter current. But the average silicon transistor has a spread in h_{FE} in which the maximum figure is considerably greater than three times the lowest value. When dealing with figures which range as widely as these, the inaccuracy introduced by ignoring the '+ 1' term is minimal. The third assumption, that the standing emitter voltage for a transistor with a 'central' h_{FE} value is equal to or close to half the supply voltage, represents a good approach in simple amplifier design. When the emitter is at half the supply potential it is capable of maximum voltage swing in both directions.

In Fig. 1, therefore, we have, after taking up our first and third assumptions, the situation where both the lower end of R_1 and the upper end of R_2 are at a potential which is half the supply potential. In consequence, an equal voltage is dropped across each

resistor. Now, since the current gain in our transistor (from assumption number 2) is equal to h_{FE} , then the current in R_2 is equal to that in R_1 multiplied by h_{FE} . It follows that, for equal voltages across each resistor, the value of R_2 must be that of R_1 divided by h_{FE} . Or, put another way, that R_1 is R_2 multiplied by h_{FE} .

In actual fact, this set of circumstances will not cause the emitter of the transistor to be exactly at half supply voltage because we have purposely ignored the fact that in a practical silicon transistor there is a drop of 0.6 volt across the base-emitter junction. So the practical result of making R_1 equal to R_2 multiplied by h_{FE} will be that the emitter is 0.3 volt below the half supply voltage level and that the base is 0.3 volt above the half supply voltage level. These discrepancies should not be of great significance provided that the supply voltage is of the order of 3 volts or more.

Maintaining the assumption that there is zero voltage drop across the base-emitter junction of the transistor, the circuit of Fig. 1 can be redrawn in the manner shown in Fig. 2, where we have introduced a new

resistor, R_x , to represent the resistance 'seen' by the lower end of R_1 as it 'looks' into the base of TR2. R_x is equal to R_2 multiplied by h_{FE} . We can now go a stage further. The voltage across R_x (which is the emitter voltage of the transistor) is equal to

$$\frac{R_x}{R_1 + R_x}$$

of the supply voltage.

PRACTICAL EXAMPLES

We now proceed to a practical example. Let us say we have a silicon transistor which is specified by the manufacturer as having a minimum h_{FE} of 100 and a maximum h_{FE} of 400. Our supply voltage is 10 volts and we want the standing emitter current to be about 2mA.

Since the emitter will be at half the supply voltage, this sets up the emitter resistance value straightaway. A current of 2mA at 5 volts will flow in a resistance of 2.5k Ω . In practice we will use a near preferred value, which can be either 2.4k Ω or 2.7k Ω . Let us arbitrarily choose 2.7k Ω , which value is shown in Fig. 3(a). We next select a 'central' h_{FE} figure within the spread of the transistor which will also enable the circuit to function adequately with transistors having the minimum and maximum h_{FE} values. The 'central' figure we will choose is not the value which lies half-way between the lower and upper h_{FE} figures, but is one which is about a third of the way up from the lower figure. (The reason for this choice will become clear soon.) The h_{FE} value which is a third of the way up from the lower h_{FE} figure of 100 is 200, whereupon we next say that R_1 should be 2.7k Ω multiplied by this figure. 2.7k Ω multiplied by 200 works out at 540k Ω , and we could in practice use a 560k Ω component. Thus, with the emitter load R_2 at 2.7k Ω and the bias resistor R_1 at 560k Ω we have achieved conditions where the emitter current is close to 2mA and where, with a 200 h_{FE} transistor, the emitter voltage is close to half the supply voltage.

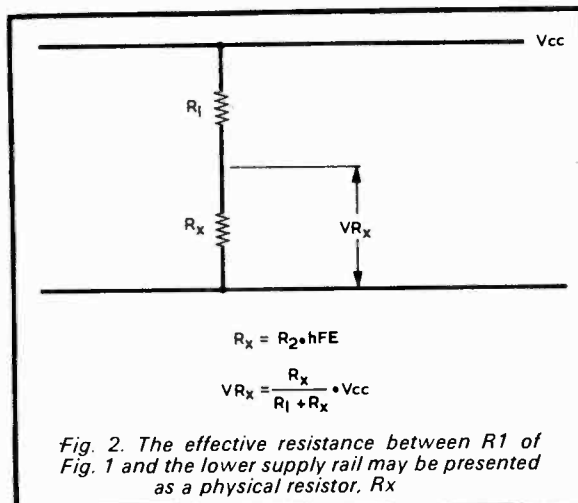

Fig. 2. The effective resistance between R_1 of Fig. 1 and the lower supply rail may be presented as a physical resistor, R_x

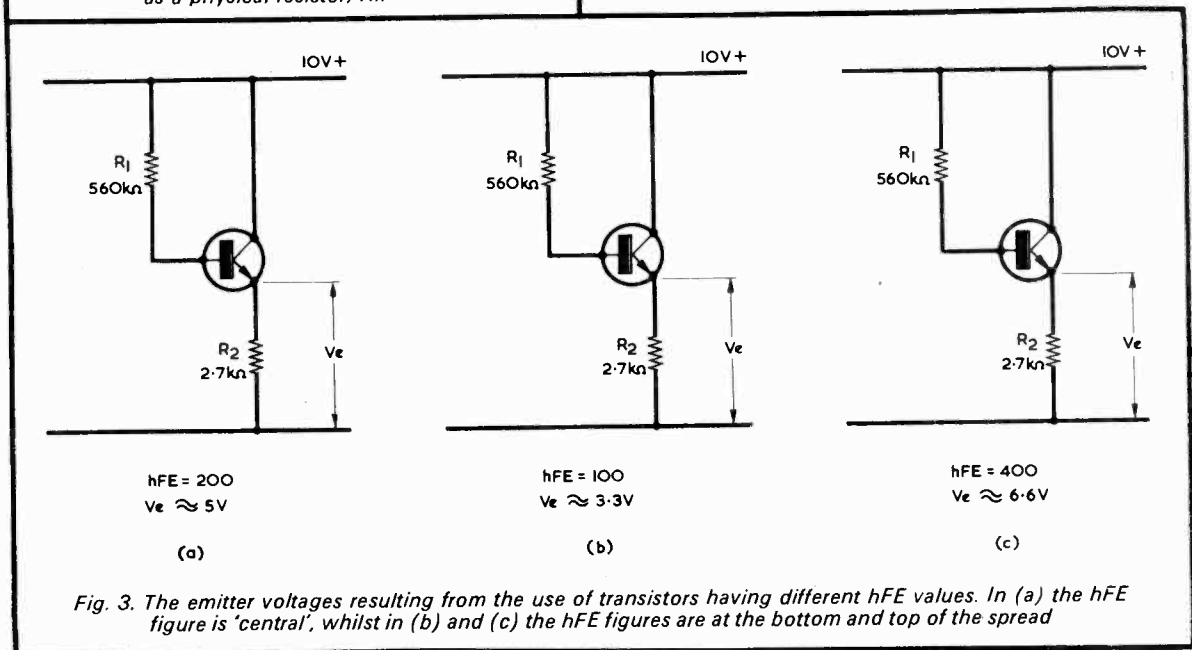

Fig. 3. The emitter voltages resulting from the use of transistors having different h_{FE} values. In (a) the h_{FE} figure is 'central', whilst in (b) and (c) the h_{FE} figures are at the bottom and top of the spread

Let us now see what happens with transistors which have the bottom and top hFE values in the spread. To find what occurs here we return to Fig. 2 and find the voltage across Rx for the two outside spread figures. For an hFE of 100, the effective value of Rx is 100 times 2.7kΩ, or 270kΩ, and the voltage across it (working in terms of kilohms) is therefore

$$270$$

$$\frac{560 + 270}{1,080}$$

of the supply voltage of 10 volts. This is 3.3 volts, as indicated in Fig. 3(b). With an hFE at the upper limit of 400, as in Fig. 3(c), Rx has an effective value of 2.7kΩ multiplied by 400, which is 1,080kΩ. The fraction of the supply voltage across Rx now becomes

$$1,080$$

$$\frac{560 + 1,080}{1,080}$$

The result is 6.6 volts, as illustrated in Fig. 3(c). So, when the transistor has an hFE of 100 the emitter voltage is about 3.3 volts, and when it has an hFE of 400 the emitter voltage is about 6.6 volts. Both these voltages are nicely symmetrical about the half supply voltage figure and the results show that the transistor emitter is left with nearly the maximum voltage swing it can be offered even when its hFE is at its lowest or at its highest rated value.

These results also explain the apparent anomaly of choosing, as a 'central' hFE figure for the initial calculation, a value which is not exactly centred between the two outside hFE figures but one which is about a third of the way up from the lower one. The variation of emitter voltage with hFE is not linear, and the process of choosing a 'central' figure which is about a third of the way up satisfies the distribution in the final results without incurring complicated mathematics.

To sum up the procedure involved in determining the desired base bias resistance for the circuit of Fig. 1, we first of all choose an emitter resistor which will cause the desired emitter current to flow when the emitter is at half the supply voltage. We next check on the spread of hFE figures quoted by the transistor manufacturer, select as a 'central' figure one which is about a third of the way up from the lower hFE limit and then fit a base bias resistor which is equal to the emitter resistor multiplied by this 'central' value. Naturally, in a practical world we choose a near preferred value and work, in most instances, with 10% resistors. There is no necessity to calculate the emitter voltages for the lower and upper hFE figures; this procedure was carried out here for purposes of demonstration only.

COMMON EMITTER CIRCUIT

We next turn our attention to the common emitter circuit shown in Fig. 4. In this case, R2 is the collector load resistor whilst R1 is the bias resistor. Once more we make three assumptions. The first of these is that there is zero voltage drop across the base-emitter junction of the transistor. The second is that the current flowing in R2 is equal to the current flowing in R1 multiplied by the hFE of the transistor. Actually, the current in R2 is equal to that flowing in R1 multiplied by hFE + 1 since the current for R1 also flows in R2. But we can, as before, ignore the '+ 1' term. And finally, we assume that the desired output condition is given when the collector of a transistor having a 'central' hFE value is at a potential equal to half the supply voltage.

The circuit of Fig 4 can be resolved to that of Fig. 5 in

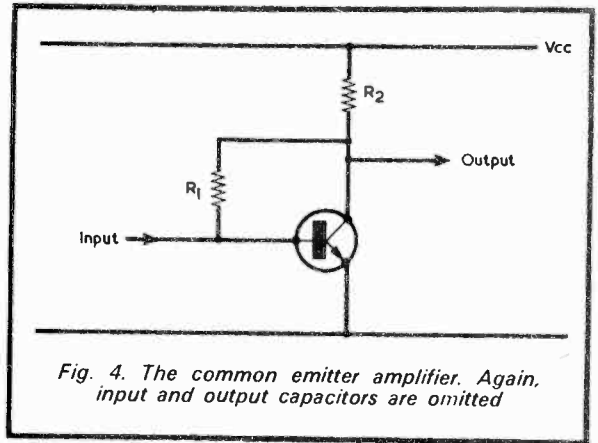

Fig. 4. The common emitter amplifier. Again, input and output capacitors are omitted

which Ry represents the effective resistance above R1. Ry is equal to R2 multiplied by hFE.

The resistor arrangement in Fig. 5 is that of Fig. 2 turned upside down, since the resistance equal to R2 multiplied by hFE is now at the top and R1 is at the bottom. The voltage across R1, and hence the collector voltage for the transistor is equal to

$$R1$$

$$\frac{R1}{Ry + R1}$$

of the supply voltage. Despite the change in the fraction the 'central' hFE figure we select from the spread is still one third up from the bottom figure in the range.

To take an example let us next say that the transistor we are to use has an hFE spread of 250 to 900 and that we want collector current to be about 3mA. The supply voltage is 10 volts, as before, and the resistance required for a flow of 3mA at 5 volts is 1.7kΩ. In practice, we can use the near preferred value of 1.8kΩ. The 'central' hFE figure one third up between 250 and 900 turns out to be 467. There is no point in working to as exact a value as this and it will be in order to choose 450 as the 'central' value. This results in R1 requiring a value of 1.8kΩ multiplied by 450, or 810kΩ. We can choose a preferred value of 820kΩ.

Thus, with R2 at 1.8kΩ and R1 at 820kΩ, a transistor with an hFE of 450 has its collector close to half supply

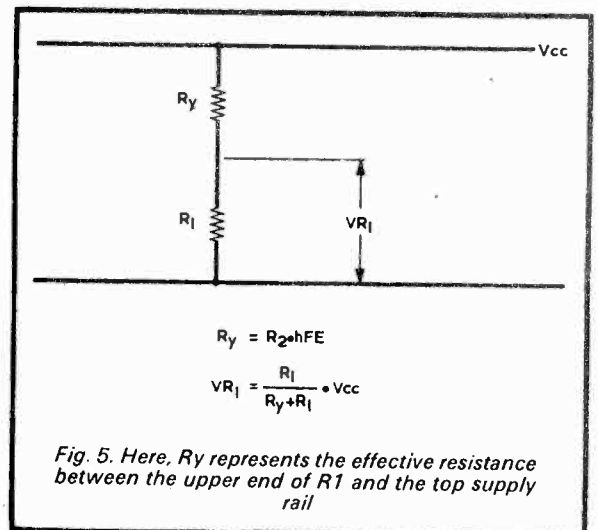

Fig. 5. Here, Ry represents the effective resistance between the upper end of R1 and the top supply rail

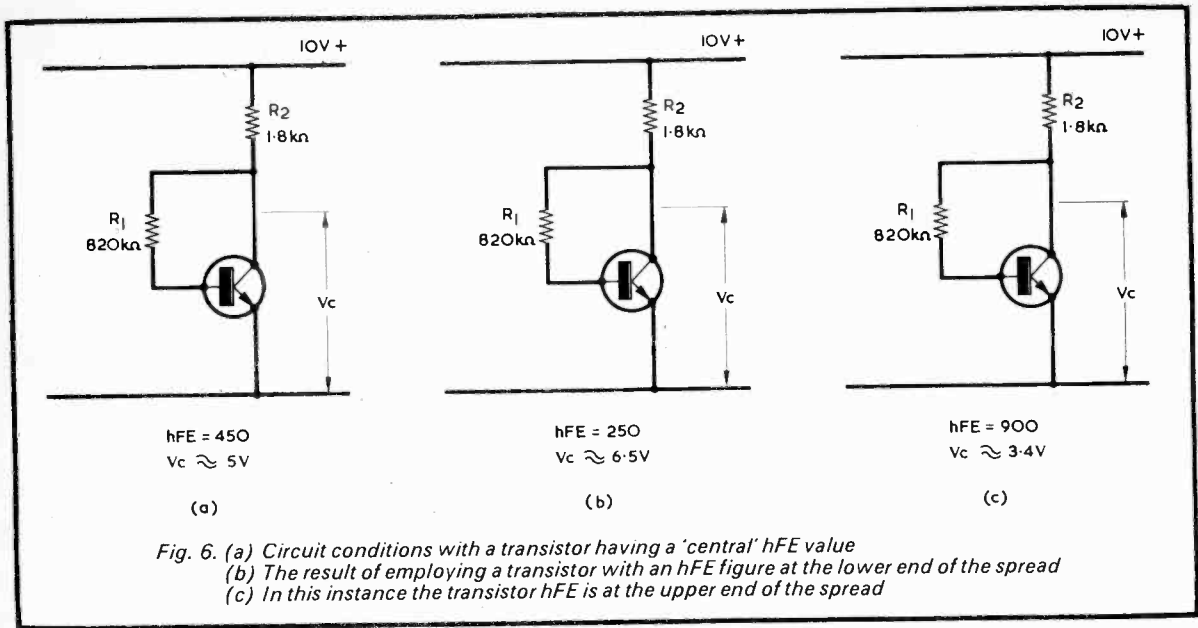

Fig. 6. (a) Circuit conditions with a transistor having a 'central' hFE value
 (b) The result of employing a transistor with an hFE figure at the lower end of the spread
 (c) In this instance the transistor hFE is at the upper end of the spread

voltage. These circumstances are shown in Fig. 6(a). Actually, the collector voltage will be 0.3 volt higher than its calculated value because we have chosen to dismiss the 0.6 volt drop in the base-emitter junction of the transistor. Again, for supply voltages of 3 volts or more, we can ignore this discrepancy.

We can now, to see that we are obtaining the best results from our transistor, check the collector voltages which occur at the two extremes of hFE. At the bottom hFE figure of 250 the effective value of R_y ($1.8k\Omega$ multiplied by 250) is $450k\Omega$, so our fraction becomes

$$\frac{450 + 820}{1,620 + 820}$$

The consequent collector voltage then works out at 6.5 volts. See Fig. 6(b). (We can expect the collector voltage to rise with reduced hFE because the collector then draws less current through R_2 .)

With hFE at the top limit of 900, the value of R_y ($1.8k\Omega$ multiplied by 900) changes to $1,620k\Omega$ and the collector voltage becomes

$$\frac{820}{1,620 + 820}$$

of the supply potential. As indicated in Fig. 6(c), this calculates out at 3.4 volts. As can be seen, our design approach has resulted in an almost exactly symmetrical voltage change on either side of the half supply figure, despite a very wide spread in hFE of 250 to 900.

Summing up the situation with the common emitter circuit, we approach the selection of the bias resistor in the following manner. We first choose a collector load resistor which will pass the desired collector current at

half the supply voltage. We then check the hFE spread figures for the transistor and select a 'central' figure which is about one third of the way up from the low end of the range. The value of the base bias resistor is then the nearest preferred value to the collector load resistance multiplied by the 'central' hFE figure. In this article we have also checked the collector voltage for hFE figures at the extreme ends of the spread range, but this was done only for the purposes of demonstration. There would be no need for these extra calculations in normal work.

The concepts illustrated by Figs. 2 and 5 may be employed if it is desired that the transistor emitter in Fig. 1 or the transistor collector in Fig. 4 be at a voltage other than half supply voltage. R_x or R_y is given a value which will cause the required voltage to appear at its junction with R_1 , and the calculations are then carried back to R_1 . In Fig. 2

$$V_e \approx \frac{R_x}{R_1 + R_x} \cdot V_{cc}$$

and in Fig. 5

$$V_c \approx \frac{R_1}{R_y + R_1} \cdot V_{cc}$$

None of the calculations in this article takes account of base leakage current, which can upset operation if R_1 has a very high value. It is necessary to avoid high values in R_1 in any case, since these will in practice cause variances in performance between different transistors of the same type number when the latter have low but nevertheless varying base leakage currents. ■

BACK NUMBERS

For the benefit of new readers we would draw attention to our back number service.

We retain past issues for a period of two years and we can, occasionally, supply copies more than two years old. The cost is the cover price stated on the issue, plus 6p postage.

Before undertaking any constructional project described in a back issue, it must be borne in mind that components readily available at the time of publication may no longer be so.

We regret that we are unable to supply photo copies of articles where an issue is not available.

Libraries and members of local radio clubs can often be very helpful where an issue is not available for sale.

OSCAR — PROGRESS REPORT

by

Arthur C. Gee, G2UK



Checking OSCAR 6 before launch

SINCE BEING LAUNCHED LAST October, OSCAR 6 has made more than 2,000 orbits! A steady stream of amateur radio contacts in many countries have been made through it, the up-link being in the 2 metre band and the down-link being around 29.5MHz. In addition, a telemetry signal has been radiated from the Satellite in the 70cm. band, and also in the 10 metre band. A lot of experience has thus been acquired about the use of an amateur radio satellite for communication purposes, and a not insignificant amount of useful scientific data has been obtained.

Inevitably, various snags have come to light with the present OSCAR, which are being taken care of in the designs now going forward for the next OSCAR. The latest issue of the AMSAT Newsletter, which is issued quarterly by the Radio Amateur Satellite Corporation, gives a most interesting account of some of these designs. In January, for instance, the 70cm. beacon power dropped unexpectedly, to such an extent that only those receiving stations with the very best of 70cm. receiving equipment

were able to hear it — it is thought this may be due to a transistor failure. The internal temperature, and particularly that of the batteries, has become much higher than planned; it has gone up to 47°C (117°F), whereas the designed temperature was 15-20°C (60-70°F) — this may lead to a shortened battery life. Internally generated, random switching of some of the experimental control logic circuits has been taking place. This has been overcome by the primary control station in Canada automatically sending a programmed list of commands to the satellite every 2½ minutes during each pass, the instructions being on punched teletype tape. One of the solar panels appears not to be functioning properly. Due to the small dimensions of OSCAR 6, there was less space for solar panels than the designers would have liked, so that the nickel cadmium batteries are not getting all the recharging they should. As a result, use of the satellite's communication facilities has had to be restricted to 0000 hrs. GMT Thursday to 2400 hrs. GMT Mondays.

Much was heard at the beginning of OSCAR 6's flight about those stations which were using excessive power to communicate through it. Using an effective radiated power in excess of 100 watts depresses the gain of the translator and reduces the strength of other signals in the passband. Another problem encountered by many stations was that their 10 metre receiving capability was much poorer than they thought — this was certainly the case with the writer of this note! As Bill Tynan, W3KMY, points out in an article entitled "Operations", in the AMSAT Newsletter, "This may be one reason why some users run too much power. They keep turning the wick up, until they hear a good signal on the downlink." This issue of AMSAT NEWSLETTER, contains a useful descriptive article of a "Preamplifier

for 29.5MHz", which will help greatly in this direction.

On the 30th January 1973, the AMSAT Board of Directors, agreed on the plans for the next OSCAR. In the planning stage this will be known as AMSAT-OSCAR-B (A-O-B) and it will be given an OSCAR number designated once successfully in orbit.

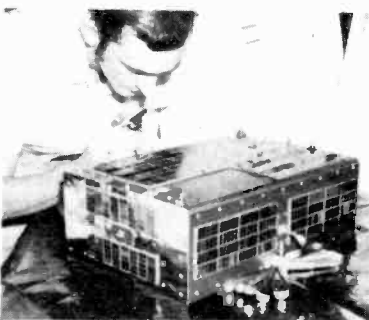

The satellite showing the metal tape antenna folded up in front

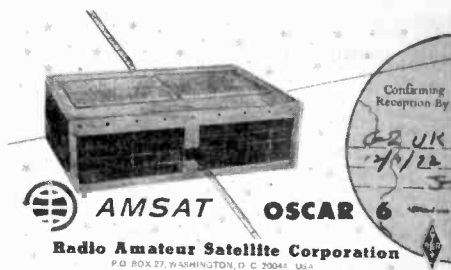

AMSAT OSCAR 6 QSL card

It will have three translators, viz a 432-146MHz unit; a 5 watt 146-29.45MHz unit and a 1 watt 146-29.45 MHz unit. There will be a beacon on 435.1MHz; a Codestore Unit and a Morse Code and RTTY telemetry unit. A second satellite will be constructed at the same time by the WIA Project Australis Group, which will contain the Australis 2 metre to 70cm. FM repeater and telemetry units.

Membership of AMSAT is open to individuals; this will enable them to receive the AMSAT Newsletter, quarterly, in which all the most up to date information on this latest aspect of amateur radio is to be found. For particulars of membership send to AMSAT, P.O. Box 27, Washington, D.C. 20044.

ASTABLE MULTIVIBRATORS

Part 1 by A. Foord

This is the first of two articles describing astable multivibrators, and in it the author discusses the cross-coupled and emitter coupled configurations. Next month's article will deal with frequency and duty cycle control, and with multivibrators incorporating the SN74121 integrated circuit.

THE ASTABLE MULTIVIBRATOR CIRCUIT IS A SQUARE OR rectangular waveform generator which may be free running, triggered, or synchronised to an input waveform. It is used to generate clock pulses which can be logic compatible. It is simple and inexpensive and may be used where frequency stability is not a critical requirement. A mark to space ratio of about 10 to 1 can be obtained without using complex circuits.

BASIC OPERATION

The basic operation for a cross-coupled transistor astable multivibrator is illustrated in Fig. 1. It may be considered as two transistor switches connected together with capacitors. When the supply is switched on, both transistors will tend to conduct because base current can flow through the base resistors. However one transistor (perhaps TR1) will turn on faster than the other, depending on the gains and switching speeds, so a negative pulse will be passed through C2 to the base of TR2, to turn it off. Transistor TR1 will then turn hard on and saturate, while the other transistor, TR2, is held off by a negative potential on its base. C2 will now, however, charge up exponentially through R2 towards Vcc. When the potential on the base of TR2 becomes slightly positive, then TR2 will conduct and its collector voltage will fall. This negative transition is passed through C1 to cut off TR1. The collector voltage of TR1 will rise and the positive transition will in turn make TR2 conduct. This regenerative action will rapidly switch TR2 on and TR1 off.

The base of TR1 is taken negative by approximately the supply voltage and it then rises exponentially

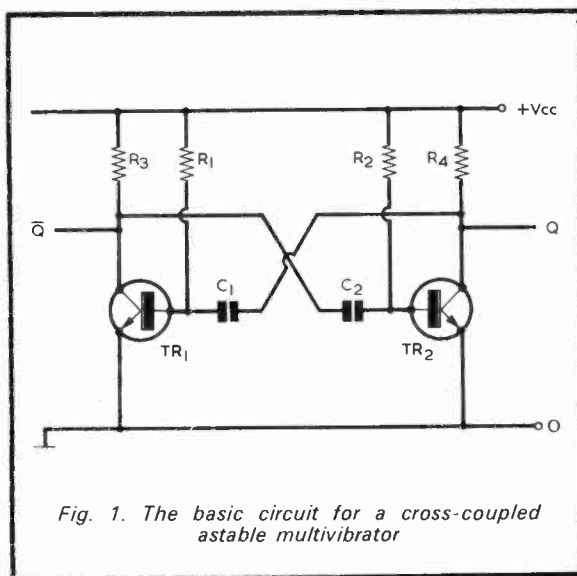

Fig. 1. The basic circuit for a cross-coupled astable multivibrator

towards the supply voltage, following the time constant curve for C1 and R1. When the base of TR1 becomes slightly positive this transistor will conduct, whereupon regenerative feedback occurs and the circuit changes state once more.

Two outputs, Q and not-Q (the term 'not' being indicated by the horizontal bar over the letter), are available at the collectors.

The off period (t) for each transistor depends on the base time constants.

With TR1:

$$t_1 = 0.69 \times C_1 R_1,$$

while, with TR2:

$$t_2 = 0.69 \times C_2 R_2.$$

The total time of one cycle (T) is given by

$$T = t_1 + t_2,$$

and frequency (f) is given by:

$$f = \frac{1}{T} \text{ Hz.}$$

The first two equations assume that the associated transistor comes on when its base has risen to zero potential. In practice a silicon transistor turns on when its base reaches about 0.6 volt, whereupon the off period is slightly longer than that given by the formula. This effect is more significant when a low supply voltage is used.

EMITTER-BASE REVERSE BREAKDOWN

In Fig. 1 the emitter-base junction of each transistor is reverse biased by an amount approximately equal to the supply voltage. With some transistors this voltage may exceed the base-emitter reverse breakdown figure. Such breakdown would not be harmful if the current were limited, but it would result in an unpredictable frequency of oscillation. Some germanium transistors, the 2N1308 for example, have a 25 volt reverse base-emitter rating and can be used with supplies of up to 12 volts or more. The silicon 2N706A has a rating of 5 volts only, but it can be used with a 5 volt supply rail where a logic compatible circuit is required.

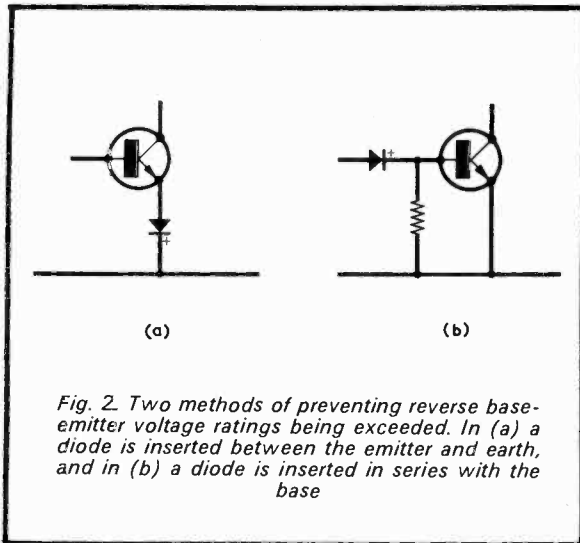

Fig. 2. Two methods of preventing reverse base-emitter voltage ratings being exceeded. In (a) a diode is inserted between the emitter and earth, and in (b) a diode is inserted in series with the base

There are two techniques, shown in Figs 2 (a) and (b), which may be used to prevent base-emitter breakdown in cases where it is essential to employ a transistor with a low reverse base-emitter rating. The circuit of Fig. 2 (a) has the advantages of protecting the transistor and preventing base circuit loading, together with the disadvantages that collector current is limited by the diode rating and that base and collector saturation voltages are increased. The circuit shown in Fig. 2 (b) allows high collector currents. An additional resistor has to be added to couple the base to the lower supply rail with germanium transistors.

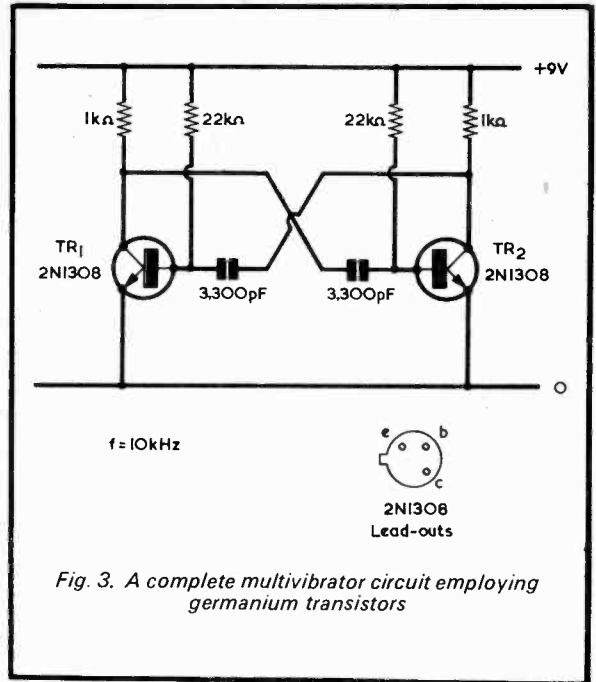

Fig. 3. A complete multivibrator circuit employing germanium transistors

TYPICAL CIRCUITS

Two typical circuits are given in Figs. 3 and 4, using germanium and silicon transistors respectively. Both circuits are designed for medium gain transistors and will work with almost any transistors provided their reverse base-emitter voltage ratings are equal to or greater than the supply rail voltage. In each case a one-to-one mark-space ratio has been chosen; this may be varied if required by altering the capacitor values. If the base resistor values are altered care should be taken to make sure that the values are low enough for the transistors to switch on properly.

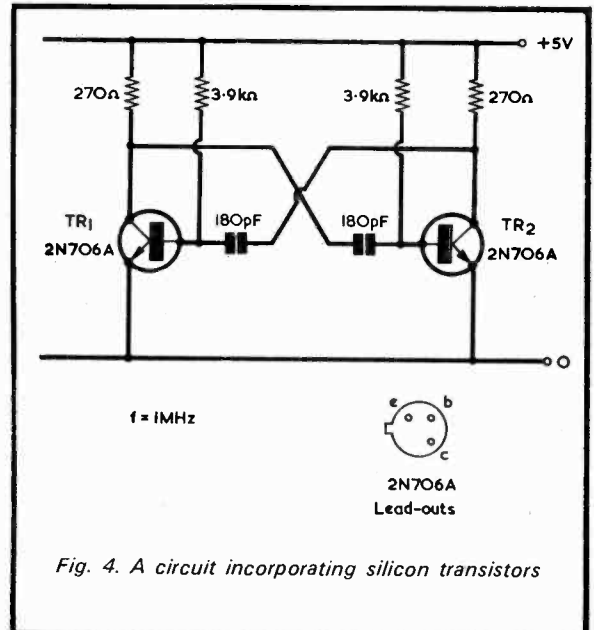

Fig. 4. A circuit incorporating silicon transistors

EMITTER COUPLED MULTIVIBRATOR

Another type of multivibrator is the emitter coupled version. When a multivibrator of this type is used as a clock pulse generator it has several advantages over the cross-coupled multivibrator illustrated in Figs. 1, 3 and 4. These include the possibility of faster operation with given transistors, a single timing capacitor, less dependence on power supply variations, and a completely free collector output. A frequency variation of 1% for a supply voltage change of $\pm 50\%$ is typical. Unfortunately the a.c. and d.c. operating conditions are not easily calculated, and so this article will simply give a typical circuit together with a practical example of component values.

The basic circuit of the emitter coupled multivibrator is given in Fig. 5 (a) and the appropriate waveforms appear in Fig. 5 (b). If we assume that TR1 is conducting

and TR2 is off, then the emitter current of TR1 is split into two parts. One current, I_1 , flows through R_3 , while a charging current, I_2 , reduces the voltage on the emitter of TR2. Eventually the base-emitter threshold voltage of TR2 is exceeded and TR2 conducts so that some of the current flowing in R_4 is diverted through TR2.

The emitter current of TR1 falls, and the collector voltage of TR1 and the base voltage of TR2 rise, and TR2 conducts more heavily. There is, in consequence, a regenerative condition which forces the circuit to the state where TR1 is off with TR2 on.

A similar sequence later brings the circuit back to its original state.

The circuit shown in Fig. 5 (a) has separate supplies for the collectors and emitters. If the ratio between the collector and emitter voltages can be kept constant, very good frequency stability can be obtained. This can be achieved by using only one supply and deriving the base reference from a potential divider.

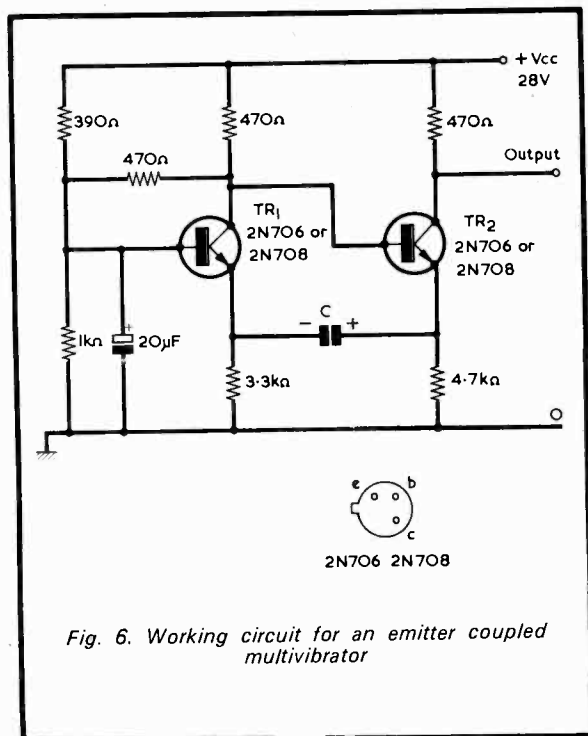
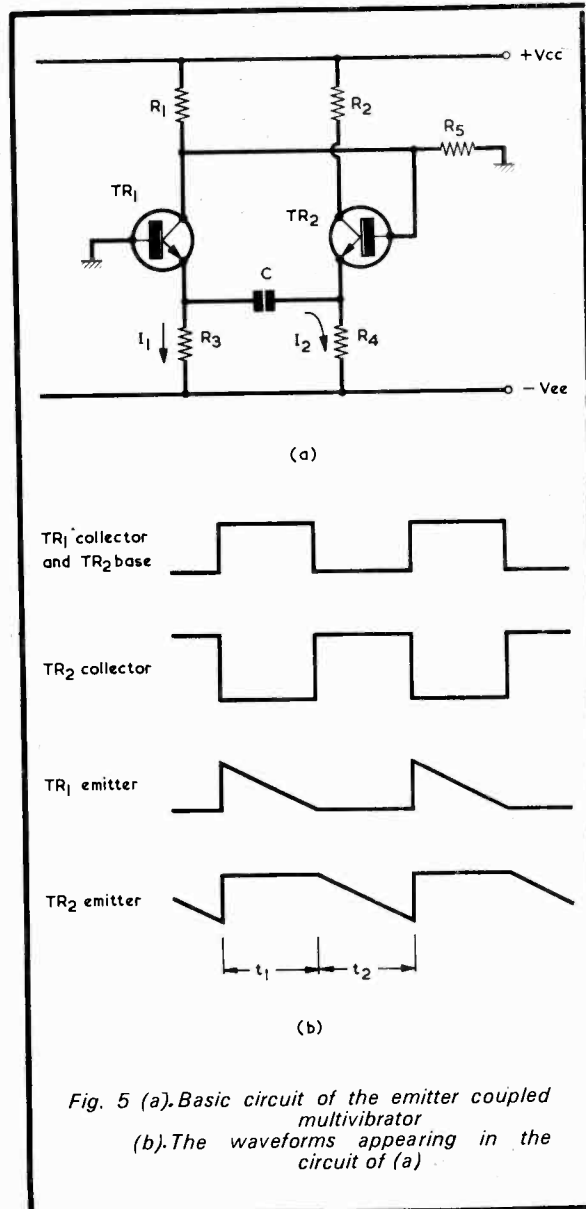

A practical circuit is shown in Fig. 6. Because of its complexity, no formula is given for frequency and this is best found by experiment. As a starting point it will be found that, with the resistor values shown, a value in C of $0.04\mu\text{F}$ will give a total period of $28\mu\text{s}$ (corresponding to a frequency of about 35kHz). Increasing C will increase the period, and vice versa. The mark-space ratio ('mark' corresponding to TR2 on) with the $0.04\mu\text{F}$ capacitor is approximately 12:16. Incidentally an electrolytic capacitor may be used for C if low frequencies are required because the polarity of the voltage across this capacitor does not reverse. The polarity is shown in Fig. 6.

The circuit of Fig. 6 can be used up to 1MHz without difficulty, and to 10MHz if higher frequency transistors are employed.

(To be concluded)

In your workshop



CHEERFULLY, DICK THREW OPEN THE door and bustled in. The warm early-morning June sunshine cut a bright swathe through the interior of the Workshop, causing dancing motes of dust to glister brightly.

As always, Smithy had already arrived. Dick glanced over at the Serviceman, and saw that he was gazing fondly at a piece of equipment on his bench. Dick closed the door, then wandered over to make a closer examination. The equipment on the Serviceman's bench consisted of a small metal case, from the rear of which protruded a flexible cable terminated in a mains plug. On the front panel of the case were mounted a toggle switch, a rotary switch, four small m.e.s. bulbholders, each with a bulb inserted, and three large terminals. Connected to the terminals were three short flexible leads fitted with miniature crocodile clips. A cardboard box containing assorted transistors lay in front of the case.

TRANSISTOR IDENTIFIER

"Hallo," remarked Dick. "What's all this, then?"

Smithy aroused himself from his preoccupation with the equipment and turned to face his assistant. He then looked at the Workshop clock.

"Dear me," he said mildly, "I thought you were taking the day off." "Oh, come on, Smithy," retorted Dick. "I'm only two minutes late this morning. What's that you've got on your bench?"

"Ah, this," said Smithy, forgetting Dick's perennial lateness in arriving to work. "Well now, this is my latest invention."

He gestured at the unit affectionately.

JUNE 1973

"It's a device," he pronounced proudly. "for identifying transistor lead-outs. It will also tell you whether a transistor is p.n.p. or n.p.n. I've been making it up as a sort of home-work over the last few evenings."

"Blimey," remarked Dick, impressed. "It certainly sounds useful. Sorting out transistor lead-outs these days is no end of a bind, particularly when there are so many types around which don't seem to be listed in the data books."

"That's very true," agreed Smithy. "Incidentally, before I start telling you about this instrument of mine, I should mention that there's a fairly simple dodge for finding the lead-outs of an unfamiliar transistor which merely involves the use of a testmeter. As you know, a transistor can be looked upon as consisting of two diodes connected back-to-back. With a p.n.p. transistor the two diodes have their cathodes in the centre, and with an n.p.n. transistor the two diodes have their anodes in the centre." (Figs. 1(a) and (b).)

It looked as though Smithy was firmly embarked on one of his technical dissertations. Unobtrusively, Dick pulled a stool towards him and settled himself comfortably.

"I suppose," he remarked, "that the testmeter used for this dodge is switched to an ohms range."

"That's right," confirmed Smithy. "Now, almost all standard testmeters have an internal circuit which, when the meter is switched to read resistance, causes the positive test lead to carry a negative voltage and the negative test lead to carry a positive voltage. These voltages are provided by the internal battery of the testmeter. In case of doubt, the polarity for any particular testmeter switched to ohms can always be checked for certain by connecting its lead-outs to another testmeter

This month Smithy the Serviceman digresses from his usual pursuits and demonstrates to his assistant Dick an intriguing and unique item of test equipment. This device is capable of identifying the three lead-outs of almost any bipolar transistor that is connected to it.

switched to read volts."

"Yes," commented Dick. "I've bumped into this reversal of test lead polarity on the ohms range of testmeters before now. It can be quite muddling if you don't take it into

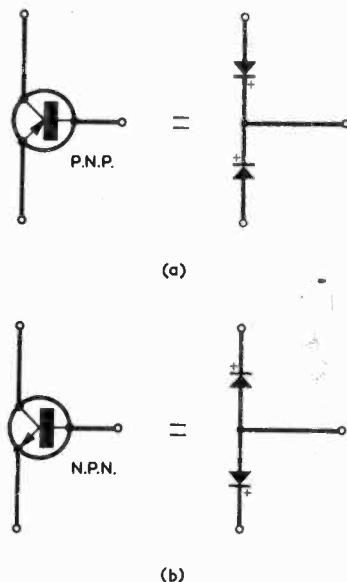

Fig. 1 (a). A p.n.p. transistor can be represented as two diodes connected back-to-back with cathodes in the centre
(b). An n.p.n. transistor may be represented as two diodes of opposite polarity

account when checking things like diodes."

"True enough," concurred Smythy. "Well, if you want to identify the lead-outs of a transistor you switch the testmeter to a fairly high ohms range and apply its test prods to the transistor lead-outs successively until you find a lead-out which shows low resistance to both of the other two lead-outs. That lead-out is then the base of the transistor. If you get this effect with the positive testmeter lead connected to the base then the transistor is a p.n.p. type. And if you get it with the negative testmeter lead connected to the base then you've got an n.p.n. transistor."

"That's all right so far," remarked Dick critically. "But, after you've carried out the rather fiddling business of applying the testmeter leads to the transistor lead-outs, you've still not been able to do anything more than identify the base. You still don't know which of the other two lead-outs is the emitter and which is the collector."

"That's where the main part of this dodge comes in," chuckled Smythy. "After you've found the base lead-out you make the assumption that one of the remaining lead-outs is the emitter and that the other is the collector, and you then connect the test prods to these two lead-outs with the voltage polarities they would receive if the transistor was acting as a common emitter amplifier. The testmeter will indicate a very high resistance and it may happen that its needle won't even be deflected. You next wet two finger tips on your tongue and apply them to the lead-outs of the base and what you assume is the collector. If the resistance indicated by the meter drops very markedly, then the lead-out you have assumed to be the collector is the collector. The fall in resistance indication is due to increased collector current resulting from transistor action. But it is possible for some fall in resistance reading to take place with the transistor connected wrong way round, because the meter could then read the resistance between your finger tips in series with the collector-base junction. So you reverse the testmeter connections and repeat the operation assuming that the alternative lead-out is the collector. The lead-out with which you get the greater drop in resistance indication is the collector." (Fig. 2).

"I see," said Dick. "I must try out that idea some time."

"I should," advised Smythy. "Do it on a few odd transistors first to get the feel of things. The idea works best with modern silicon transistors, and you may not get such helpful indications with some of the earlier germanium types. The scheme is quite useful if you're pushed and need to find the lead-outs of only one or two transistors, but it's a bit long-winded if you want to identify the lead-outs of a lot of transistors."

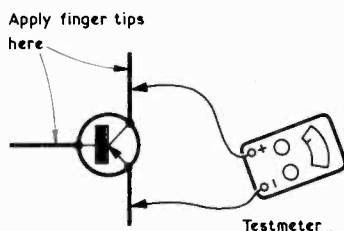

Fig. 2. An illustration of a method of identifying the collector lead-out of a transistor. The testmeter is switched to a high ohms range and the resistance reading it gives drops markedly if the finger tips are applied as shown

CIRCUIT MODES

"And I suppose," remarked Dick, carefully steering the conversation in the desired direction, "that's where this gadget of yours comes into the picture."

Smythy drew himself up.

"It's where," he returned reprovingly, "this instrument of mine comes into the picture, since it is intended to simplify the identification of transistor lead-outs. I must point out before going any further, though, that this instrument is a wee bit in the experimental class and that it might not work satisfactorily with a few transistors. However, it hasn't failed on any of the transistors I've tried out on it myself since I knocked it up, and these include germanium and silicon types both in low and in high power categories."

"How do you use it?"

"You connect the transistor to the three terminals on the front panel, then turn the rotary switch until you obtain a certain pattern of illumination in the four bulbs. The switch position then tells you which transistor lead-outs are emitter, base and collector, and the lights tell you whether the transistor is a p.n.p. or an n.p.n. type."

"How many positions does the rotary switch have? Three?"

"No. Six."

"Six? How do you have six positions when there are only three lead-outs to identify?"

"The switch has six positions," explained Smythy, "because the three transistor lead-outs can be connected to the three test terminals of the instrument in six different ways. I'll go through them with you next, and I'll show you then how the instrument responds to the six different methods of connection."

Smythy reached over the surface of his bench and pulled his note pad towards him. He took a pen from the top pocket of his overall jacket and scribbled out a circuit. (Fig. 3(a).)

"Now the basis of this piece of equipment," he went on, "is that three terminals, which I've called terminals

1, 2 and 3, are available for connection to the transistor whose lead-outs are to be identified. Let's refer to this as the 'test transistor'. Terminal 3 connects to the chassis of the equipment; terminal 1 connects to a supply rail, which may be either positive or negative of chassis, by way of a 20kΩ resistor; and terminal 2 connects to the same supply rail by way of a 1kΩ resistor. The instrument functions by sensing whether the voltages with respect to chassis on terminals 1 and 2 are high or low."

"High or low?" queried Dick. "Can't you have an instance when the voltage on a terminal may be at an intermediate level?"

"Not in the present case," replied Smythy. "As you'll soon see when I start explaining things in a bit more detail."

He indicated the circuit he had just sketched out.

"Now this is my first example of transistor connection," he continued. "It so happens that I have connected the test transistor such that its emitter goes to terminal 1, its collector to terminal 2 and its base to terminal 3. For the time being, we'll assume that we are checking a p.n.p. transistor."

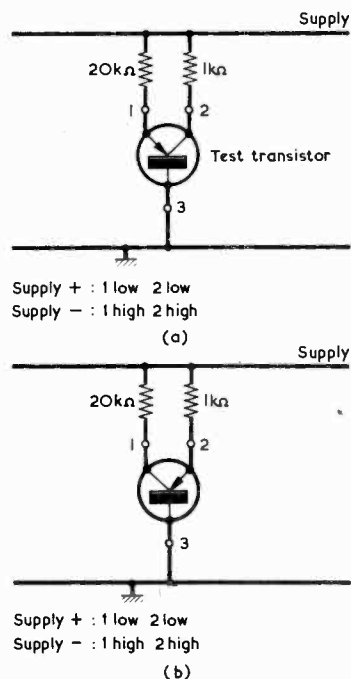

Fig. 3. Smythy's transistor identifying device has three terminals which connect to the test transistor. In (a) the emitter of the test transistor connects to terminal 1, the collector to terminal 2, and the base to terminal 3. The emitter and collector are changed over in (b)

Dick gazed at the diagram.

"Well," he said slowly, "we've already referred to a transistor as being the same as two diodes connected back-to-back. So far as I can see, it will work in the same way as two diodes here."

"Good," said Smithy approvingly, "you've got the idea right away. The test transistor will act like two diodes whose cathodes connect to chassis. When the supply rail is positive both diodes will conduct and the voltages on terminals 1 and 2 will be low. For a silicon transistor they will be about 0.6 volt and for a germanium transistor about 0.2 volt. Both these levels fall into the category of 'low'. And, when the supply rail is negative neither of the two diodes will conduct. The voltages on terminals 1 and 2 will then rise to that on the supply rail and they can be described as being 'high'."

"These low and high voltages," Dick pointed out, "are of different polarities. The low ones are positive with respect to chassis and the high ones are negative."

"That's correct," confirmed Smithy. "And the instrument does in fact take advantage of this point. Now, let's connect up the test transistor in a different manner."

Smithy drew out a further circuit. (Fig. 3(b).)

"What I've done this time," he went on, "is to connect the collector to terminal 1, the emitter to terminal 2 and the base to terminal 3."

"You'll get the same effect as you had before," remarked Dick. "You'll have the two diodes again, with cathodes connecting to terminal 3. The voltages on the terminals will both be low when the supply rail is positive, and they'll both be high when the supply rail is negative."

"Right," said Smithy briskly, scribbling out another circuit. (Fig. 4(a)). "In this instance I've connected the base to terminal 1, the collector to terminal 2 and the emitter to terminal 3. What happens now?"

Dick looked at the diagram thoughtfully.

"Why, blow me," he said suddenly, "it's just an ordinary common emitter amplifier circuit. Base current will flow between the base and emitter and this will turn the transistor hard on."

"So?"

"So, since the transistor is a p.n.p. type, both the base and the collector will be low when the supply rail is negative and high when the supply rail is positive."

"Fine," commented Smithy. "In other words, terminals 1 and 2 are both low when the supply rail is negative and are both high when the supply rail is positive. I should add that, due to the two different resistor values, this assumes that the test transistor will have a current gain of at least 20, which is almost certain to be the case in practice."

He busied himself once more with

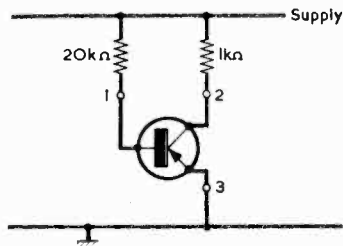

Supply + : 1 high 2 high
Supply - : 1 low 2 low

(a)

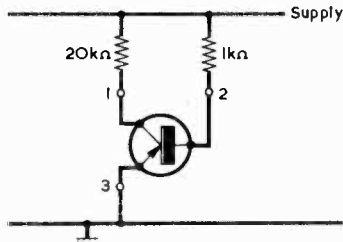

Supply + : 1 high 2 high
Supply - : 1 low 2 low

(b)

Fig. 4 (a). Here, the test transistor has its base connected to terminal 1, its collector to terminal 2 and its emitter to terminal 3. Voltage conditions at terminals 1 and 2 are shown

(b). The circuit given when the base and collector are transposed

his pen. (Fig. 4(b).)

"This time," he said, "I've put the collector to terminal 1 and the base to terminal 2. We once again have a common emitter amplifier circuit, with the transistor biased hard on. The result is that both terminals 1 and 2 are low when the supply rail is negative and are both high when the supply rail is positive."

REVERSE AMPLIFICATION

Smithy thought for a moment, then drew out another circuit. (Fig. 5(a).)

"This is where we come to a tricky bit," he remarked. "As you can see, I've taken the emitter of the test transistor to terminal 1, the base to terminal 2 and the collector to terminal 3. Now, as you'd expect, terminal 2 will go low when the supply rail is negative because the collector-base junction diode will then be conductive. What may surprise you, however, is that the emitter will go low, too."

Dick's jaw dropped.

"Come again?" he gasped. "How the heck can that happen? The emitter-base junction diode is the wrong way round for it to pass current when the supply rail is negative."

"What's happening here," chuckled Smithy, "is not diode action but transistor action. Since a junction transistor is a symmetrical device it can offer amplification in the reverse direction, with the emitter working as a collector and the collector working as an emitter. The transistor will, in most instances, be an extremely inefficient amplifier when working in this manner but it will still offer the effect, nevertheless. In this diagram the transistor is operating in the reverse direction as a common emitter amplifier, and the collector is acting as an emitter and the emitter is acting as a collector. Because of the values of the two resistors, the current flowing in the base is about 20 times the maximum current which can flow in the 20kΩ resistor. As a consequence, provided that the transistor can offer a wrong-way-round gain of at least one-twentieth, or 0.05 times, it will come hard on as a reversed amplifier, and both terminals 1 and 2 will be low when the supply rail is negative. They will also, incidentally, be high when the supply rail is positive."

"Gosh," said Dick. "This takes a bit of getting used to! I feel that emitters and collectors should know their proper place in the scheme of things."

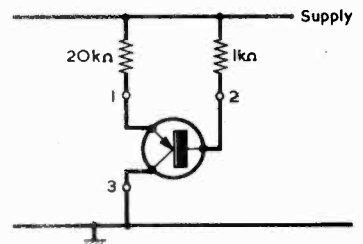

Supply + : 1 high 2 high
Supply - : 1 low 2 low

(a)

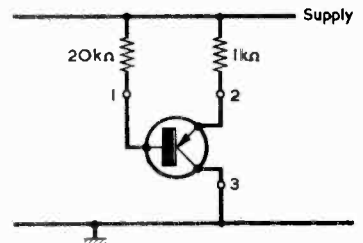

Supply + : 1 high 2 high
Supply - : 1 low 2 high

(b)

Fig. 5 (a). Due to reverse amplification, the transistor shown here causes both terminals 1 and 2 to become low in voltage when the supply rail is negative

(b). In this circuit the transistor functions as a conventional device

They shouldn't start swapping themselves over like this."

"It's us," returned Smithy, "who are forcing them to swap over. And don't forget that all we're asking of our wrong-way-round transistor is that it offers a gain of 0.05 times, which is considerably lower than unity. All the transistors I've checked in this last circuit have caused the negative voltages on terminals 1 and 2 to go low. Well now, I've shown you five different ways of connecting the transistor, so I'll press on to the sixth and last."

Smithy drew out the final method of connecting the transistor. (Fig. 5(b).)

"Here we are," he announced. "I've now connected the base to terminal 1, the emitter to terminal 2 and the collector to terminal 3."

"Will we get the same wrong-way-round amplification as we did previously?"

"It's very doubtful," said Smithy. "A current will flow through the base-collector diode of the transistor when the supply is negative, but this will be only one-twentieth of the current which can flow in the $1k\Omega$ resistor. So, unless the transistor has a wrong-way-round gain of at least 20, which is very unlikely, we'll have terminal 1 low and terminal 2 high when the supply rail is negative. Both terminals will be high when the supply rail is positive."

Smithy placed his pen on the bench and gazed expectantly at his assistant. The latter moved uncomfortably.

"Well?" questioned Smithy.

"Well what?"

"Don't you see what I've just demonstrated to you? I've shown you the six methods of connecting the test transistor and the resulting voltages on terminals 1 and 2."

"I know you have, Smithy," replied Dick warily, "and you've done it very well, too."

"Can't you see," persisted Smithy, "any difference between the voltages which are given in the sixth circuit and those which appeared in the five previous ones?"

Unhappily, Dick turned a look of utter incomprehension at Smithy's circuits. Suddenly, his face brightened.

"Ye gods," he exclaimed, "I've just spotted it! In the first five methods of connecting the transistor, terminals 1 and 2 always operated in pairs. They were either both high or both low. The sixth method of connecting the transistor is the only one which causes the two terminals to be opposite, with one being high and the other low."

"I'm glad you've fathomed that out," said Smithy pleased. "Because it explains the fundamental operation of my transistor lead-out identifying instrument. When this gives an indication that terminal 1 is low and terminal 2 is high, instead of the terminals being both low or both high, then terminal 1 must connect to the base of the test transistor, terminal 2 must connect to the emitter and terminal 3 must con-

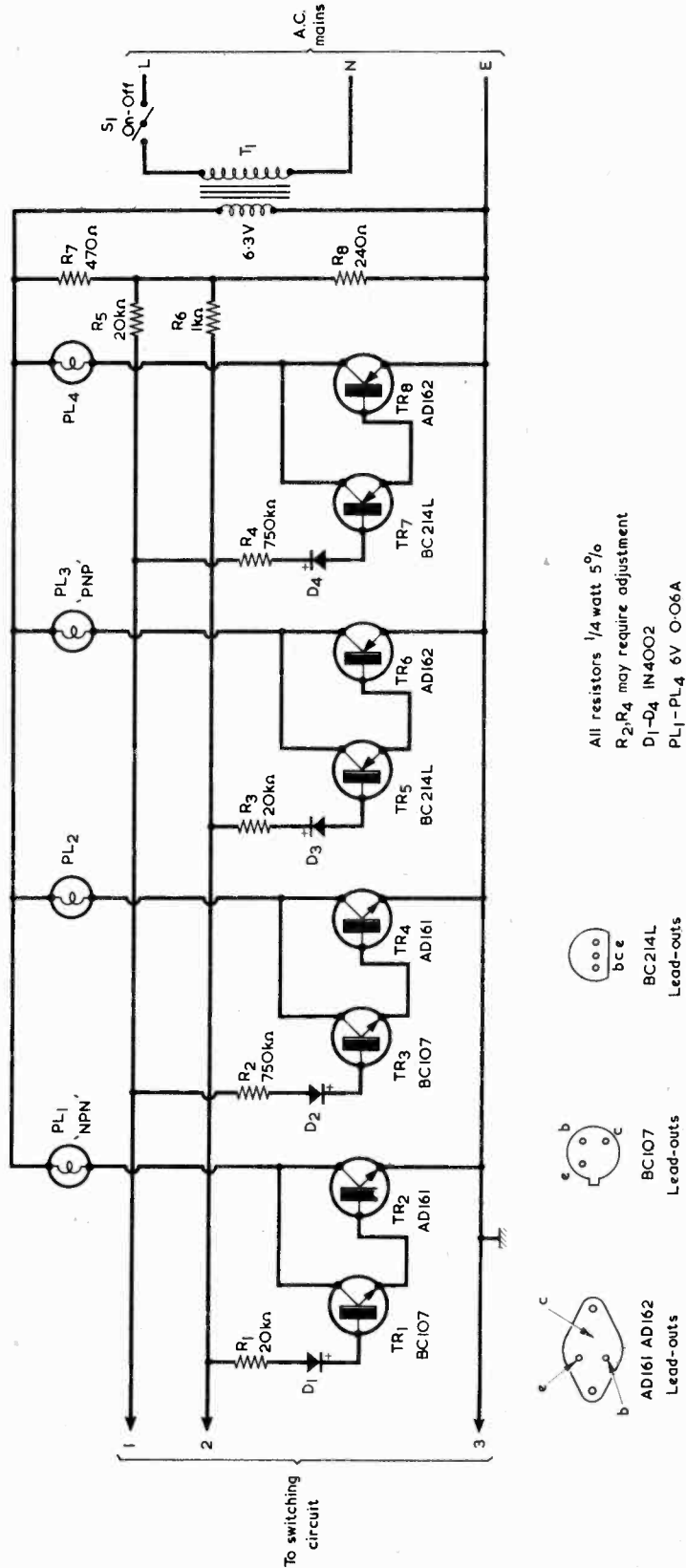

Fig. 6. The voltage sensing section of the transistor lead-out identifying equipment

nect to the collector."

"That," commented Dick appreciatively, "is really something, Smithy. You certainly had a brainwave when you dreamed up this little lot."

"I tend," remarked Smithy modestly "to have my odd moments of inspiration. However, let's pass on to a further point. In the six methods of connecting the test transistor which I've just shown you, we've assumed that this is a p.n.p. type. It could also, of course, be an n.p.n. type. An n.p.n. transistor will exhibit exactly the same results as does a p.n.p. transistor but for the opposite supply rail polarities. In the sixth method of transistor connection, therefore, terminal 1 for an n.p.n. transistor will be low and terminal 2 will be high when the supply rail is positive. This fact enables the instrument to tell you if the test transistor is p.n.p. or n.p.n. Anyway, let's get down to the circuit of the complete job."

COMPLETE CIRCUIT

Smithy picked up a piece of paper on which he had already drawn a circuit diagram and passed it over to Dick, who studied it closely. (Fig. 6.)

"This," explained Smithy, "is the sensing part of the circuit. The 20k Ω and 1k Ω resistors which I previously showed as connected to terminals 1 and 2 appear in this circuit as R5 and R6 respectively."

"What are the arrows at the left-hand end of the circuit which are numbered 1, 2 and 3?"

"Those arrows are the same as our previous terminals 1, 2 and 3," explained Smithy. "They couple to the 6-way rotary switch on the front panel of the unit. This selects different combinations of the three test transistor terminals, and when it selects a combination which causes the test transistor base to connect to terminal 1, the emitter to connect to terminal 2 and the collector to connect to terminal 3, the sensing circuit indicates that terminal 1 is low and terminal 2 is high. The position of the rotary switch is then noted, and the transistor lead-outs are read off from a chart."

"I notice," said Dick, "that the whole lot is powered by a 6.3 volt mains transformer."

"That's right," confirmed Smithy. "This can be any small heater transformer offering 6.3 volts at 0.5 amp or more. The supply rail voltage for the 20k Ω and the 1k Ω resistors is given at the junction of R7 and R8, and this is about 2.1 volts r.m.s. with respect to chassis, or approximately 3 volts peak. A voltage at this level won't exceed the reverse base-emitter voltage rating of most of the transistors that are liable to be connected to the instrument. You will note, of course, that we are now working with an alternating supply voltage, so that the circuit responds continually both to positive and negative supply rails."

"What about the transistors TR1 to TR8?"

"They're in circuit to sense whether the voltages on terminals 1 and 2 are low or high. If, for instance, you look at TR1 and TR2, you'll see that these are two n.p.n. transistors connected as a Darlington pair. They are capable of becoming conductive during the half-cycles when the top supply rail and terminals 1 and 2 go positive. TR1 couples to terminal 2 via R1 and D1 with the result that, if terminal 2 goes high on positive half-cycles, lamp PL1 becomes illuminated. Similarly, this lamp becomes extinguished if the voltage on terminal 2 is low during positive half-cycles. There is, also, no current in PL1 during the half-cycles when the upper supply rail and terminal 2 go negative."

"Is diode D1 included," asked Dick, "to ensure that there is no base current to TR1 during the negative half-cycles?"

"Not really," replied Smithy. "Transistors TR1 and TR2 wouldn't conduct on negative half-cycles in any case. The reason for incorporating D1 is to provide a voltage delay of about 0.6 volt so as to ensure good sensing discrimination between high and low levels on terminal 2. TR1 is a silicon transistor and TR2 is a germanium transistor and neither of these transistors will start to conduct until the positive voltage on terminal 2 rises above some 1.5 volts. This ensures reliable sensing of the high and low voltage conditions on terminal 2."

"I see" said Dick slowly. "The next two transistors, TR3 and TR4 are in pretty well the same sort of circuit as TR1 and TR2, except that they couple to terminal 1. I suppose that lamp PL2, in the collector circuit of TR4, lights up when the voltage on terminal 1 goes high."

"It does," confirmed Smithy. "And, also, these two transistors can only become conductive when the upper supply rail and terminal 1 is positive. TR5 and TR6 come next. These are p.n.p. types and they ensure that lamp PL3 lights up during negative half-cycles on the upper supply rail and terminal 2 when the voltage on terminal 2 is high. Transistors TR7 and TR8 do the same thing again for terminal 1."

"Do the lamps light up brightly?"

"They shine about half-brilliance," replied Smithy, "because when the associated transistors are conducting they only pass current during alternate half-cycles. The bulb brightness is, nevertheless, more than adequate for present requirements. I've used AD161's and AD162's for switching on the lamps despite the fact that these are somewhat larger than is warranted by the power which is dissipated in them. However, AD161's and AD162's fit very nicely into the circuit even if they are a little under-run here. Also, they're not very expensive and are quite easy to obtain. They don't need

Your Local Supplier

LONDON

THE MODERN BOOK CO.

Largest selection of English & American radio and technical books in the country.

19-21 PRAED STREET,
LONDON, W2 1NP

Tel: 01-723 4185/2926

ST. HELEN'S RADIO

Hi-Fi Equipment
Tape Recorders
Radio Receivers
Television

SPECIALISTS IN RADIO
& ELECTRONIC TEXTBOOKS

ST. HELENS GARDENS
LONDON, W.10

Tel: 01-969 3657

Electrolytic Capacitors by Mullard, Plessey, Erie, etc.

UF/V

1250/25, 2000/35, 2200/25,
4700/16, 8000/30, 10,000/15,
10,000/25, 1000+1000/40, 16+
16/500. All 35p each, post free.
2000/50, 2500/50, 5000/50,
10,000/50, 12,500/50, all at 50p
each, post free.
16+16/350, 32+16/350, 32+
32/350, 40+40/250, 50+50/300,
80+80/450, 100+100/385, all
at 25p each, post free.

ELEKON ENTERPRISES

224a, St. Paul's Road, Highbury Corner,
London N.1

HAMPSHIRE

BOURNEMOUTH

LARGEST HI-FI AND
RADIO COMPONENT
STORE IN THE SOUTH

FORRESTERS NATIONAL
RADIO SUPPLIES LTD.

70-72 Holdenhurst Road
Bournemouth

Telephone 25232

to be mounted on heat sinks.”

“There’s something else I’ve spotted,” said Dick. “The series resistors R1 and R3 are only 20kΩ, whilst R2 and R4 are 750kΩ. Why’s that?”

“I found in practice that I had to give R2 and R4 high values,” responded Smithy. “When the test transistor is connected in some modes it provides amplification between terminals 1 and 2 and causes cross-coupling between the different lamp circuits. With my prototype this effect completely cleared when I gave R2 and R4 the high values that I’ve shown in my circuit. Actually, R2 and R4 should have values that are just sufficiently low to bring on the associated transistors when terminal 1 is high. When this part of the circuit has been assembled it should be turned on with no external connections made to terminals 1 and 2. These terminals will then be high on all half-cycles and all four lamps should light up. If PL2 is markedly dimmer than PL1 and PL3, the resistance R2 should be reduced to a value which just allows PL2 to have about the same brightness as PL1 and PL3. The same applies to PL4, and the value of R4 should be carefully reduced if this lamp is significantly low in brilliance. The bulbs employed must be 6 volt 60mA types. Higher current bulbs might require too low a value in R2 and R4.”

SWITCHING CIRCUIT

“Well, all that seems very straightforward,” commented Dick. “What about the switching circuit which selects the different test terminal connections?”

Smithy ruffled through some papers and produced another circuit diagram which he had also prepared previously. (Fig. 7.)

“Here it is,” he remarked cheerfully, “and the rotary switch required is a 3-pole 6-way type. If you can’t get a 3-pole 6-way rotary switch already made up, then you can assemble it with R.S. Components ‘Maka-Switch’ parts. Two 2-pole 6-way wafers would meet the bill, with one of the poles being unused.”

“Blimey,” commented Dick, “that switching circuit looks very complicated.”

“It does rather,” confessed Smithy, “but that’s mainly because of the cross-connections involved. I’ve called the three test terminals X, Y and Z, and I’ve included a little table in the diagram showing how these are selected. On position 1 of the switch, terminal 1 goes to X, terminal 2 goes to Y and terminal 3 goes to Z. On position 2, terminal 1 goes to X, terminal 2 goes to Z and terminal 3 goes to Y. Some people might find it easier to wire up the switch working from the table rather than from the circuit.”

Smithy produced a further sheet of paper. (Fig. 8.)

“And there,” he announced, “is a

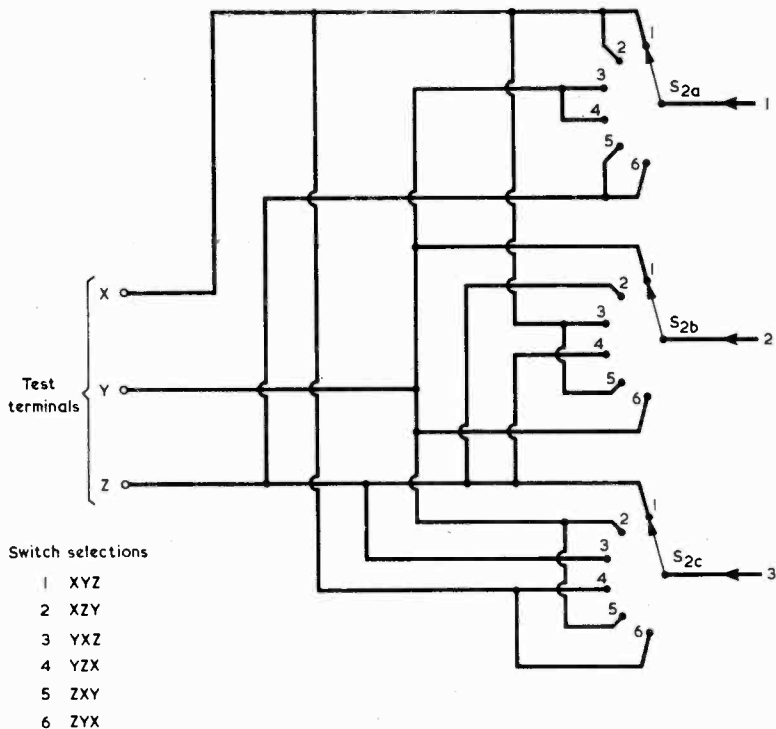

Fig. 7. The switching section of the equipment

table telling you what each switch position corresponds to. What you do is to connect the test transistor to terminals X, Y and Z, and then switch on the equipment by means of S1. You next rotate S2. A pair of bulbs, either PL1 and PL2 or PL3 and PL4, will always light up at every position of S1. But there will be one position where a third bulb will light up in addition to

one of the pairs, and that is the position which corresponds to the base of the test transistor going to terminal 1, the emitter to terminal 2 and the collector to terminal 3. If this third light is PL1 then the test transistor is an n.p.n. type because this will allow terminal 2 to be high on positive half-cycles. If the third lamp is PL3, then the test transistor is p.n.p.”

Switch position	Terminals		
	X	Y	Z
1	B	E	C
2	B	C	E
3	E	B	C
4	C	B	E
5	E	C	B
6	C	E	B

Fig. 8. This table shows transistor lead-outs connected to the test terminals for different settings of S2

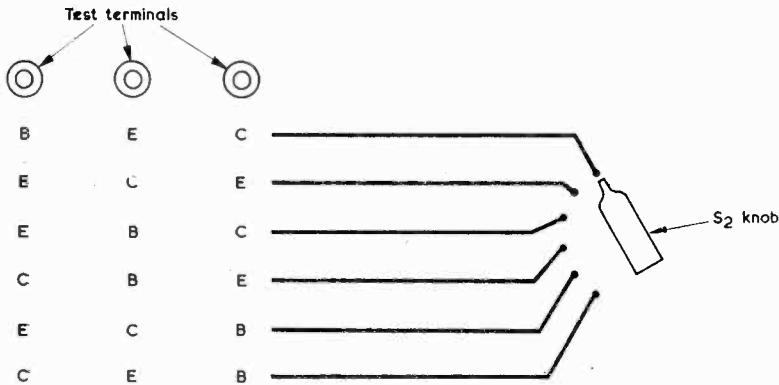

Fig. 9. If the front panel of the equipment is marked up in the manner shown here, the reference letters X, Y and Z, and the table of Fig. 8 can be dispensed with

"That's really crafty," remarked Dick. "I suppose you read off the transistor lead-outs from the table."

"You do," agreed Smithy. "If the 3-light display is given when S2 is in position 4, then terminal X connects to the collector of the test transistor, terminal Y to the base and terminal Z to the emitter. Actually, you could dispense with this XYZ business by positioning the table immediately below the three test terminals at the front panel with lines going to the knob of the rotary switch. Like this."

Smithy drew out the scheme he had suggested. (Fig. 9.)

"Why," remarked Dick, "haven't you used that idea on your own unit?"

"Because," confessed Smithy ruefully, "I've only just thought of it! I'll have to make the fitting of this direct-reading table to the front panel my very next job on this unit."

PACKING UP

Once again, Smithy turned an affectionate glance towards his creation.

"Are there," asked Dick, "any limitations to the usefulness of this unit?"

"There are a few," said Smithy. "As I mentioned a little earlier, the main thing is that it can't give correct readings if the transistor under test has a wrong-way-round gain of the order of 20 or more. A few of the older germanium transistors had fairly high reverse gains and these could possibly approach the 20 figure, although I haven't encountered any myself. There are, also, a few types knocking around

which are described as 'symmetrical transistors' and which have been purposely designed to have quite high wrong-way-round gains. The only ones in this category I can think of at the moment are the OC139, OC140 and OC141, which were produced for special computer applications. These three transistors have wrong-way-round gains of at least 21, and could not be checked on my unit. So far as construction of the instrument is concerned there are no particularly critical points except that it is desirable to house the parts in a metal case which is common to chassis. There can be a fair amount of gain in some parts of the circuit and a metal case will assist in providing stability of operation."

With these words, Smithy plugged his equipment into one of the mains sockets at the rear of his bench, picked up a transistor from the cardboard box in front of him and connected its three leads to the test terminals. He switched on the unit, whereupon two of the bulbs on the front panel lit up. Smithy turned the rotary switch until three bulbs became illuminated. The Serviceman indicated to Dick the line on his table which showed the corresponding transistor lead-out connections and then pointed to the third illuminated bulb, which revealed that the transistor was an n.p.n. type.

"Here," said Dick eagerly, as he picked up another transistor, "let me have a go."

Dick checked about a dozen transistors, then relinquished the unit to Smithy so that the Serviceman could check some more.

There wasn't much work done that morning.

Your Local Supplier

LANCASHIRE

AERIAL BOOSTERS

We make three types, L11 - VHF Radio, L12 - VHF 405 TV, L45 - UHF 625 TV. Price £2.95

TELEVISION VALVES

All types of TV Valves in stock, any five for 45p

TRANSISTOR - DIODES

BC113, BC115, BC117, BC135, BC171, BF173, BA102, BA129. Brand new, Price 1/10p any 100 - £7.

ERIE CERAMICS

4.7PF, 5PF, 6.8PF, 10PF, 12PF, 18PF, 18.5PF, 550PF, 820PF, 1000PF, 1200PF, 1500PF, 1800PF, 2700PF, 3300PF, 8200PF.

Many other values in stock.

Price 1/3p, 10/20p, 25/35p.

S.A.E. for Leaflets, P. & P. 10p.

Velco Electronics (R),
Ramsbottom, Bury, Lancs.

SOMERSET

RESISTORS

UNREPEATABLE CLEARANCE LINE
TOP QUALITY CARBON FILM

$\frac{1}{10}$ - $\frac{1}{4}$ - $\frac{1}{2}$ - 1 - 2 watt 5% Tol. Std. Limited No. 2% Hi-Stab. $\frac{1}{8}$ & $\frac{1}{4}$ W. only. Wide Choice Values, E24 Series But NOT COMPLETE RANGES Values, your choice in 5s, nearest Subs. given if not available.

5% Std. 55p/100, £5/1,000 No V.A.T. Hi-Stabs. 75p/100, £6/1,000 Post Free C.W.O.

Special Offer 1,000 Assorted £3. Min. 100 different types given.

WRAP RESISTORS,

9 Ellen Ct. se,
North Pe. erton
Som.

Tel:
N. Petherton
662501

SURREY

WITWORTH TRANSFORMERS

TV Line out-put transformers

Manufacturers of the largest range in the country. All makes supplied.

Free catalogue.

Modern

BAIRD, BUSH, GEC, PHILIPS

Replacement types ex-stock.

For "By-return" service, contact London 01-948 3702

Tidman Mail Order Ltd., Dept. R.C.

236 Sandycroft Road,

Richmond, Surrey TW9 2EQ

Valves, Tubes, Condensers, Resistors, Rectifiers and Frame out-put Transformers, Mains Transformers also stocked. Callers welcome.

SUSSEX

E. JEFFRIES

For your new television set
tape recorder, transistor radio
and hi-fi equipment

PHILIPS, ULTRA, INVICTA
DANSETTE, MASTERADIO, PERDIO,
MARCONI, PHILCO FIDELITY

6A Albert Parade
Victoria Drive,
EASTBOURNE SUSSEX

Radio Topics

By Recorder

IN A RECENT 'LETTER FROM AMERICA', on B.B.C. sound radio, Alistair Cooke recounted the sad tale of the American service engineer who maintains his TV receivers. It appears that this service engineer has hardly any social life at all. If he and his wife are invited to somebody's house for a party, the chances are that before the evening is out he will be summoned by his host away from the other guests to a room in which lurks a television receiver on the blink. He will then be asked for his advice on the best way of getting the set back to normal operation, with the veiled suggestion that he might as well have a stab at repairing it there and then.

That service engineer has now provided himself with a pocket tool kit which he takes with him whenever he is invited out.

SOCIAL PITFALLS

Most of us on this side of the Atlantic have experienced the same sort of thing. If people find out that one is connected with radio or television engineering then the hints start dropping like leaves in Autumn. Only the other evening, for instance, I was misguided enough to hold forth in my local about colour television, explaining that our present PAL system is an off-shoot from the original N.T.S.C. system proposed by R.C.A. in 1953. I should have known better. Within the next few days I was approached by no less than four people who, respectively, (a) had a TV set which took 15 minutes after switching on to settle down to a steady picture, (b) was contemplating buying a new TV and wanted to know what make I recommended, (c) had been presented with

an ancient and defunct TV set by his mother and (d) could only get a single ITV signal on u.h.f.

I just managed to sail through these advances, explaining to (a) that delayed warm-up was not uncommon in valve television receivers that had seen some years of service, advising (b) that it was impossible to recommend a particular make of set because all TVs are mass-produced and he might quite easily buy the last set to be assembled before Christmas break at the factory, informing (c) that I could not obtain spare parts for TV sets produced before 1955, and telling (d) that he might, with advantage, point his roof-top aerial in a different direction but that I couldn't help here because I can't stand heights.

I must confess it was a close thing, though, and that I nearly had to change my pub.

Competition in the States must be tougher than it is over here, and that American service engineer with his pocket tool kit must have been forced, to retain his customers, to accede to their occasional blandishments for a TV repair without payment whenever he was invited, pseudo-socially, to their houses. In this country we can afford to be harder and to put off people who try to scrounge TV service without forking out money for it. Oddly enough, it seems to be only electronics types who have to put up with this social harassment. If one meets a builder one hardly asks him for advice on re-pointing the chimney stack in anticipation of his arrival next evening complete with ladders; nor, if one encounters a doctor, does one make enquiries about the odd vasectomy and expect a quick job to be done on his next day off. It's just radio and TV people who suffer.

I suppose this is the old story of the luxury which, after a few decades, becomes a necessity. The automobile was originally a plaything for those who could afford it, but it nowadays forms an essential part of most peoples' livelihood. The telephone now plays a continual role in modern life-and-death dramas. Similarly, radio is an essential item for the dissemination of news. Or rather, was, since it has now been largely supplanted in this function by television with its occasional, but almost inevitable, unreliability.

So far as the future social eddy is concerned, I intend to confine any comments on my professional pursuits to hagiography; so if anyone wants an odd job done on the Dead Sea Scrolls I can refer them to the British Museum. And for the more pressing type of character who wants a job done on the cheap I might also declare a passing interest in taxidermy.

TELEVISION INTEGRATED CIRCUITS

A press release just received from SGS-ATES (and which quotes the address of this group as Via C. Olivetta 1, 20041 Agrate Br., Milan, Italy) gives details of the two integrated circuits shown in the accompanying photographs. Both of these are intended for television receiver applications and they manage to pack a great deal of circuitry into a very small space.

The first of the i.c.'s is the TCA 511, which is described as a 'TV horizontal and vertical processor'. In addition to a built-in voltage regulator this has a high stability horizontal oscillator, a horizontal a.p.c. circuit with high noise immunity and a large pull-in

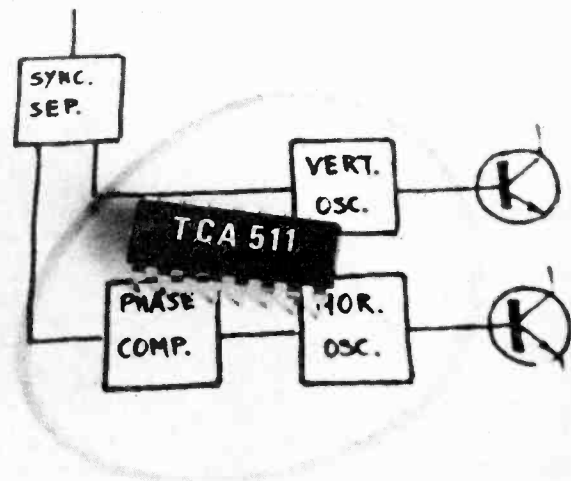

The SGS-ATES integrated circuit type TCA 511, designed for use in television receivers. This incorporates a horizontal oscillator, a horizontal a.p.c. circuit with wide pull-in range, and a vertical oscillator and sawtooth generator

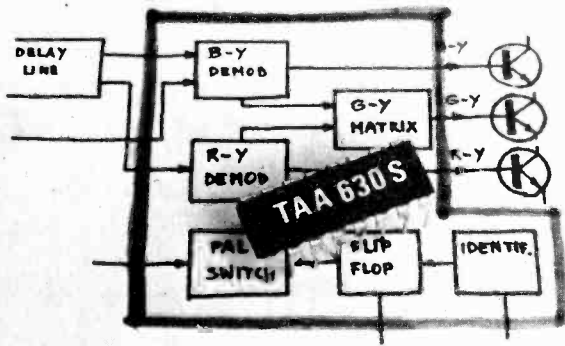

Another SGS-ATES i.c., the TAA 630S is intended for PAL television receivers. It provides synchronous demodulation, a matrix to produce the green colour-difference signal, a flip-flop, and a PAL switch and colour killer

range, a high stability vertical oscillator and a vertical sawtooth generator. The device is housed in a 16 lead dual in-line plastic package, and it can work with any stabilized supply voltage having a value between 9 and 15 volts.

The second i.c. is the TAA 630S, and this is also in a 16 lead dual in-line plastic package. It is intended for PAL colour television receivers and it incorporates the following functions: active synchronous demodulators for F(B-Y) and $\pm F(R-Y)$ signals, a matrix for producing the G-Y signal, a flip-flop, and a PAL switch and colour killer. Emitter follower outputs in B-Y, G-Y and R-Y are directly available, and there are no fewer than 48 transistors and 59 resistors in the chip.

HOCUS POCUS

In last month's issue I included a little numerical puzzle which appeared like this:

HOCUS
POCUS
PRESTO

Each letter in this addition sum stands for a different number and the problem is to work out what these numbers are.

Here's the solution:

92836
12836
105672

MENTAL OHM'S LAW

Every now and again most of us have to sit down and carry out an Ohm's Law calculation. We usually start from the basic Ohm's Law equation which states that resistance in ohms is equal to voltage in volts divided by current in amps. In most instances, however, we have to work in milliamps, with the result that the figure 1,000 enters the calculations and

we find ourselves burdened with a large number of noughts either before or after the decimal place. It's very easy to lose a nought, and the results of our computation may be that we get an answer that is either 10 times too small or 10 times too large.

There is a simple alternative approach to Ohm's Law calculations which enables them to be worked out mentally without introducing any serious errors at all. We first of all have to remember four obvious facts which are implicit in the Ohm's Law equation. The first of these is that if the voltage across a resistance increases so also does the current in the resistance. Similarly, if the current through a resistance increases so also does the voltage dropped across it. Thirdly, if the voltage remains constant and the resistance increases, then the current flowing in the resistance reduces. Finally, if the current remains constant and the resistance increases, the voltage across the resistance also increases.

We can now introduce some figures. If we apply a voltage of 1 volt to a resistance of 1 ohm, then 1 amp of current will flow. Should we increase the voltage to 2 volts then 2 amps will flow. If we keep the voltage at 1 volt and increase the resistance to 2 ohms then the voltage will drop to half an amp.

But in electronics we are more interested in currents of the magnitude of milliamps and microamps. So far as milliamps are concerned our starting point is that when a voltage of 1 volt is applied to a resistance of 1 kilohm ($k\Omega$), a current of 1 milliamp (mA) will flow. This must be so, because 1 kilohm is a thousand times greater than 1 ohm and so the current must be a thousandth part of an amp, which is a milliamp. If we apply 10 volts to a 10 kilohm resistor, once again 1 milliamp will flow. Should we have a transistor emitter resistor of 330 ohms and the voltage across that resistor is 1 volt, then the emitter current is approximately 3 milliamps.

Your Local Supplier

YORKSHIRE

PASSINGHAM'S ELECTRONICS
for Government Surplus
Radio & T.V. Components
Electronic Components
also postal service

PASSINGHAM'S ELECTRONICS
5 Dale Street
Bradford 1
Yorkshire

EIRE

PEATS for PARTS

ELECTRONIC COMPONENTS RADIO & TELEVISION

For the convenience of Irish enthusiasts we supply

The Radio Constructor
Data Books and
Panel-Signs Transfers

Also a postal service

Wm. B. PEAT & Co. Ltd.
28 PARNELL STREET
DUBLIN 1

BUILD THE TREASURE TRACER



METAL LOCATOR MKIII

- Incorporates varicap tuning for extra stability
- Weighs only 22oz and has perfect balance
- Loudspeaker or ear-phone operation (both included)
- Handle knocks down to only 17in. for transport
- Ministry approved design
- Excellent sensitivity and stability
- Kit can be built using only soldering iron, screwdriver, pliers and wire snips
- Drilled, tinned, fibre-glass p.c. board with component siting printed on
- Fitted with Faraday Screen.

SEND S.A.E. FOR LEAFLET

Complete kit with pre-built search coil	Plus 35p Post inc. V.A.T.	Built, tested and Guaranteed.	Plus 35p Post inc. V.A.T.
£9.80		£13.75	

MINIKITS ELECTRONICS,
35f Langley Drive, Wanstead,
LONDON E11 2LN (Mail order only)

We know that 1 volt across 1 kilohm corresponds to 1 milliamp, and we then say that 330 ohms is approximately a third of 1 kilohm and so the current must be approximately three times greater. Had the voltage across the 330 ohm resistor been 2 volts, we could have proceeded in two stages in the following manner: 1 volt across 1 kilohm gives 1 milliamp; 1 volt across 330 ohms gives 3 milliamps; therefore 2 volts across 330 ohms gives 6 milliamps. Thus, the emitter current is 6 milliamps. In the old days of valves, we frequently had anode load resistors of the order of 220 kilohms. If we found that the voltage across a 220 kilohm anode load resistor was 100 volts we could say: 1 volt across 1 kilohm gives 1 milliamp; 100 volts across 100 kilohms also gives 1 milliamp; 100 volts across 220 kilohms gives slightly less than half a milliamp. So the anode current in the 220 kilohm resistor is a little less than 0.5 milliamp.

It is surprising how quickly, after a little practice, one can fall into this volt-kilohm-milliamp routine, and it has the advantage of providing a thinking pattern which enables the currents in a circuit to be visualised nearly as readily as the voltages. I mentioned microamps a little earlier and here the procedure consists of starting off with the fact that a voltage of 1 volt across a resistance of 1 megohm ($M\Omega$) causes the flow of 1 microamp (μA) of current. 1 volt across 100 kilohms (which is one-tenth of a megohm) then corresponds to 10 microamps, and so on.

LOW COST LINEARS

Motorola Semiconductors Limited, of York House, Empire Way, Wembley, Middlesex, announce a new integrated circuit which, provided sufficient quantities are purchased, results in the availability of operational amplifiers at less than 10p each.

The new Motorola i.c. is the type MC3401P, and this contains four separate op-amps in a single plastic dual in-line housing. In quantities of more than 100 the MC3401P costs 37.3p, putting the price of individual operational amplifiers at less than 10p.

The MC3401P has a unity-gain bandwidth of 5MHz and an open-loop voltage gain of 1,000 minimum. Internally compensated, the device will operate from a single power supply of between 5 and 18 volts over the temperature range of zero to 75°C. Four amplifiers in one package typically draw 8mA from the power supply, and the input impedance of each op-amp is typically $1M\Omega$. Undistorted output voltage swing can be as high as 13.5 volts, and the isolation between amplifiers is typically 65dB at 1kHz.

Quite a change from the early days of semiconductors, when the list price of a.f. p.n.p. junction transistors was more than £1 each!

722

LOUDSPEAKER BARGAINS



Fane pop 100 watt 18" 8/15 ohm	£21.45
Fane pop 60 watt 15" 8/15 ohm	£12.26
Fane pop 50 watt 12" 8/15 ohm	£10.17
Fane pop 25/2 25 watt 8/15 ohm	£5.94
Fane pop 15 12" 15 watt 8/12 ohm	£4.40
Fane 122/10 a or 122/12	£9.90
Fane Crescendo 15" 8 or 15 ohm	£27.50
Fane Crescendo 12" 8 or 15 ohm	£24.20
Fane 8" d/cone 808T 8 or 15 ohm	£2.64
Fane 8" d/cone roll surr. 807T 8 or 15 ohm	£3.16
Baker Group 25 3 8 or 15 ohm	£6.00
Baker Group 35 3 8 or 15 ohm	£7.50
Baker De Luxe 12" d/cone	£9.62
Baker Major	£7.50
EMI 13 x 8 3, 8 or 15 ohm	£2.25
EMI 13 x 8 type 150 d/cone 3, 8 or 15 ohm	£2.58
EMI 13 x 8 type 450 1/2w 3, 8 or 15 ohm	£3.85
EMI 13 x 8 type 350 8 ohm	£8.25
EMI 6 1/2 93850 4 or 8 ohm	£2.80
Elac 9 x 5 RM 109 15 ohm	£2.53
Elac 9 x 5 59 RM 114 8 ohm	£2.53
Elac 6 1/2 d/cone 6 RM 220 8 ohm	£2.59
Elac 6 1/2 d/cone roll surr. 6 RM 171 8 ohm	£2.59
Elac 4" tweeter TW4 8 or 15 ohm	£1.21
Celestion PSB for UniJex	£2.16
Celestion MF 1000 25 watt horn 8 or 15 ohm	£10.45
Elac 5" 3 ohm	£1.75
Elac 7" x 4" 3 or 8 ohm	£1.52
Elac 6" x 5" 3, 8 or 15 ohm	£1.93
Wharfedale Bronze 8 RS/DD	£3.11
Wharfedale Super 8 RS/DD	£5.50
Wharfedale Super 10 RS/DD	£9.80
Goodmans 8P 8 or 15 ohm	£13.80
Goodmans 10P 8 or 15 ohm	£4.49
Goodmans 12P 8 or 15 ohm	£11.55
Goodmans 15P 8 or 15 ohm	£17.05
Goodmans 18P 8 or 15 ohm	£29.70
Goodmans Twinaxiom 8	£6.79
Goodmans Twinaxiom 10	£7.61
Goodmans Axent 100	£6.60
Eagle CT 33 dome tweeter 8 ohm	£4.95
Eagle HT 15 tweeter 8 ohm	£3.46
Eagle CT 5 tweeter 8 ohm	£1.21
Eagle MHT 10 tweeter	£3.30
Eagle CT 10 tweeter	£1.92
Eagle X overs CN 23, 28 216	£1.10
Kef T27	£4.67
Kef T15	£5.50
Kef B 110	£6.16
Kef B 200	£7.42
Kef B 139	£10.72
Kelkit 2	£24.75
Richard Allan 12" d/cone 3 or 15 ohm	£2.20
Richard Allan 8" 3, 8 or 15 ohm	£2.27
10" x 6" 3, 8 or 15 ohm	£1.92
8" x 5" 3 or 8 ohm	£1.38
7" x 4" 3 or 8 ohm	£1.38
3" 8 ohm or 80 ohm	£0.65
2 1/2" 84 ohm	£0.65
Speaker matching transformer 3/8/15 ohm	£1.10
Adastra Hiten 10" 10 watt 8 or 15 ohm	£2.80
Adastra Top 20 12" 25 watt 8 or 15 ohm	£6.32

STEPHEN SPEAKER KITS AND CABINETS

send for illustrated brochure and list of recommended speakers.

CAR STEREO SPEAKERS - ask for leaflet

PA/Disco amplifiers (carr. and ins. (£1.00))	
Baker 100 watt	£46.00
Linear 30/40	£25.00
Linear 40/60	£30.00
Linear 80/100	£50.00

FREE with speaker orders over £7 "HiFi Loudspeaker Enclosures" book

All units guaranteed new and perfect.
Prompt despatch.
Carriage and insurance 25p per speaker.
(Tweeters and Crossovers 15p each).

WILMSLOW AUDIO

DEPT RC

SWAN WORKS, BANK SQUARE,
WILMSLOW, CHESHIRE. SK91HF

AUDIO AMPLIFIERS



16 Transistor & Valve Designs for the Home Constructor

Amplifiers for
Tuner Units, Record Players,
Tape Recorders,
Public Address, etc., etc.

Includes contributions by such well-known authors as

A. S. Carpenter, A. Kinloch,
E. Govier, G. A. French,
F. G. Rayer, P. F. Bretherick,
K. Jones, D. Aldous,
R. Murray-Shelley, C. Swires,
G. A. Stevens and V. E. Holley.

Edited by J. R. Davies

124 pages

PRICE 53p

Postage 6p

To: DATA PUBLICATIONS Ltd.,
57 Maida Vale London W9

Please supply copy(ies)
of "Audio Amplifiers", Data
Book No. 18. I enclose cheque/
crossed postal order for.....

Name.....

Address.....

.....RC
BLOCK LETTERS PLEASE

SMALL ADVERTISEMENTS

Rate: 4p (9d) per word. Minimum charge 60p (12/-).
Box No. 10p (2/-) extra.

Advertisements must be prepaid and all copy must be received by the 4th of the month for insertion in the following month's issue. The Publishers cannot be held liable in any way for printing errors or omissions, nor can they accept responsibility for the *bona fides* of advertisers. (Replies to Box Numbers should be addressed to: Box No. —, Radio and Electronics Constructor, 57 Maida Vale, London, W9 1SN)

SERVICE SHEETS for Televisions, Radios, Transistors, Tape Recorders, Record Players, etc., from 5p. with free Fault Finding Guide. Catalogue 15p. Please send S.A.E. with all orders/enquiries. Hamilton Radio, 47 Bohemia Road, St. Leonards-on-Sea, Sussex. Telephone Hastings 29066.

MINT, BRANDED BC169C super-gain low noise npn, 10p. AD161/AD162 complementary pairs, 60p. Mail order only, U.K. post 5p. AMATRONIX LTD., 396 Selsdon Road, South Croydon, Surrey CR2 0DE.

BUILD IT in a DEWBOX robust quality plastic cabinet 2 in. x 2 1/2 in. x any length. S.A.E. for details. D.E.W. Ltd., 254 Ringwood Road, Ferndown, Dorset. Write now - right now.

FOR SALE: 100 BZY88, unmarked, untested zeners 50p. 1N4007, 10p. 10 for 60p. J. Fulton, Derrynaseer, Dromore, Co. Tyrone, Ireland.

CATALOGUE NO. 18, containing credit vouchers value 50p, now available. Manufacturers new and surplus electronic and mechanical components, price 23p post free. Arthur Sallis Radio Control Ltd., 28 Gardner Street, Brighton, Sussex.

WANTED: Early books on wireless, pre-1925. Details to Box No. G198.

LOW DEFINITION TELEVISION REVIVAL. Interested in Baird-type TV? Write to: LDTV, 1 Burnwood Drive, Wollaton, Nottingham.

CHROMASONIC ELECTRONICS. New list 10p. post free. Data Dept., 56 Fortis Green Road, London, N10 3HN.

EXPERIMENTERS AND MODEL MAKERS! Hundreds of unusual items cheap. 1973 catalogue 5p. Grimsby Electronics, 64 Tennyson Road, Cleethorpes, Lincs., DN35 7LF. (Mail order only).

BUILD THE MULLARD C.C. TV CAMERA. Complete kits now available from Crofton Electronics. Send large s.a.e. for details to: 15-17 Cambridge Road, Kingston-Upon-Thames, Surrey. Reply by post. No callers please.

WANTED: Copy of the original RTTY Manual produced by the British Amateur Radio Teleprinter Group. Box No. G206.

COMPUTER BOARDS - CHEAP! 10 without transistors £1.00, 10 with transistors (inc. power trans. and h/sinks) £1.50, p/p 20p. AMPEX boards - inc. min. 4 trimpts - 4 for £1.00; with 2 Motorola power transistors 4 for £1.50, p/p 20p. Belling-Lee 25x plug and sockets, 30p each, p/p 5p, 4 for £1.00, p/p 15p. Continental 56-way edge connectors, 10 for £1.00, p/p 15p. Multicore cable e.g. x 24 at 15p yard. All items used but excellent condition. Many more items. Enquiries welcome. Tope, 31 Wood Lane, London N.W.9. Telephone: 01-205-5965.

(Continued on page 725)

BENTLEY ACOUSTIC CORPORATION LTD.

All prices inclusive of V.A.T.

The Old Police Station, Gloucester Road, LITTLEHAMPTON Sussex. PHONE 6743

OA2	30	12BE6	30	EL84	21	PD5001	1.44	UL141	54
OB2	30	12J7GT	33	EAF42	48	PEN45	40	UL84	28
SC4G	30	12K5	50	EAF801	50	EL86	38	PEN45DD	44
SV4G	33	12K7GT	33	EL91	23	EL91	23	UV85	33
3Y3GT	30		34	EB91	10	EL95	32	PFL200	50
5Z4G	33	12Q7GT		EB41	48	EL180	75	PL36	46
6J30L2	53			EB81	29	EN180	37	PL81	42
6AQ5	21	19A05	24	EBF30	30	EM81	37	PL82	26
6AT6	18	20P4	89	EBF83	38	EM83	75	PL83	30
6AU6	19	30A5	44	EBF89	26	EM84	31	PL84	28
6AV6	28	30C15	55	EC92	34	EM87	49	PL504	60
6BA6	19	30C17	74	ECC331	50	EY51	35	PL508	90
6BE6	20	30C18	69	ECC35	95	EY81	35	PY33/2	50
6BH6	43	30P5	61	ECC81	16	EY83	54	PY81	24
6B16	39	30FL1	58	ECC82	19	EY87/6	27	PY81	23
6BR7	79	30FL2	60	ECC83	21	EY88	40	PY83	26
6BW6	72	30FL14	66	ECC84	28	EZ40	40	PY88	31
6BW7	50	30L15	55	ECC85	32	EZ80	19	PY800	31
6BZ6	31	30L17	65	ECC88	35	EZ81	20	PY801	31
6C4	28	30P12	69	ECC89	27	GY501	75	QVQ03	31
6CJ5	30	30P19	65	ECC82	25	GZ34	47	U	1.20
6E5	55	30PL1	57	ECF86	64	HVR2	53	R19	28
6F1	59	30PL3	75	ECH35	50	KTW61	63	U25	65
6F6G	35	30PL14	75	ECH42	57	PC88	44	U501	76
6F18	45	10PL15	87	ECH81	25	KTW63	50	U191	65
6F23	65	15A3	48	ECH83	38	KT66	80	U251	62
6F28	60	35L6GT	42	ECL84	34	PC86	44	U301	40
6G7G	15	35W4	23	ECL86	28	PC88	44	U501	76
6K7G	12	35Z4	24	ECL82	28	PC95	53	UABC80	0C24
6K8G	33	35Z5	30	ECL83	52	PC97	36	0C25	42
6L6GT	50	50C5	32	ECL84	54	PC900	29	UBC41	45
6M7G	35	30L6GT	45	ECL85	54	PC854	24	UBC81	40
6O7GT	43	90C1	59	ECL86	33	PCC88	39	UBF80	33
6Q7(M)	43	DAF91	20	E222	63	PCC89	42	UBF89	33
6V6GT	27	DAF96	33	F41	58	PCC189	46	UC92	35
6X4	20	DF91	14	FR80	21	PCF80	28	UC81	29
7Y4	60	DF96	14	FR83	54	PCF82	30	UC85	33
9D7	78	DK91	26	FR85	25	PCF84	40	UCF80	31
10F1	75	DK92	49	FR86	27	PCF86	44	UCH42	57
10F18	35	DK96	43	FR89	22	PCF801	28	UC84	11
12A6	63	DL92	23	F91	17	PCF802	37	UCL82	30
12AC6	40	DL96	35	EP92	28	PCF806	55	UCL83	54
12AD6	40	DY87/6	22	EP183	25	DF182	29	UF41	50
12AE6	48	DY802	29	EP184	27	PCL83	54	UF80	35
12AT6	23	EBKCC	60	EH90	34	PCL84	32	UF85	34
12AU6	21	E180F	90	EL34	48	PCL85	37	UF86	63
12AV6	28	EA50	27	EL41	53	PCL86	36	UF89	27
12BA6	30	EABC80							

All goods are unused and boxed, and subject to the standard 90-day guarantee. Terms of business: Cash or cheque with order only. No C.O.D. orders accepted. Despatch charge 9p per order up to three items, each additional item 3p extra. Orders over £5 despatched free. All orders despatched same day by first class mail. Terms of business available on request. Any parcel insured against damage in transit for only 3p extra per order. Business hours 9 a.m.-5.30 p.m., Mon.-Fri. Closed Sats. Please enclose S.A.E. with all enquiries.

BI-PRE-PAK

5W AMP for only £1.98

(inclusive of P.&P. and VAT)

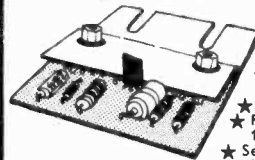

- ★ Nominal 12-14V
- ★ Power output into 3 ohms = 5W
8 ohms = 2W; 15 ohms = 1W
- ★ Distortion typically 0.5%
- ★ Frequency response at 3dB points
10Hz to 30KHz
- ★ Sensitivity (with/without tone control)
130mV
- ★ Quiescent current 100mA.
- ★ Full power 3 ohms (650mA).

This matchbox sized amplifier will run satisfactorily from a 12V car battery. Can also be used for portable voice reinforcement such as public functions where mains supply is not accessible. A small mains unit is available.

Two amplifiers are ideal for Stereo. Complete connection details and treble, base, volume and balance control circuit diagrams are supplied with each unit.

Discounts are available for quantity orders.

Cheapest in the U.K. Built and tested.

I enclose £..... for amplifiers.

Name

Address

BI-PRE-PAK

DEPT C, 222/224 WEST RD,
WEST CLIFF-ON-SEA, ESSEX
SS8 9DF. Tel. Southend (0702)
46344

Co. Regn. No. 820919

PRECISION

POLYCARBONATE CAPACITORS

Close tolerance professional capacitors by well-known manufacturer. Excellent stability and extremely low leakage. All 63V D.C.

0.47 μ F: $\pm 5\%$ 30p; $\pm 2\%$ 40p; $\pm 1\%$ 50p
 1.0 μ F: $\pm 5\%$ 40p; $\pm 2\%$ 50p; $\pm 1\%$ 60p
 2.2 μ F: $\pm 5\%$ 50p; $\pm 2\%$ 60p; $\pm 1\%$ 75p
 4.7 μ F: $\pm 5\%$ 70p; $\pm 2\%$ 90p; $\pm 1\%$ 115p
 6.8 μ F: $\pm 5\%$ 95p; $\pm 2\%$ 115p; $\pm 1\%$ 150p
 10.0 μ F: $\pm 5\%$ 110p; $\pm 2\%$ 140p; $\pm 1\%$ 180p
 15.0 μ F: $\pm 5\%$ 160p; $\pm 2\%$ 210p; $\pm 1\%$ 270p

NEW! — TANTALUM BEAD CAPACITORS

Values available .1, .22, .47, 1.0, 2.2, 4.7, 6.8 μ F at 35V, 10 μ F 25V, 15 μ F 20V, 22 μ F 15V, 33 μ F 10V, 47 μ F 6V, 100 μ F 3V. All at 9p each; 6 for 50p; 14 for £1.00. Special pack, 6 off each value (78 capacitors) for £5.00.

TRANSISTORS: BC107; BC108; BC109 all at 9p each. 6 for 50p; 14 for £1.00; AF178 at 42p each or 3 for £1.00. All brand new and marked.

POPULAR DIODES: IN914 - 7p each; 8 for 50p; 18 for £1.00 IN916 - 9p each; 6 for 50p; 14 for £1.00. IS44 - 5p each; 11 for 50p; 24 for £1.00. All brand new and marked.

400mW ZENER DIODES: Values available 4.7, 5.6, 6.8, 7.5, 8.2, 9.1, 10, 11, 12, 13.5, 15 volts. All new and marked. All at 10p each; 6 for 50p; 14 for £1.00. SPECIAL 6 off each voltage (66 zeners) £4.50
SILICON PLASTIC RECTIFIERS 1.5 amp wired-ended D027. 100 PIV at 8p each or 4 for 30p; 400 PIV at 9p each or 4 for 34p; 800 PIV at 14p each or 4 for 50p.

RESISTORS: Carbon film 5% $\frac{1}{4}$ w at 40°C, $\frac{1}{4}$ w at 70°C. Range 2.2 Ω -2.2M Ω . E12 series i.e. 10, 12, 15, 18, 22, 27, 33, 39, 47, 56, 68, 82, and their decades. All at 1p each. 8p for 10; 70p for 100 of any one value. Special pack 10 off each value 2.2 Ω to 2.2M Ω (730 resistors) for £5.00.

440V A.C. CAPACITORS: 0.1 μ F: Size 1 $\frac{1}{8}$ " x $\frac{1}{2}$ ", 25p each
 0.25 μ F: Size 1 $\frac{3}{8}$ " x $\frac{3}{8}$ ", 30p each 0.5 μ F: Size 1 $\frac{3}{8}$ " x $\frac{3}{4}$ ", 35p each
 1.0 μ F: Size 2" x $\frac{3}{4}$ ", 45p each 2.0 μ F: Size 2" x 1", 75p each
 Suitable for use on C.D. ignition, 250V A.C. motors, etc.

5p p. & p. on all orders below £5. Please add 10% V.A.T.

MARCO TRADING (Formerly V. ATTWOOD)
 Dept. R6 The Maltings, Station Road, Wem, Salop

THE 'PLUS' CATALOGUE

+ Technical data + Countless bargains + Discounts



+
 25p
REFUND VOUCHER

The Electrovalue Catalogue now costs 25p (post free, surface mail) and is well worth it for its technical information. But we include with it a 25p refund voucher for spending on orders for £5 or more. You will find this catalogue a great money saver in every way.

- 96 Pages. (4th printing)
- Transistors, with technical specs.
- I.Cs with working diagrams
- Resistors, capacitors, components
- Diagrams, tables, information
- GENUINE DISCOUNTS

ELECTROVALUE LTD. Dept. R.C.6.
 28 St. Judes Rd., Englefield Green, Egham, TW20 0HB
 9-6 daily: 1.0 p.m. Sat. Telephone Egham 3603

NEW STYLE SELF-BINDER

for "Radio & Electronics Constructor"

The "CORDEX" Patent Self-Binding Case will keep your issues in mint condition. Copies can be inserted or removed with the greatest of ease. Rich maroon finish, gold lettering on spine.

Specially constructed Binding Cords are made from Super Linen of great strength, very hard twisted and twice doubled. They are attached to strong RUSTLESS Springs under tension, and the method adopted ensures PERMANENT RESILIENCE of the Cords. Any slack that may develop is immediately compensated for and the Cords will always remain taut and strong. It is impossible to overstretch the springs, as a safety check device is fitted to each.

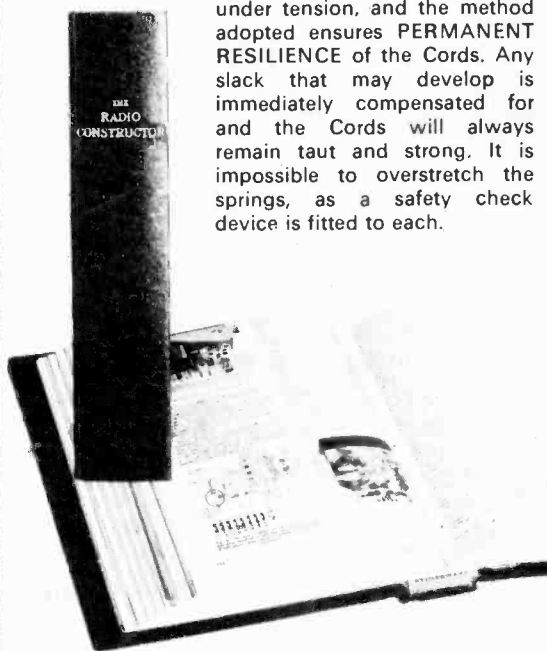

PRICE **83p** P. & P. 14p
 including V.A.T.

Available only from:—

Data Publications Ltd.
 57 Maida Vale London W9 1SN

SMALL ADVERTISEMENTS

(Continued from page 723)

FOR SALE: VHF KIT, 80 - 180 MHz. Receiver, tuner, converter. World wide sales. Incomparable. £4.00 or s.a.e. for literature. Johnsons (Radio C), Worcester WR1 2DT.

5 N-CHANNEL FETS TYPE 3819E for £1.00. Full spec. devices complete with circuit details for building voltmeter, timer, ohmmeter, etc., or send 10p for full list of FETS and other top quality transistors available at bargain prices. Redhawk Sales Ltd., 45 Station Road, Gerrards Cross, Bucks. Mail order only.

MAGNIFIERS: Ideal for the inspection of printed circuit boards, etc., S.A.E. for list to: Revor Optical & Technical, 36 Baker Street, London W1M 1DG.

FOR SALE: 50 n.p.n., unmarked, untested transistors, like BC107/8/9, 50p. Monofilament unsheathed light guide, 10p per metre. J. Fulton, Derrynaseer, Dromore, Co. Tyrone, Ireland.

FOR SALE: Avo electronic testmeter and r.f. signal generator. S.A.E. for details. Box. No. G212.

COMPONENTS GALORE. Pack of 500 mixed components, manufacturers' surplus plus once used. Pack includes resistors, capacitors, transistors, diodes, I.C., pots, coils, etc. Tremendous value. Send £1 plus 10p p. & p. Caledonian Components, Strathmore Road, Thornton, Fife.

SHORT WAVE MAGAZINE, now in its 36th year and published monthly, covers the whole field of Radio Amateur transmission and reception including regular news features (DX, VHF, Clubs and SWL) and the design, construction and operation of Amateur Radio equipment of every type. Cover price 25p at newsagents. Specimen copy 30p post free, first class. Annual subscription £3.00 (or £2.75 second class posting) year of 12 issues. Circulation Dept. (R), Short Wave Magazine Ltd., 55 Victoria Street, London, SW1H-0HF. Telephone: 01-222-5341/2.

CONVERT ANY TV SET into an oscilloscope. Complete instructions. Easy step by step. Box No. G213.

WHY NOT TRY YOUR HAND AT TV? Ex-rental and untried. 19" 625 with u.h.f. tuner, £4.50. 23" 625 with u.h.f. tuner, £6.50. 19" 2 channel sets, £1.50. New mains transformers in 240 volts a.c. output to 6 volts, 60p. All sets complete. Callers only. 103 Goldhawk Road, Shepherd's Bush, London W.12. Telephone: 01-743 6996.

THE BRITISH AMATEUR ELECTRONICS CLUB. A club for all who are interested in electronics as a hobby. Quarterly Newsletter sent free to members. Subscription 50p per year. Details from Hon. Secretary. J. G. Margetts. 17 St. Francis Close. Abergavenny. Mon.

FOR SALE: Transistor amplifier 80p, Vol./tone control panel 75p, 405 i.f. amp. panel 75p, wavechange & osc. panel 75p, LW-MW rod aerial 25p. All the above with circuit £3.00. Skeleton presets, slider or rotary, 200k & 2 Meg, 10 for 25p. Please include p. & p. R. Archer, 9 Pine Grove, Maidstone, Kent.

JOIN THE INTERNATIONAL S.W. LEAGUE. Free services to members including Q.S.L. Bureau, Amateur and Broadcast Translation, Technical and Identification Dept. - both Broadcast and Fixed Stations, DX Certificates, contests and activities for the SWL and transmitting members. Monthly magazine, *Monitor*, containing articles of general interest to Broadcast and Amateur SWLs, Transmitter Section and League affairs, etc. League supplies such as badges, headed notepaper and envelopes, QSL cards, etc., are available at reasonable cost. Send for League particulars. Membership including monthly magazines, etc., £2.00 per annum. (U.K. and British Commonwealth), overseas 6 Dollars or £2.50. Secretary ISWL, 1 Grove Road, Lydney, Glos., GL15 5JE.

(Continued on page 727)

150/A order 30/6

 <p>MULTIMETER Model 200H 20,000 ohm/volt £5.28</p>	 <p>4 1/2" x 3 1/2" Meter 30uA, 50uA or 100uA £2.86</p>
 <p>MULTIMETER Model C-7081GN Range Doubler 50,000 ohm/volt High Sensitivity Meter £12.37</p>	 <p>CARDIOID DYNAMIC MICROPHONE Model UD-130 Frequency response 50-15,000 cps. Dual Impedance 50K & 600 ohms £4.95</p>
 <p>Small DYNAMIC MICROPHONE as pictured or similar with remote on/off switch £1.27</p>	
<p>Large S.A.E. for List No. 5. Special Prices for quantity quoted on request. Add 10p for P&P on orders under £5.</p> <p>M. DZIUBAS 158 Bradshawgate, Bolton, BL2 1BA, Lancs. All above prices include 10% V.A.T. All items advertised in previous numbers of this magazine still available.</p>	

FREE TO AMBITIOUS ENGINEERS

THE LATEST EDITION OF NEW OPPORTUNITIES

SEND FOR YOUR FREE COPY TO-DAY

NEW OPPORTUNITIES is a highly informative 76 page guide to the best paid engineering posts. It tells you how you can quickly prepare at home for a recognised engineering qualification and outlines a wonderful range of modern home study courses in all branches of Engineering. This unique book also gives full details of the Practical Radio & Electronics courses administered by our Specialist Electronics Training Division - explains the benefits of our free Appointments and Advisory service and shows you how to qualify for five years promotion in one year.

PRACTICAL EQUIPMENT INCLUDING TOOLS

The specialist Electronics Division of B.I.E.T. NOW offers you a real laboratory training at home with all the practical equipment you need, plus basic practice and theoretical Courses for beginners in Radio, TV, Electronics, etc.

CUT OUT THIS COUPON

Tick or state subject of interest. Post to address below.

AMSE (Elec) City & Guilds Certificate RTEB Certificate
 Radio Amateurs' Exam DMG Certificate Colour TV
 Electronic Engineering Computer Electronics Radio and TV Servicing Practical Electronics Practical TV and Radio

BRITISH INSTITUTE OF ENGINEERING TECHNOLOGY

Dept. (BRE 18), Aldermaston Court, Reading RG7 4PF
Accredited by the Council for the Accreditation of Correspondence Colleges

QC **BRE 18**

NAME
(BLOCK CAPITALS PLEASE)

ADDRESS.....

OTHER SUBJECTS..... AGE.....

RSGB BOOKS FOR YOU

A GUIDE TO AMATEUR RADIO

by Pat Hawker, G3VA

Extensively revised, this new (15th) edition is an indispensable aid to all who want to know more about amateur radio. Specially designed to assist the newcomer to the hobby.

96 pages

90p post paid.

AMATEUR RADIO TECHNIQUES

by Pat Hawker, G3VA

Fourth edition

Aimed at extending the readers' awareness of new devices and techniques. Provides a source book for many useful circuits and aeriels. An *ideas* book rather than a constructional manual, but an ideas book that will prove its value time and time again.

256 pages

£1.80 post paid.

RADIO COMMUNICATION HANDBOOK

832 pages of everything in the science of radio communication. The Handbook's U.K. origin ensures easy availability of components. Complete coverage of the technical and constructional fields. A superb hard-bound volume.

£4.10 post paid.

These are three of a complete range of technical publications, log books and maps, all obtainable from:

RADIO SOCIETY OF GREAT BRITAIN
35 Doughty Street, London, WC1N 2AE

'YOUR CASE' NOW SOLVED

BLACK P.V.C. BOXES AVAILABLE



IDEAL FOR ELECTRONIC APPARATUS AND SPECIAL RIG ENCLOSURES

- ★ ROBUST MOULDING
- ★ ALL INSULATED
- ★ EASY TO CUT AND DRILL
- ★ SELF FINISH
- ★ NON-RUSTING
- ★ SELF EXTINGUISHING

Length	Width	Depth	Price each	P. & P. each
4 in.	4 in.	1½ in.	38p	13p
4 in.	4 in.	2 in.	41p	14p
6 in.	3 in.	1½ in.	38p	14p
6 in.	4 in.	2 in.	52p	14p

ALLOW 21 DAYS FOR DELIVERY
ORDERS OVER £8 P. & P. FREE
QUOTATIONS GIVEN FOR LARGE QUANTITIES

ADAPTABOX, DEPT. REC
26 WELBY GARDENS, GRANTHAM
LINCS. NG31 8BN

PLAIN-BACKED NEW STYLE SELF-BINDERS

for your other magazines

(max. format 7½" x 9½")



The "CORDEX" Patent Self-Binding Case will keep your copies in mint condition. Issues can be inserted or removed with the greatest of ease. Specially constructed Binding cords are made from Super Linen of great strength, very hard twisted and twice doubled. They are attached to strong RUSTLESS Springs under tension, and the method adopted ensures PERMANENT RESILIENCE of the Cords. Any slack that may develop is immediately compensated for, and the Cords will always remain taut and strong. It is impossible to over-stretch the springs, as a safety check device is fitted to each.

COLOURS: MAROON OR GREEN

(If choice not stated, colour available will be sent)

77p P. & P. 14p
including V.A.T.

Available only from:—

Data Publications Ltd.
57 Maida Vale London W9 1SN

SMALL ADVERTISEMENTS

(Continued from page 725)

FIBRE GLASS CIRCUIT BOARD. $\frac{1}{16}$ " single sided, $1\frac{1}{2}$ per sq.inch; double sided, $2\frac{1}{2}$ per sq. inch. F. Freemantle, Dept. RC100, 18 Pennine Road, Millbrook, Southampton, Hants.

SMALL TANNOY SPEAKER WANTED, ex-Admiralty pattern would do. Leeves, West Stone, Kingsnympton, Umberleigh, N. Devon.

4-DIGIT COUNTERS, 500 Ω , 25p. 100 $\frac{1}{4}$ - $\frac{1}{2}$ W resistors, 50p. J. Fulton, Derrynaseer, Dromore, Co. Tyrone, Ireland.

FIBRE OPTIC LIGHT GUIDE is used almost like wire to convey light. Applications include:- proximity detectors, encoders, multiple illumination, display panels and decorative devices. Optikit 102 Monofibre Evaluation Pack £1.21, or send s.a.e. (9" x 6") for leaflet plus samples. Fibre Optic Suppliers, P.O. Box 702, London W10 6SL.

FREQUENCY LIST TRANSFERS. We have a limited supply of sheets of Dial Frequency Transfers in black. Short Wave frequencies 1.8Mc/s to 32Mc/s and 144Mc/s and 146Mc/s. Includes amateur band marker frequencies at 100kc/s points and other short wave frequencies from 2 to 32Mc/s at every 500kc/s points. Each frequency is repeated. Two sheets for 5p. five sheets for 10p. postage 3p. Data Publications Ltd., 57 Maida Vale. London W9 1SN.

WANTED: S/Sheet, circuit, for Perdio 8" mains batt/portable TV. S. No. TR75865. J. Woosnam, Leaust, Mochdre, Nr. Newtown, Montg.

ESSEX GARDENERS. Buy your bedding and rock plants, shrubs, etc., also cacti from May's Nurseries, 608 Rayleigh Road, Hutton, Brentwood, Essex. Callers only. Monday to Saturday.

WORLD DX CLUB covers all aspects of SWLing on Amateur and Broadcast Bands through its monthly bulletin "Contact". Membership costs £1.38 a year. Enquiries to Secretary, WDXC, 11 Wesley Grove, Portsmouth, Hants., PO3 5ER.

"MEDIUM WAVE NEWS" Monthly during Dx season - Details from: K. Brownless, 7 The Avenue, Clifton, York.

SEQUENTIAL TIMING MODULES, 24V d.c. £4.50. 10 East View Fields, Plumpton Green, Sussex, BN7 3EE.

DX - 70 countries logged in a few hours with **RECEIVER MODULE RM-A**, a small circuit-board requiring only connections to tuned circuits and controls (not included) to make a superhet for headphone reception of AM/CW/SSB up to 30MHz. Power 9-12V. £7.85. S.A.E. for details. P. R. Golledge, Glen Tor, Torrington, Devon.

PERSONAL

JANE SCOTT FOR GENUINE FRIENDS. Introductions to opposite sex with sincerity and thoughtfulness. Details free. 3p stamp to: Jane Scott, 50/CON Maddox Street, London W1R 0LY.

HOLIDAY ACCOMMODATION. Burwood Lodge Hotel. Dawlish Road. Teignmouth. South Devon. Especially suitable for parents with young children. Facing south. on the cliffs. direct access by private path to the sea. Mothers' kitchen. automatic washing machines. baby listening service. Licensed lounge. Ample free parking.

JUNE 1973

ESSENTIAL BOOKS

HOW TO MAKE WALKIE-TALKIES FOR
LICENSED OPERATION

Only 40p Post & Packing 10p.

The **Government Surplus Wireless Equipment Handbook.** Gives circuits, data and illustrations plus valuable information for British/USA receivers, transmitters, trans/receivers. With modifications to sets and test equipment. Latest impression £3.25 including postage. **Directory of Government Surplus Wireless Equipment Dealers.** Gives details of surplus wireless equipment stores and dealers including addresses, plus equipment and spares that they are likely to have available. A valuable book only 40p. P. & P. 10p. Allow 28 days for delivery as directory is being brought up to date. **Cosmic Radio Waves.** Start a new hobby - Radio Astronomy. This big book of 444 pages is an ideal handbook for the beginner and established enthusiast. Numerous photographs and illustrations. Published by Oxford University Press. Price £2.50. P. & P. 25p. **Problems in Electronics with Solutions.** A must for the student, technician and electronics engineer. Contains 349 problems, answers and how they were arrived at. Includes all aspects of electronics, amplifiers, power supplies, computers, filters, transmission lines, waveguides, semi-conductors etc. 307 pages. Only 90p. P. & P. 10p. **The Scattering and Diffraction of Waves.** A goldmine of information for the experimenter, amateur and scientist. Profusely illustrated. Published by Oxford University Press. Price £1.60. post free. **Handbook of Satellites and Space Vehicles.** A comprehensive working handbook that provides important data both tabular and graphical enabling space scientists, technicians and engineers to acquire a greater working knowledge of satellite and space vehicle design, launching, orbiting etc. Includes a detailed coverage of **Communications in Space.** An imposing book of 457 pages. Published at £8.20 but available at the trade price of £6.50 post free.

DEPT. R.C. GERALD MYERS.
18, SHAFESBURY STREET, LEEDS LS12 3BT

Personal callers welcome

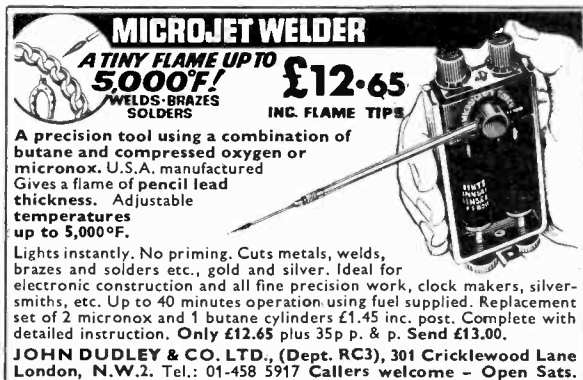

MICROJET WELDER
ATINY FLAME UP TO 5000°F!
WELDS·BRAZES
SOLDERS
INC. FLAME TIPS
£12.65

A precision tool using a combination of butane and compressed oxygen or micronox. U.S.A. manufactured. Gives a flame of pencil lead thickness. Adjustable temperatures up to 5,000°F.

Lights instantly. No priming. Cuts metals, welds, brazes and solders etc., gold and silver. Ideal for electronic construction and all fine precision work, clock makers, silver-smiths, etc. Up to 40 minutes operation using fuel supplied. Replacement set of 2 micronox and 1 butane cylinders £1.45 inc. post. Complete with detailed instruction. Only £12.65 plus 35p p. & p. Send £13.00.

JOHN DUDLEY & CO. LTD., (Dept. RC3), 301 Cricklewood Lane London, N.W.2. Tel.: 01-458 5917 Callers welcome - Open Sats.

MORSE MADE EASY!!!

FACT NOT FICTION. If you start **RIGHT** you will be reading amateur and commercial Morse within a month. (Normal progress to be expected.) Using scientifically prepared 3-speed records you automatically learn to recognise the code **RHYTHM** without translating. You can't help it, it's as easy as learning a tune. 18-W.P.M. in 4 weeks guaranteed. Beginner's Section only £3.30. Complete course £4.50 (Overseas £1 extra). Details only, 4p stamp. 01-660 2896

G3HSC/Box 38, 45 GREEN LANE, PURLEY, SURREY.

SYNTHESISER MODULES

Voltage-controlled modules for synthesiser construction and other musical **MIRACLES!** Catalogue 15p. D.E.W. Ltd., 25- Ringwood Road, Ferndown, Dorset.

RADIO MODELLER



ELECTRONIC BOOKS

● MODEL RADIO CONTROL

Detailing both Theory and Practice, this book, by leading authority Paul Newell, will become the standard reference work. A brief historical survey leads up to a detailed description of proportional systems, with over 100 illustrations, including theoretical circuits and p.c. layouts for an advanced digital system.

134 pages. Price £2.25 U.K. Postage 13p

● SINGLET SET

The Singlet Transmitter, Superhet and Super-regen receivers, are now all three available in one book. Complete construction details with full size p.c. layout, components list etc. Ideal introduction to the hobby for the home constructor. 20 pages.

Price 30p. U.K. Postage 3p

● LOW COST PROPORTIONAL

Modellers who want to save money buy this volume when converting single channel equipment to simple proportional. They find a wealth of really up to date information in the clear descriptions, full size practical and working drawings, plus over a dozen circuit modules for pulse proportional units.

118 pages.

Price £1.05 U.K. Postage 11p



ON SALE NOW at all leading shops or direct from:-

RADIO MODELLER, BOOK SALES, 64 Wellington Road, Hampton Hill, Middx.

DATA BOOK SERIES

- DB5 TV FAULT FINDING
124 pages. Price 50p, postage 6p.
- DB6 RADIO AMATEUR OPERATOR'S HANDBOOK
80 pages. Price 45p, postage 6p.
- DB16 RADIO CONTROL FOR MODELS
192 pages. Price 75p, postage 8p.
- DB17 UNDERSTANDING TELEVISION
512 pages. Price £2.10, postage 25p.
- DB18 AUDIO AMPLIFIERS
128 pages. Price 53p, postage 6p.
- DB19 SIMPLE SHORT WAVE RECEIVERS
140 pages. Price 80p, postage 6p.

I enclose Postal Order/Cheque for..... in payment for.....

NAME

ADDRESS

(BLOCK LETTERS PLEASE)

Postal Orders should be crossed and made payable to Data Publications Ltd.

Overseas customers please pay by International Money Order.

All publications are obtainable from your local bookseller.

Data Publications Ltd., 57 Maida Vale, London W9 1SN

PLEASE MENTION THIS MAGAZINE WHEN WRITING TO ADVERTISERS

RESONANT FREQUENCIES III

The Table gives calculated resonant frequencies, in kHz, for tuned circuits having inductances from 250 to 3,000 μ H and capacitances of 5pF, 20pF, 80pF and 320pF. Thus, 600 μ H and 20pF are resonant at 1,450kHz.

Inductance (μ H)	5pF	20pF	80pF	320pF	Inductance (μ H)	5pF	20pF	80pF	320pF
250	4,500	2,250	1,130	562	750	2,600	1,300	650	325
275	4,290	2,150	1,070	536	800	2,520	1,260	631	315
300	4,110	2,050	1,030	514	850	2,440	1,220	610	305
325	3,940	1,970	984	482	900	2,370	1,190	593	297
350	3,810	1,900	952	476	950	2,310	1,150	577	289
375	3,680	1,840	920	460	1,000	2,250	1,120	562	281
400	3,550	1,770	889	444	1,100	2,140	1,072	536	268
425	3,450	1,720	861	431	1,200	2,050	1,030	501	256
450	3,360	1,680	840	420	1,300	1,970	985	492	246
475	3,270	1,630	817	409	1,400	1,900	952	476	238
500	3,180	1,590	795	397	1,500	1,840	920	460	230
550	3,040	1,520	760	380	1,750	1,700	850	425	212
600	2,910	1,450	727	364	2,000	1,590	795	397	199
650	2,790	1,390	697	349	2,500	1,420	710	355	177
700	2,690	1,340	672	336	3,000	1,300	650	325	162

Henry's

YOUR COMPLETE AUDIO-ELECTRONIC STORES

More of everything at the right price. All your electronic requirements within 200 yards - call and see for yourself.

BUILD THE TEXAN

20+20 WATT INTEGRATED I.C. STEREO AMPLIFIER

FREE TEAK CABINET with complete kits
FEATURES New slim design with 6 - IC's, IC sockets, 10 silicon transistors, 4 rectifiers, 2 zeners. Special Gardeners low field slim line transformer. Fibre glass PC panel. Complete chassis work **HIGH QUALITY AND STABILITY ARE PREDOMINANT FEATURES** - DEVELOPED BY TEXAS ENGINEERS FOR PERFORMANCE, RELIABILITY AND EASE OF CONSTRUCTION. **FACILITIES** On/off switch indicator, headphone socket, separate treble, bass, volume and balance controls, scratch and rumble filters, mono/stereo switch, input selector, Mag P.U. Radio Tuner. Aux Can be altered for Mic, Tape, Tape head etc. (Parts list Ref. 20 on request.)
 Constructional details Ref. No. 21 30p
 Designed approved kits distributed by Henry's Radio Ltd.

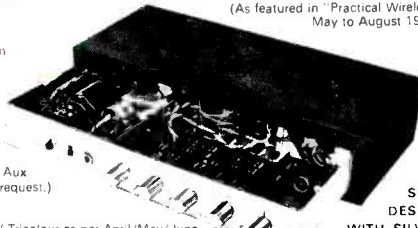

(As featured in "Practical Wireless" May to August 1972)

SLIM DESIGN WITH SILVER TRIM

Overall chassis size 14 1/2" x 6" x 2" high

Complete with **FREE TEAK CABINET P & P 45p**
 PW Tricolour as per April/May/June 1973 Parts List on request (52A)

SPECIAL KIT PRICE £28.50

LOW COST HI-FI SPEAKERS

E.M.I. Size 13 1/2" x 8 1/2" Large Ceramic Magnet.
TYPE 150 6 watt, 3, 8 or 15 ohms. **£2.20** Post 22p.
TYPE 150TC Twin cone version. **£2.75** Post 22p.
TYPE 450 10 watt with twin tweeters and crossover, 3, 8 or 15 ohms. **£3.50** Post 25p.
TYPE 350 20 watt with tweeter and crossover, 8 and 15 ohms. **£7.50** Post 28p.
POLISHED CABINETS 150, 150TC, 450 **£4.60** Post 30p
ASSEMBLED IN POLISHED CABINETS (8 ohms) Series 6 (Assembled 150TC) per pair **£16.50** post 70p
 Series 8 (Assembled 450) per pair **£18.95** post 70p



NEW MW/LW TUNER TO BUILD ML-3

Uses Mullard Module. Slow motion tuning. Built in battery. Ferrite aerial. Overall size 7" x 2 1/2" x 3 1/2". **TOTAL COST TO BUILD £4.85**. Post 15p.



"BANDSPREAD" PORTABLE TO BUILD

Printed circuit all-transistor design using Mullard RF/IF Module Medium and Long Wave bands plus Medium Wave Bandspread for extra selectivity. Also slow motion geared tuning, 600mV push-pull output, fibre glass PVC covered cabinet, car aerial socket. Attractive appearance and performance. **TOTAL COST TO BUILD £7.98** p.p. 32p. (Battery 22p.)



HENRY'S CATALOGUE

Fully detailed and illustrated covering every aspect of Electronics - plus data, circuits and information.

10,000 Stock lines at Special Low Prices and Fully Guaranteed.

PRICE 55p Post Paid

(40p FOR CALLERS)

PLUS! FIVE 10p VOUCHERS

Send to this address - Henry's Radio Ltd. (Dept. RC), 3 Albemarle Way, London, E.C.1. - for catalogue by post only. All other mail and callers to "303", see above.

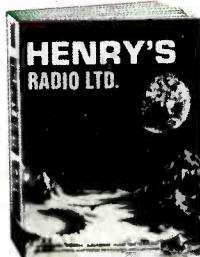

HIGH QUALITY CASSETTES

The best UK low noise tapes but at a special price. 'Living Sound' cassettes meet the highest international standard (IEC 94A). Full guarantee. Post paid. Made by EMI especially for Henry's

	3 for	6 for	10 for
C60	1.10	2.00	3.10
C90	1.47	2.85	4.65
C120	1.80	3.50	5.60

TEST EQUIPMENT

JUST A SELECTION

- SE250B Pocket Pencil Signal Injector **£1.90**
- SE500 Pocket Pencil Signal Tracer **£1.50**
- TH133D Robust 2K/Volt. **£4.55** With case **£4.99**
- TE15 Grid Dip Meter 440 KHz - 280 MHz **£13.45**
- 500 30 K. Volt Multimeter **£9.25** With leather case **£10.50**
- 200H 20K/Volt Multimeter **£4.20** With case **£4.95**
- AF105 50K/Volt Multimeter **£8.50** With case **£9.50**
- U4341 AC/DC Multimeter with transistor tester with steel case **£10.50**
- TE200 RT Generator 120KHz 500MHz **£16.50**
- TE22D Audio Generator 20Hz 200KHz Carr 35p **£17.50**
- C15 3" Pulse Scope 10Hz - 10MHz Carr 50p **£39.00**
- TE65 Valve Voltmeter 28 ranges Carr 40p **£17.50**

ALL NOMBREX MODELS IN STOCK

BUILD THIS VHF FM TUNER

5 TRANSISTORS 300 kc/s BAND-WIDTH. PRINTED CIRCUIT. HIGH FIDELITY REPRODUCTION. MONO AND STEREO. A popular VHF FM Tuner for quality and reception of mono and stereo. There is no doubt about it - VHF FM gives the REAL sound. All parts sold separately. Free Leaflet No. 3 & 7. **TOTAL £6.97** p.p. 20p. Mk 1 Decoder Kit **£5.97**. Built IC Decoder **£6.50** Tuning meter unit **£1.75**. Mains unit for Tuner and/or Decoder PS6/12 **£3.25** Post 20p



PA-DISCO-LIGHTING

- UK's Largest Range - Write phone or call in. Details and demonstrations on request.
- DJ30L 3 Channel sound to light unit 3Kw **£29.50**
 - DJ40L 3 Channel Mic (built in) to light 3 Kw **£38.75**
 - DJ70S 70 watt Disco amp/mixer **£49.75**
 - DISCOAMP 100 watt Disco amp/mixer **£65.85**
 - DJ105S 30 watt Disco amp/mixer Anti-Feedback Quality Mic. **£32.25**
 - DJ500 50 watt P.A. Amp **£11.50**
 - DJ1000 100 watt **£63.00**
 - DJ300 150 watt rms Group Valve Amp **£86.00** Ref. No. 18
- Portable Discos - Details on request ● Credit terms for callers
- FIBRE OPTICS LIGHTING
 - EFFECTS MICS.
 - PROJECTORS
 - SPOTS SPKRS.
 - DIMMERS
 - MIXERS STANDS
 - Everything for PA
 - Disco - Lighting
 - FREE Stock List



SINCLAIR PROJECT 60 MODULES—SAVE POUNDS

- Z30 **£3.57** Z50 **£4.37**
- STEREO 60 **£7.97** PZ5 **£3.97**
- PZ6 **£6.37** PZ8 **£4.77**
- Transformer for PZ8 **£2.95**
- Active Filter Unit **£4.45**
- Stereo FM Tuner **£16.95**
- IC12 **£1.80** O16's **£15** pr.
- Post etc 20p per item.
- PACKAGE DEALS Post 25p.
- 2 x Z30, Stereo 60, PZ5 **£15.95**
- 2 x Z30, Stereo 60, PZ6 **£18.00**
- 2 x Z50, Stereo 60, PZ8 **£20.25**
- Transformer for PZ8 **£2.95**
- PROJECT 60S KIT **£19.95**



Huge range of transistors and semi-conductors in stock. Free brochure. Ref. 35 on request.

ELECTRONIC KITS

Henry's introduce new huge range of audio and electronic kits now in stock, everything supplied, tremendous value. Detailed list Ref. no 14 on request.

I.C. RECEIVER

ZN 414 Radio integrated circuit as featured in *Practical Wireless*, January 1973. Article reprint ref No. 19 10p
 Price **£1.20**

BATTERY TAPE DECK

Garrard 9 volt Tape deck with heads, etc.. As previously advertised. Limited quantity. **£9.50** post 30p.

LEARN A LANGUAGE

Recorded Cassettes with step by step phrase books. French, German, Spanish, Italian. **£1.36** per course. **£5.00** per set of four.

ULTRASONIC TRANSDUCERS

Operate at 40kc/s up to 100 vds. Ideal remote switching and signalling. Complete with data and new I.C. circuits. **PRICE PER PAIR £5.90**. Post 10p.

MARRIOTT TAPE HEADS 4 TRACK MONO or 2 TRACK STEREO

- "17" High Impedance **£2.00**
- "18" Med Impedance **£2.00**
- "36" Med-Low Imp. **£3.50**
- Erase Heads for above **75p**
- "63" 2 track mono - Hi Imp. **£1.75**
- "43" Erase Head for above **75p**

7 SEG & NIXIE TUBES

(Post 15p per 1 to 6)
 XN3, XN13, GN4 0-9 Side view with data **85p**
 GNP 7, GNP 8 0-9 Side view with decimal points and data **95p**
 3015F 7-segment **£2** each. **£7** per 4 with data.
 12 and 24 hour clock circuits for above. Ref. No 31 15p.

MINIATURE AMPLIFIER

5 transistor, 300mW o/p. Fitted volume and sensitivity control 9 volt operated. **£1.75** each P/P 15p.

DISCO SPOTBANK

as illustrated on the front cover of *Practical Wireless*, April '73. **£12.75** p. & p. 35p.

QUALITY SLIDER CONTROLS

60mm stroke singles and ganged. Complete with knobs 5K, 10K, 25K, 100K, 250K, 500K, 1 meg, Log. and Lin. **40p** each. 10K, 25K, 50K, 100K, 250K Log. and Lin. ganged. **60p** each.

HI-FI EQUIPMENT

Warehouse prices with BIG DISCOUNTS plus demonstrations (for callers) and GUARANTEES.

FREE 24 page detailed brochure (Ref. no. 17).

You can see the savings!

VAT ALL PRICES are exclusive of 10% Value Added Tax which must be added to all orders, including carriage/packing. (Note: catalogue is not subject to V.A.T.)

Henry's RADIO LIMITED
 EDGWARE ROAD, W2

404-406 Electronic Components and Equipment 01-402 8381
 354-356 High Fidelity and Tape Equipment 01-402 5854/4736
 309 PA-Disco-Lighting High Power Sound 01-723 6963
 303 Special offers and bargains store
 All mail to 303 Edgware Road, London W2 1BW

Open - 9 am-6 pm
 6 days a week
 (309 closed
 Thursday)
 All stores open
 all day Saturday